

CANDIDATE
NAME

CENTRE
NUMBER

--	--	--	--	--

CANDIDATE
NUMBER

--	--	--	--

MATHEMATICS (SYLLABUS D)

4024/21

Paper 2

May/June 2014

2 hours 30 minutes

Candidates answer on the Question Paper.

Additional Materials: Geometrical instruments
 Electronic calculator

READ THESE INSTRUCTIONS FIRST

Write your Centre number, candidate number and name on all the work you hand in.

Write in dark blue or black pen.

You may use a pencil for any diagrams or graphs.

Do not use staples, paper clips, highlighters, glue or correction fluid.

DO **NOT** WRITE IN ANY BARCODES.

Section A

Answer **all** questions.

Section B

Answer any **four** questions.

If working is needed for any question it must be shown in the space below that question.

Omission of essential working will result in loss of marks.

You are expected to use an electronic calculator to evaluate explicit numerical expressions.

If the degree of accuracy is not specified in the question, and if the answer is not exact, give the answer to three significant figures. Give answers in degrees to one decimal place.

For π , use either your calculator value or 3.142, unless the question requires the answer in terms of π .

The number of marks is given in brackets [] at the end of each question or part question.

The total of the marks for this paper is 100.

This document consists of **23** printed pages and **1** blank page.

Section A [52 marks]Answer **all** questions in this section.

- 1 (a) Express as a single fraction in its simplest form $\frac{x}{(x-4)^2} - \frac{2}{x-4}$.

Answer [2]

- (b) Solve the simultaneous equations.

$$2x - 3y = 14$$

$$6x + 4y = 3$$

Answer $x =$

$y =$ [3]

(c) Solve $x(x - 4) = 6 + x$.

Answer $x = \dots\dots\dots$ or $\dots\dots\dots$ [3]

(d) Simplify $\frac{y^2 - 9}{2y^2 - y - 15}$.

Answer $\dots\dots\dots$ [3]

2 (a) $\mathcal{C} = \{x: x \text{ is an integer and } 5 \leq x \leq 15\}$

$A = \{x : x \text{ is a multiple of } 3\}$

$B = \{x : x \text{ is a factor of } 60\}$

$C = \{x : x \text{ is a prime number}\}$

(i) Find $n(A \cap B \cap C)$.

Answer [1]

(ii) Find $(A \cup B)'$.

Answer [1]

(iii) A number, r , is chosen at random from \mathcal{C} .

Find the probability that $r \in A \cap B$.

Answer [1]

(iv) Given that $D \subset B$ and $D \subset C$, find D .

Answer [1]

- (b) An activity camp offers 3 sports: tennis, cricket and volleyball.
One day, 50 children took part in these sports.

19 children played tennis, 34 children played cricket and 23 children played volleyball.
2 children played all three sports.
5 children played tennis and cricket.
10 children played tennis and volleyball.

By drawing a Venn diagram, or otherwise, find the number of children who played

- (i) tennis and cricket but not volleyball,

Answer [1]

- (ii) cricket and volleyball but not tennis,

Answer [1]

- (iii) cricket only.

Answer [1]

- 3 (a) Zara owns a hairdressing salon.
She buys a pack of 60 bottles of shampoo from a warehouse for \$240.
She plans to sell the bottles of shampoo to her customers for \$5.50 each.

(i) Calculate the percentage profit Zara makes on each bottle she sells for \$5.50 .

Answer [2]

(ii) Zara sells 45 bottles at the full price then sells the rest with a 20% discount.

Calculate the total profit she makes selling all 60 bottles.

Answer \$ [2]

(iii) When the warehouse sells a pack of shampoo for \$240 it makes a profit of 15%.

Calculate the price paid for the pack of shampoo by the warehouse.

Answer \$ [2]

(iv) Zara borrows \$2500 from a bank to make improvements to her salon.
She is charged 4.5% per year simple interest.
She pays the money back after 3 years.

Calculate the **total** amount Zara must pay to the bank.

Answer \$ [2]

- (b) The exchange rate between dollars (\$) and pounds (£) is $\$1 = \text{£}0.64$.
The exchange rate between dollars (\$) and euros (€) is $\$1 = \text{€}0.78$.

- (i) Luke changes \$250 into pounds.

Calculate how many pounds he receives.

Answer £ [1]

- (ii) Complete the statement to show the exchange rate between pounds and euros.

<p>Exchange rate</p> <p>£1 = €</p>
--

[2]

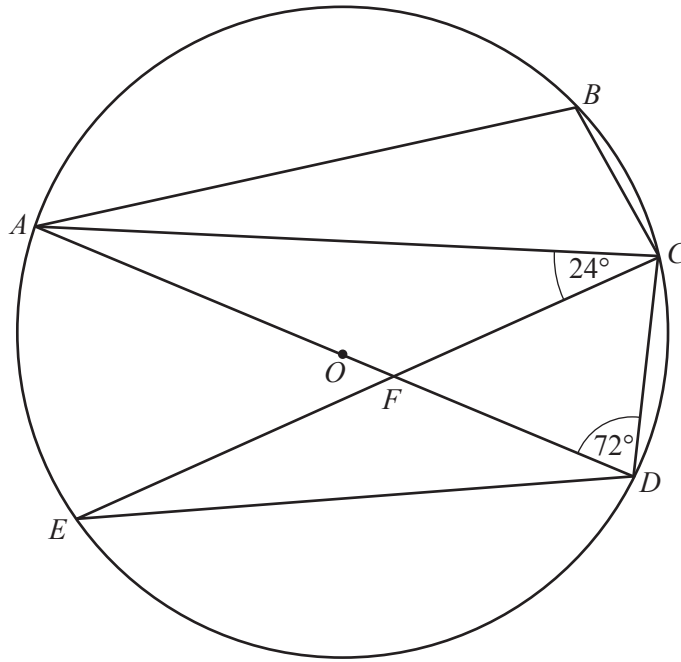

A, B, C, D and E are points on a circle with centre O .
 AD is a diameter of the circle and F is the point of intersection of AD and CE .
 $\widehat{ACE} = 24^\circ$ and $\widehat{ADC} = 72^\circ$.

(a) Find

(i) \widehat{ADE} ,

Answer [1]

(ii) \widehat{CED} ,

Answer [1]

(iii) \widehat{CFD} ,

Answer [1]

(iv) \widehat{ABC} .

Answer [1]

(b) Given that $DC = 4.5$ cm, calculate

(i) the diameter of the circle,

Answer cm [2]

(ii) DE .

Answer cm [2]

- 5 (a) Here is part of a number grid.

A square can be placed anywhere on the grid outlining four numbers.

The numbers in opposite corners of the square are multiplied together and the difference between the products is found.

1	2	3	4	5	6
7	8	9	10	11	12
13	14	15	16	17	18
19	20				

$$9 \times 14 - 8 \times 15 = 126 - 120 = 6$$

- (i) The grid is continued downwards.

If n represents the number of the top left of the square, complete this square with expressions for the other numbers.

n	$n + 1$

[1]

- (ii) Use your answer to **part (a)(i)** to prove that the difference between the products of the opposite corners is **always** 6.

[2]

- (b) Here is part of a different number grid.
 A cross can be placed anywhere on the grid outlining five numbers.
 The numbers in the cross are added together.

1	2	3	4	5	6	7	8	9	10
11	12	13	14	15	16	17	18	19	20
21	22	23	24	25	26	27	28	29	30
31	32	33	34	35	36				
41	42								

- (i) Find and simplify an expression, in terms of n , for the sum of the numbers in the cross below.

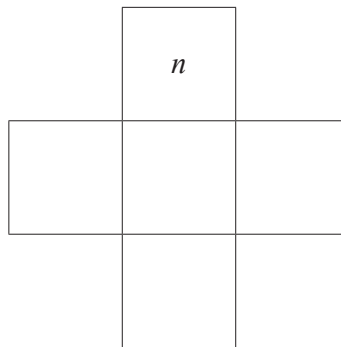

Answer [2]

- (ii) The sum of the numbers in the cross below is 330.

Complete the cross with the correct numbers.

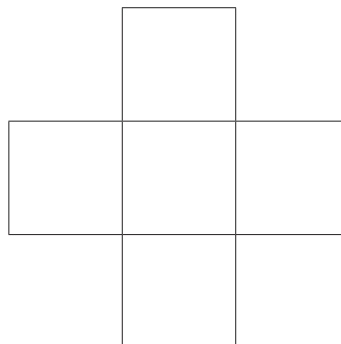

[2]

6 (a) A candle is in the shape of a cylinder of radius 1.6 cm and height 7.5 cm.

(i) Calculate the volume of the candle.

Answer cm³ [2]

(ii) Six of these candles are packed into a box of height 7.5 cm as shown.

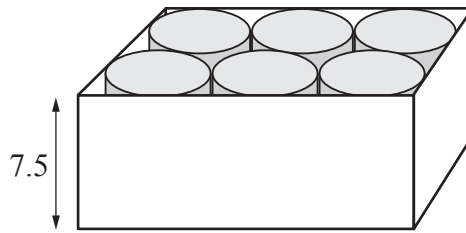

(a) Find the length and width of the box.

Answer length = cm

width = cm [1]

(b) Calculate the volume of empty space in the box.

Answer cm³ [2]

- (b) The length of a rectangular photo is 17.8 cm, correct to the nearest millimetre.
The width of the photo is 12.7 cm, correct to the nearest millimetre.

(i) Calculate the lower bound of the area of the photo.

Answer cm² [2]

- (ii) Kate has a rectangular frame with length 18 cm and width 13 cm, both measured correct to the nearest centimetre.

Will the photo definitely fit into the frame?
Explain your answer.

Answer because

..... [1]

Section B [48 marks]

Answer **four** questions in this section.

Each question in this section carries 12 marks.

- 7 The variables x and y are connected by the equation $y = \frac{x^3}{2} - 3x + 1$.

Some corresponding values of x and y are given in the table below.

x	-3	-2	-1	0	1	2	3
y		3	3.5	1	-1.5	-1	

- (a) Complete the table.

[2]

- (b) On the grid below, plot the points from the table and join them with a smooth curve.

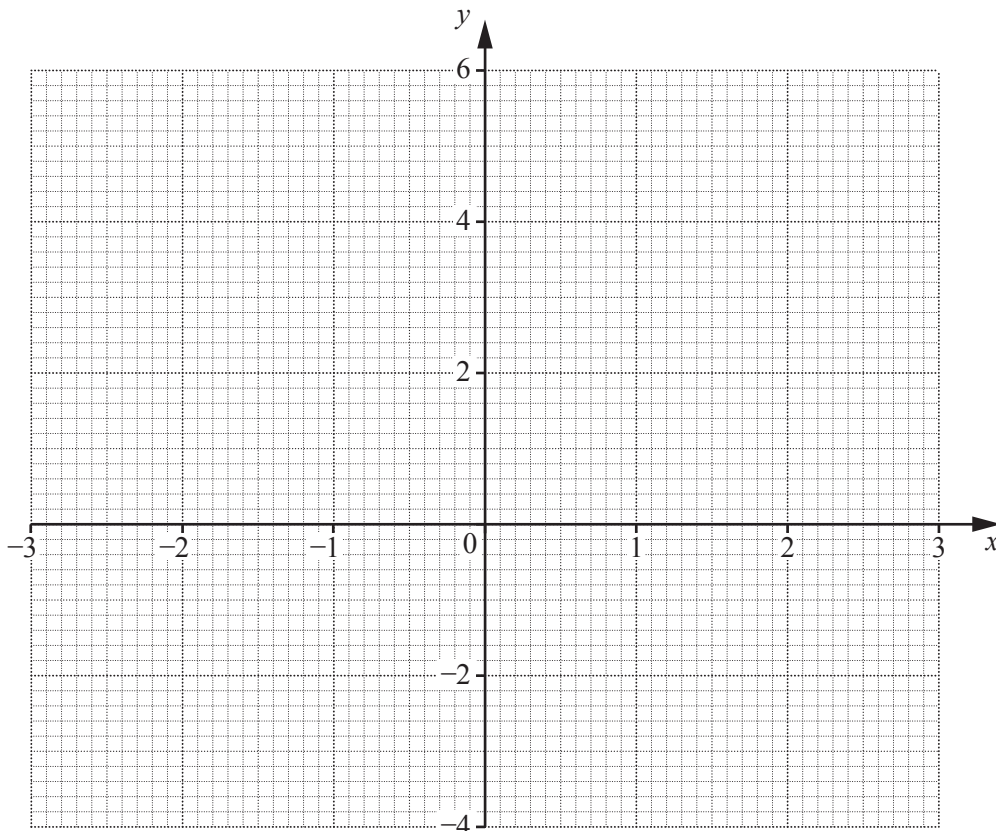

[2]

- (c) Use your graph to solve the equation $\frac{x^3}{2} - 3x + 1 = 0$.

Answer [2]

- (d) By drawing a tangent, find the gradient of the curve at the point $(-2, 3)$.

Answer [2]

- (e) The line AB intersects the curve at point P .
The coordinates of point A are $(0, 5)$.
The coordinates of point B are $(2, -3)$.

- (i) Find the equation of line AB .

Answer [2]

- (ii) The x -coordinate of point P is a solution of the equation $\frac{x^3}{2} + Cx + D = 0$.

Find C and D .

Answer $C =$

$D =$ [2]

- 8 A group of 80 students enters a science quiz.
The table shows the distribution of their scores.

Score (s)	$0 < s \leq 10$	$10 < s \leq 20$	$20 < s \leq 30$	$30 < s \leq 40$	$40 < s \leq 50$	$50 < s \leq 60$
Frequency	4	12	16	23	20	5

- (a) Calculate an estimate of the mean score.

Answer [3]

- (b) (i) Complete the cumulative frequency table for their scores.

Score (s)	$s \leq 10$	$s \leq 20$	$s \leq 30$	$s \leq 40$	$s \leq 50$	$s \leq 60$
Cumulative frequency	4					80

[1]

- (ii) On the grid below,
draw a horizontal s -axis for $0 \leq s \leq 60$ using a scale of 2 cm to represent 10 points
and a vertical axis from 0 to 80 using a scale of 2 cm to represent 20 students.

Draw a smooth cumulative frequency curve to represent this information.

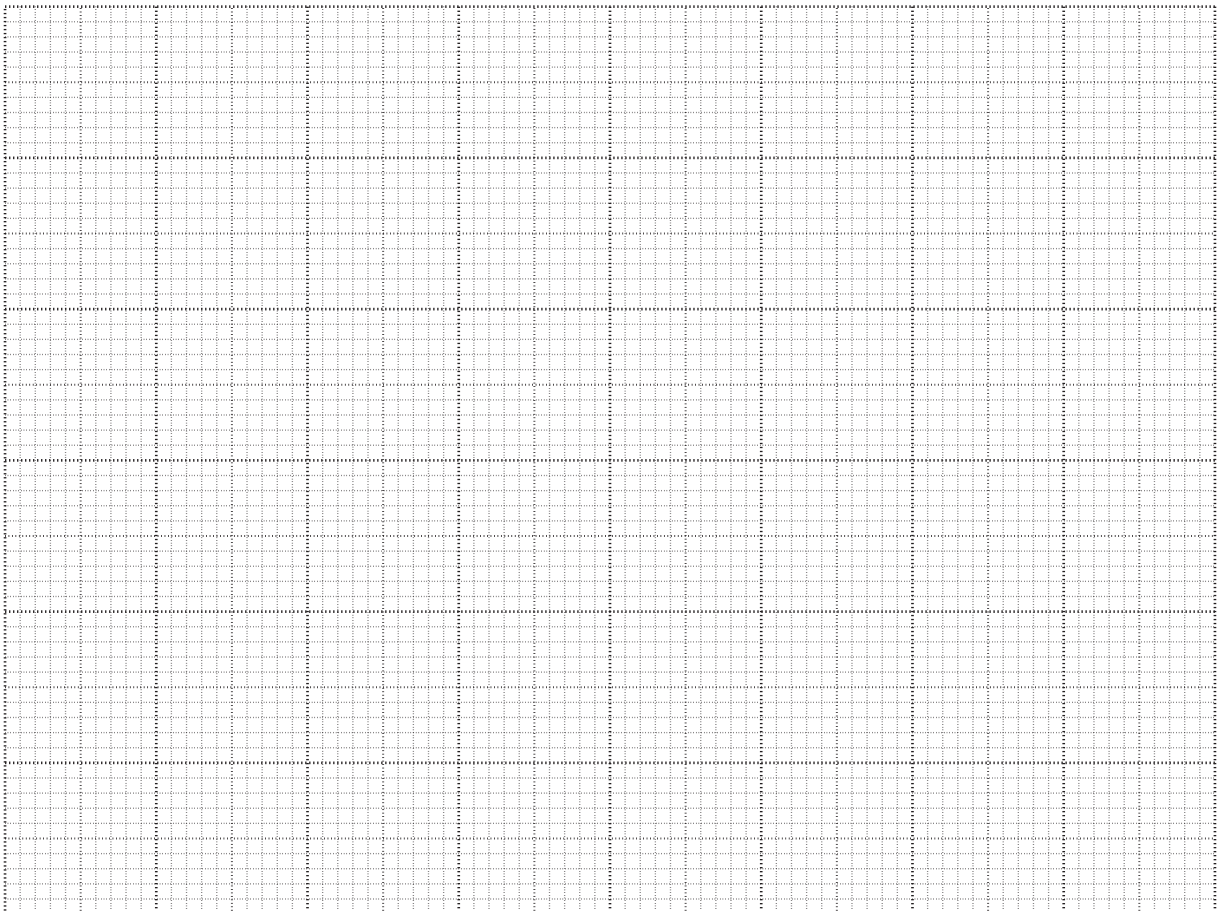

[3]

(iii) Use your graph to estimate

(a) the median score,

Answer [1]

(b) the interquartile range of the scores.

Answer [2]

(c) Students who scored more than 40 points can enter the next round of the quiz.
Two of these students are selected at random.

Work out the probability that **both** students scored more than 50 points.

Answer [2]

- 9 The diagram shows a field on horizontal ground.
The side AB is next to a straight road XY .
 $AB = 130\text{ m}$, $BC = 164\text{ m}$ and $\hat{A}BC = 115^\circ$.

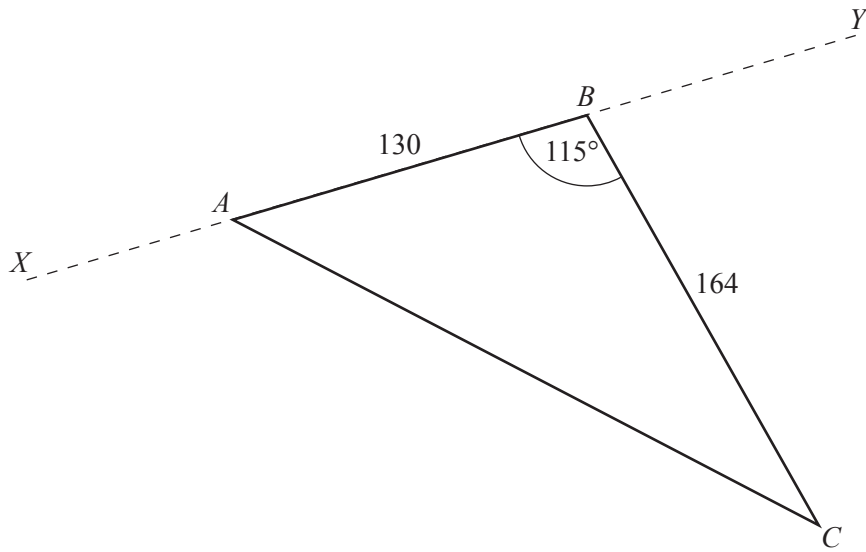

- (a) Calculate AC .

Answer m [3]

- (b) Work out the area of the field.

Answer m^2 [2]

- (c) The field is to be sown with grass seed.
Each square metre of the field is sown with 3.25 g of seed.
The seed is only sold in 5 kg bags.

How many bags of grass seed must be bought?

Answer [2]

- (d) A bird is hovering directly above B .
The angle of elevation of the bird from A is 18.5° .

Calculate the height of the bird above B .

Answer m [2]

- (e) Calculate the shortest distance from C to the road XY .

Answer m [3]

10 (a) $\mathbf{p} = \begin{pmatrix} 1 \\ -3 \end{pmatrix}$ $\mathbf{q} = \begin{pmatrix} -2 \\ 0 \end{pmatrix}$

(i) Find $|\mathbf{p}|$.

Answer [1]

(ii) On the unit grid below, draw and label the vector $\mathbf{p} - \mathbf{q}$.

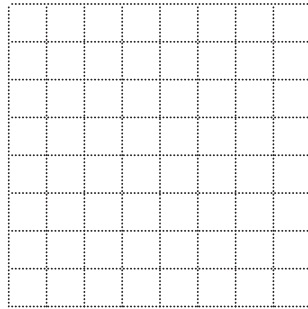

[2]

(iii) The vector \mathbf{r} is shown on the unit grid below.

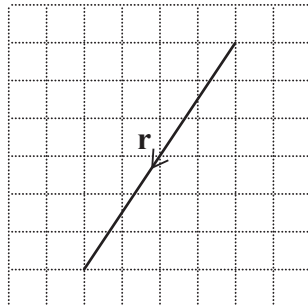

It is given that $\mathbf{r} = a\mathbf{p} + b\mathbf{q}$.

Find the values of a and b .

Answer $a =$

$b =$ [2]

(b) The diagram shows triangles A and B .

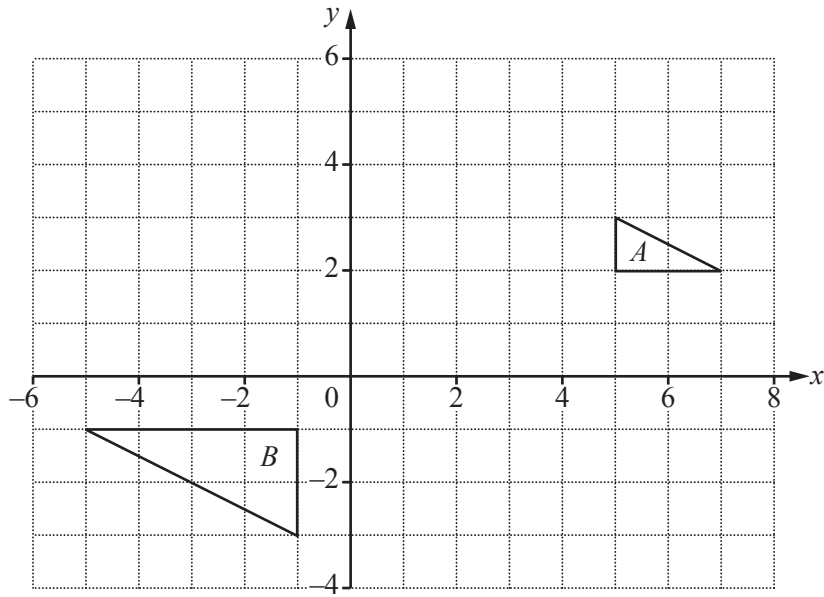

(i) Describe fully the **single** transformation that maps triangle A onto triangle B .

Answer

..... [3]

(ii) The transformation represented by the matrix $\begin{pmatrix} 1 & 0 \\ 0 & 2 \end{pmatrix}$ maps triangle A onto triangle C .

(a) Find the coordinates of the vertices of triangle C .

Answer (.....,), (.....,), (.....,) [2]

(b) Describe fully the **single** transformation that maps triangle A onto triangle C .

Answer

..... [2]

- 11 Imran drives a distance of 180 km on a business trip.
He drives the first 100 km at an average speed of x km/h.
He drives at an average speed 5 km/h slower than this for the remainder of the journey.

(a) Find, in terms of x , an expression for the time taken, in hours, for the first 100 km.

Answer hours [1]

(b) Given that the journey takes a total of 2 hours 30 minutes, form an equation in x and show that it simplifies to $x^2 - 77x + 200 = 0$.

[4]

(c) Solve the equation $x^2 - 77x + 200 = 0$, giving each answer correct to 2 decimal places.

Answer $x =$ or [4]

- (d) Which of the solutions in **part (c)** represents the speed for the first 100 km of Imran's trip?
Give a reason for rejecting the other solution.

Answer km/h because
..... [1]

- (e) Find the difference between the times taken for the first and second parts of the journey.
Give your answer in minutes, correct to the nearest minute.

Answer minutes [2]

BLANK PAGE

Permission to reproduce items where third-party owned material protected by copyright is included has been sought and cleared where possible. Every reasonable effort has been made by the publisher (UCLES) to trace copyright holders, but if any items requiring clearance have unwittingly been included, the publisher will be pleased to make amends at the earliest possible opportunity.

Cambridge International Examinations is part of the Cambridge Assessment Group. Cambridge Assessment is the brand name of University of Cambridge Local Examinations Syndicate (UCLES), which is itself a department of the University of Cambridge.