

CANDIDATE
NAME

CENTRE
NUMBER

--	--	--	--	--

CANDIDATE
NUMBER

--	--	--	--



MATHEMATICS (SYLLABUS D)

4024/21

Paper 2

October/November 2016

2 hours 30 minutes

Candidates answer on the Question Paper.

Additional Materials: Geometrical instruments
 Electronic calculator

READ THESE INSTRUCTIONS FIRST

Write your Centre number, candidate number and name on all the work you hand in.

Write in dark blue or black pen.

You may use an HB pencil for any diagrams or graphs.

Do not use staples, paper clips, glue or correction fluid.

DO NOT WRITE IN ANY BARCODES.

Section A

Answer **all** questions.

Section B

Answer any **four** questions.

If working is needed for any question it must be shown in the space below that question.

Omission of essential working will result in loss of marks.

You are expected to use an electronic calculator to evaluate explicit numerical expressions.

If the degree of accuracy is not specified in the question, and if the answer is not exact, give the answer to three significant figures. Give answers in degrees to one decimal place.

For π , use either your calculator value or 3.142, unless the question requires the answer in terms of π .

The number of marks is given in brackets [] at the end of each question or part question.

The total of the marks for this paper is 100.

This document consists of **23** printed pages and **1** blank page.

Section A [52 marks]

Answer **all** the questions in this section.

1 (a) In 2016, the price of a television is \$1995.

(i) Afzal pays the \$1995 with a deposit of \$399 and 12 equal monthly payments.

Calculate Afzal's monthly payment.

Answer \$ [1]

(ii) What percentage of \$1995 is \$399?

Answer % [1]

(iii) The price of the television in 2016 is 5% more than the price in 2015.

Calculate the price in 2015.

Answer \$ [2]

- (b) Afzal watched a programme that lasted 2 hours 53 minutes.
It ended at 01 15.

At what time did it start?

Answer [1]

- (c) A company paid a quarter of a million dollars for an advertisement that lasted 38 seconds.

Calculate the cost, correct to the nearest hundred dollars, for each second of the advertisement.

Answer \$ [2]

- (d) The programme showed an athlete running 100 metres, measured correct to the nearest metre.
The time the athlete took was 11.3 seconds, measured correct to the nearest 0.1 second.

Calculate the upper bound of the athlete's average speed.

Answer m/s [2]

2 (a) Evaluate $\sqrt[3]{\frac{543}{28.6 - 1.35}}$.

Answer [1]

(b) Factorise completely $9p^2 - 6pq$.

Answer [1]

(c) Expand the brackets and simplify $(3a + b)^2$.

Answer [1]

(d) Express as a single fraction in its simplest form $\frac{4}{2t+1} - \frac{3}{3t+1}$.

Answer [3]

(e) Find the integer values of n such that

$$4(2 - n) > 17 \text{ and}$$

$$n > -6.$$

Answer [2]

(f) Abebi, Bella and Chuku share \$112.

Abebi receives \$ x .

Bella receives \$12 less than Abebi.

Chuku receives twice as much as Bella.

Form an equation in x and solve it to find how much Chuku receives.

Answer \$ [3]

3

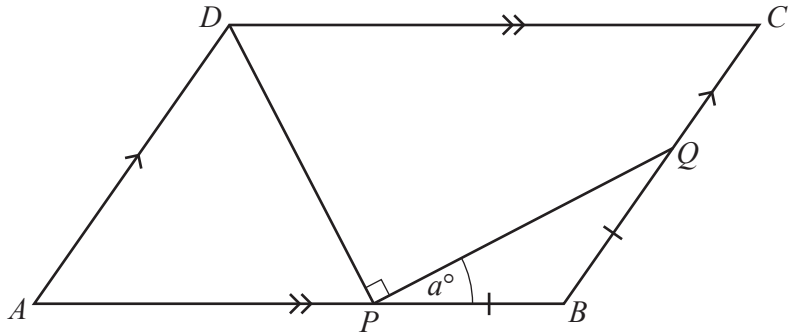

In the diagram, $ABCD$ is a parallelogram.

P and Q are points on AB and BC respectively, such that $PB = BQ$ and $\hat{D}PQ = 90^\circ$.
 $\hat{B}PQ = a^\circ$.

- (a) Find an expression, in terms of a , for each of the following angles.
 Give each answer in its simplest form.

(i) $\hat{P}BQ$

Answer [1]

(ii) $\hat{A}PQ$

Answer [1]

(iii) $\hat{D}AP$

Answer [1]

(iv) $\hat{A}DP$

Answer [1]

(b) $AB = 8$ cm and $AD = 4.7$ cm.

(i) Find PB .

Answer cm [1]

(ii) Given also that $\hat{DAB} = 54^\circ$, calculate the area of the parallelogram.

Answer cm² [2]

4 [The volume of a sphere is $\frac{4}{3}\pi r^3$]

[The surface area of a sphere is $4\pi r^2$]

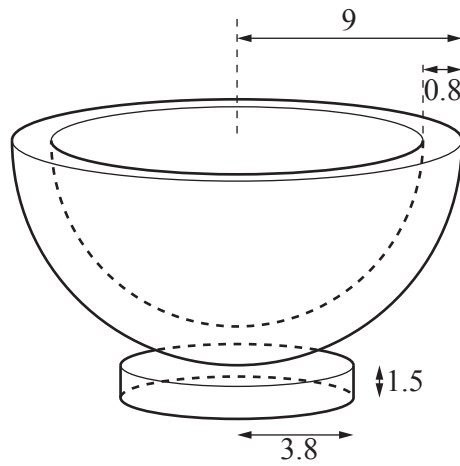

A hemispherical bowl is made of material that is 0.8 cm thick.

The outside rim of the bowl has radius 9 cm.

The bowl is attached to a base which is a solid cylinder, of radius 3.8 cm and height 1.5 cm.

(a) Calculate the surface area of the **inside** of the hemispherical bowl.

Answer cm² [2]

(b) Calculate the **total** volume of material used to make the bowl and the base.

Answer cm³ [5]

5

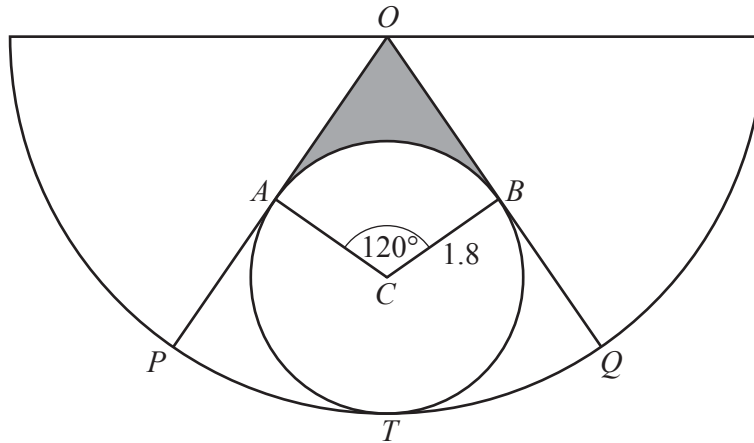

The diagram shows a semicircle with radii OP and OQ drawn.
 The circle, centre C , touches the radii at A and B and the semicircle at T .
 The radius of the circle is 1.8 cm.
 $\widehat{BCA} = 120^\circ$.

(a) Calculate the length of the minor arc AB .

Answer cm [2]

(b) The shaded region lies between the circle and the radii OP and OQ .

Calculate the perimeter of this shaded region.

Answer cm [3]

(c) (i) Show that the radius of the semicircle is 5.4 cm.

[2]

(ii) Calculate the length of BQ .

Answer cm [1]

6

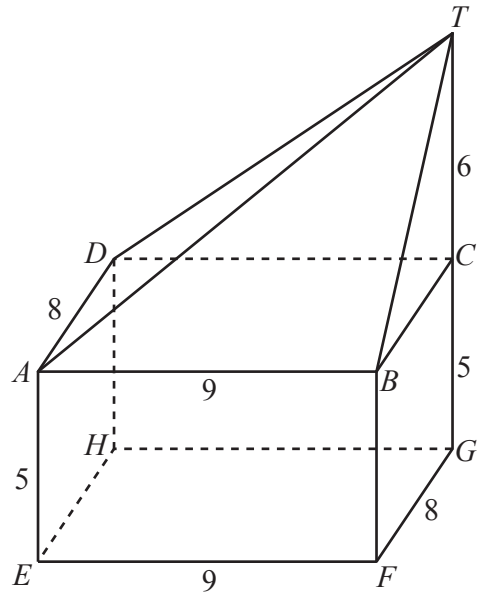

The four walls of a building are faces of a cuboid $ABCDEFGH$.
 T is vertically above C and G , so $\hat{A}BT = \hat{A}DT = 90^\circ$.

The cuboid has length 9 m, width 8 m and height 5 m.
 $TC = 6$ m.

(a) Calculate the length of DT .

Answer m [2]

(b) The roof is formed by four triangles, ABT , BCT , CDT and DAT .

Calculate the **total** surface area of the roof.

Answer m² [3]

- (c) [The volume of a pyramid is $\frac{1}{3} \times \text{area of base} \times \text{perpendicular height}$]

Calculate the **total** volume of the building.

Answer m³ [2]

- (d) Calculate the angle of elevation of T from H .

Answer [3]

Section B [48 marks]

Answer **four** questions in this section.

Each question in this section carries 12 marks.

7

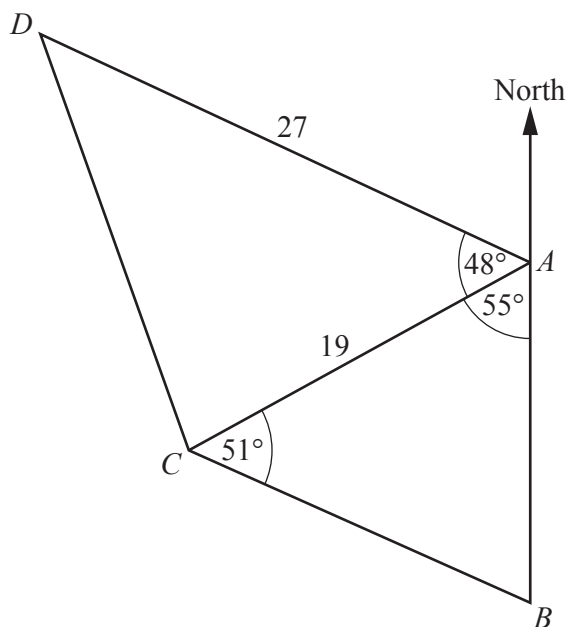

The diagram shows the positions of four islands at A , B , C and D .

A is due north of B .

$\hat{D}AC = 48^\circ$, $\hat{C}AB = 55^\circ$ and $\hat{B}CA = 51^\circ$.

$AC = 19$ km and $AD = 27$ km.

(a) Calculate the bearing of D from A .

Answer [1]

(b) Calculate the bearing of A from C .

Answer [1]

(c) Calculate the distance between A and B .

Answer km [3]

(d) Calculate the distance between D and C .

Answer km [3]

(e) A boat leaves D and sails, at a constant speed, in a straight line to A .
It takes 3 hours and 36 minutes to sail from D to A .
 X is the point on DA that is closest to C .

Calculate the time, correct to the nearest minute, the boat takes to travel from D to X .

Answer [4]

8

$$y = \frac{3}{5} \times 2^x$$

The table shows some values of x and the corresponding values of y , correct to one decimal place where necessary.

x	-1.5	-1	0	1	2	2.5	3	3.5	4
y	p	0.3	0.6	1.2	2.4	3.4	4.8	6.8	9.6

(a) Calculate p .

Answer [1]

(b) On the grid,

- using a scale of 2 cm to 1 unit, draw a horizontal x -axis for $-2 \leq x \leq 4$,
- using a scale of 1 cm to 1 unit, draw a vertical y -axis for $0 \leq y \leq 10$,
- plot the points from the table and join them with a smooth curve.

[3]

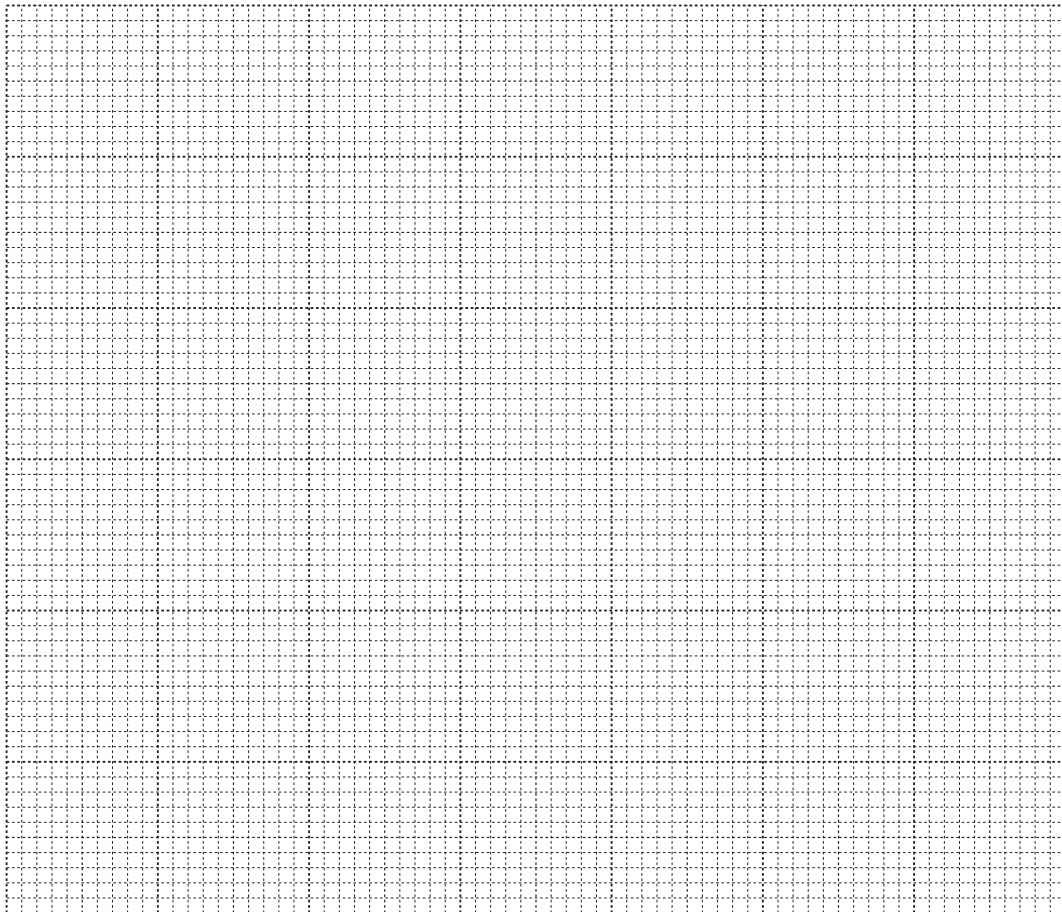

(c) By drawing a tangent, estimate the gradient of the curve at the point where $x = 2.5$.

Answer [2]

(d) (i) On the same grid, draw the straight line that passes through $(-0.4, 0)$ and $(2, 3.6)$.

[1]

(ii) Find the equation of this line in the form $y = mx + c$.

Answer [2]

(iii) Write down the x -coordinates of the points where the line intersects the curve.

Answer $x = \dots\dots\dots$ and $x = \dots\dots\dots$ [1]

(iv) These x -coordinates satisfy the equation

$$2^x = Ax + B.$$

Find the values of A and B .

Answer $A = \dots\dots\dots$ $B = \dots\dots\dots$ [2]

9 On Monday, Abdul sold 140 boxes of matches at 30 cents per box.

(a) Calculate the income, in dollars, Abdul received on Monday.

Answer \$ [1]

(b) On Tuesday, the price per box decreased by 10% and the number of boxes sold increased by 30%.

Calculate the percentage change in the income.

Answer % [3]

(c) On Wednesday, the price of a box was y cents less than it was on Monday.

Abdul sold $4y$ more boxes on Wednesday than he did on Monday.

(i) Write down an expression, in terms of y , for the income received on Wednesday.
Give your answer in dollars.

Answer \$ [2]

- (ii) Given that this income is equal to \$40, write down an equation in y and show that it simplifies to

$$y^2 + 5y - 50 = 0.$$

[2]

- (iii) Solve the equation $y^2 + 5y - 50 = 0$.

Answer $y = \dots\dots\dots$ or $\dots\dots\dots$ [3]

- (iv) Hence find the number of boxes sold on Wednesday.

Answer $\dots\dots\dots$ [1]

- 10 (a) The times taken by 135 runners to complete a cross-country course were recorded. The results are summarised in the table.

Time (t minutes)	$20 < t \leq 30$	$30 < t \leq 35$	$35 < t \leq 40$	$40 < t \leq 50$	$50 < t \leq 70$
Number of runners	15	30	40	35	15

- (i) On the grid, draw a histogram to represent this information.

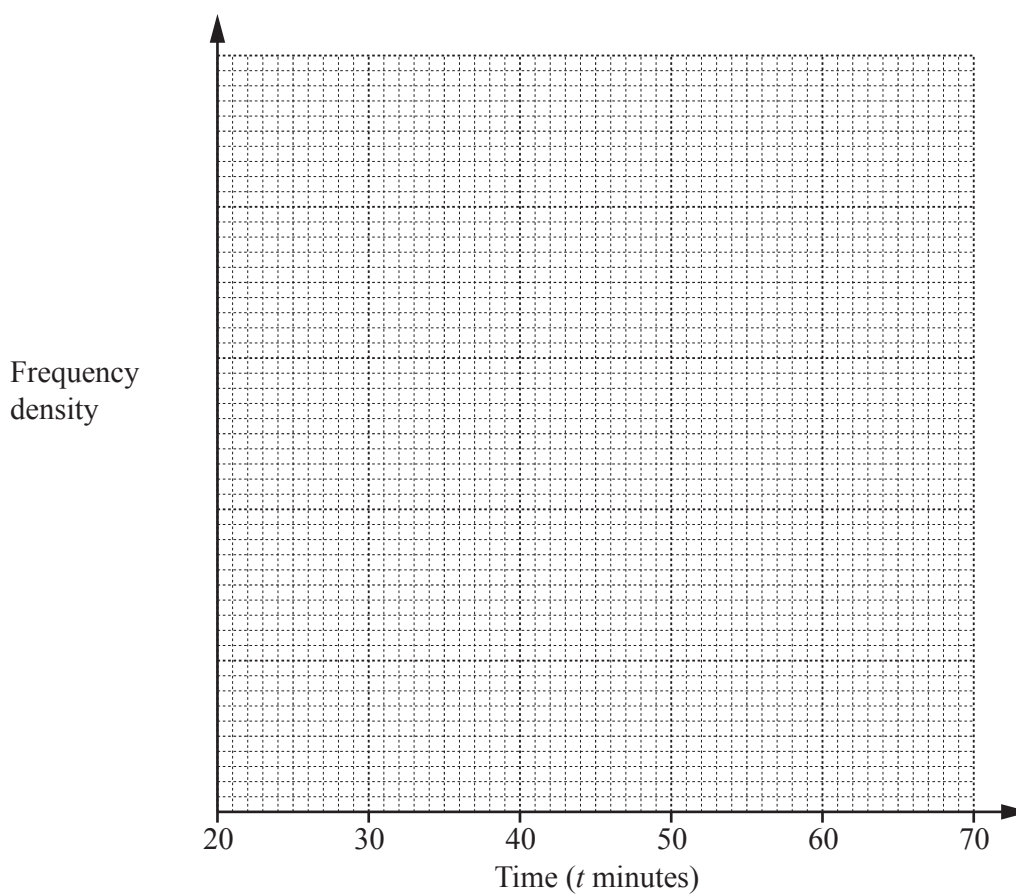

[3]

- (ii) Calculate an estimate of the mean time.

Answer minutes [3]

- (b) A bag contains R red beads and B blue beads.
Two beads are chosen, at random, without replacement.
The tree diagram shows the possible outcomes and their probabilities.

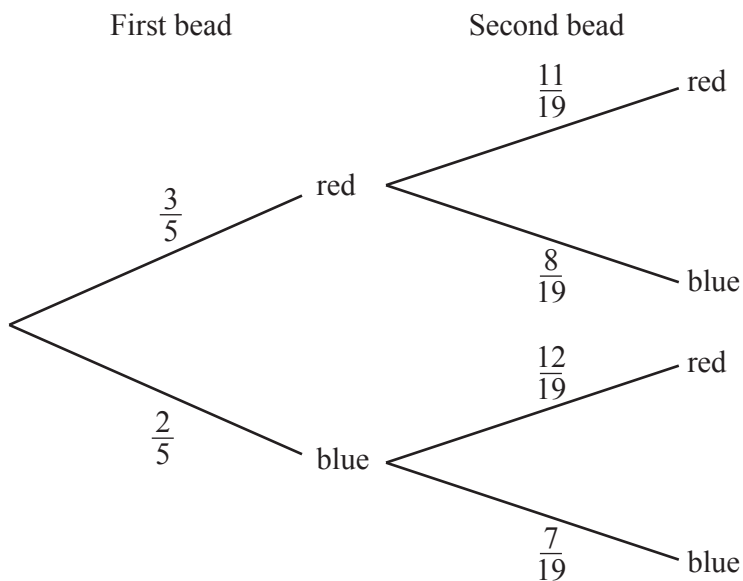

- (i) Calculate the probability that both beads are red.

Answer [1]

- (ii) Calculate the probability that the two beads are different colours.

Answer [2]

- (iii) What is the value of R ?

Answer [1]

- (iv) Of the red beads, half have a yellow spot.

Calculate the probability that, of the two chosen beads, **neither** has a yellow spot.

Answer [2]

11 (a)

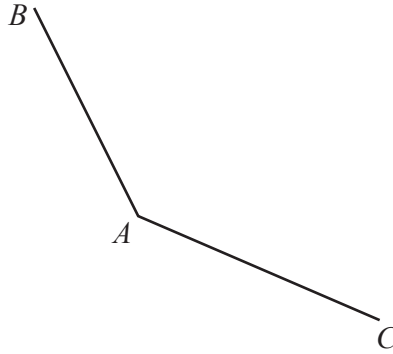

In the diagram, $\vec{AB} = \begin{pmatrix} -6 \\ 11 \end{pmatrix}$, $\vec{AC} = \begin{pmatrix} 12 \\ -5 \end{pmatrix}$.

(i) Find $|\vec{AC}|$.

Answer [2]

(ii) D is the point such that $\vec{AD} = \begin{pmatrix} 0 \\ k \end{pmatrix}$, where $k > 0$.

BD is parallel to AC .

(a) Show that $\vec{BD} = \begin{pmatrix} 6 \\ k-11 \end{pmatrix}$.

[1]

(b) Find k .

Answer $k =$ [2]

(c) Find the difference between the lengths of AD and AC .

Answer [1]

(b)

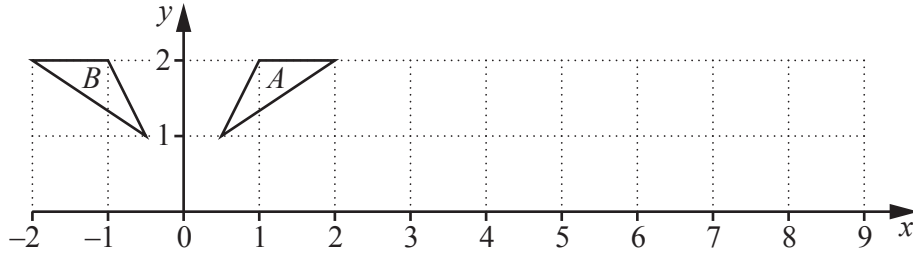

Triangle *A* has vertices $(\frac{1}{2}, 1)$, $(1, 2)$ and $(2, 2)$.

Triangle *B* has vertices $(-\frac{1}{2}, 1)$, $(-1, 2)$ and $(-2, 2)$.

(i) Describe fully the **single** transformation that maps triangle *A* onto triangle *B*.

Answer

..... [2]

(ii) Triangle *A* is mapped onto triangle *C* by a transformation represented by the matrix $\begin{pmatrix} 1 & 3 \\ 0 & 1 \end{pmatrix}$.

(a) Calculate the coordinates of the vertices of triangle *C*.

Answer (..... ,) (..... ,) (..... ,) [2]

(b) Find the matrix which represents the transformation that maps triangle *B* onto triangle *C*.

Answer $\begin{pmatrix} & \\ & \end{pmatrix}$ [2]

BLANK PAGE

Permission to reproduce items where third-party owned material protected by copyright is included has been sought and cleared where possible. Every reasonable effort has been made by the publisher (UCLES) to trace copyright holders, but if any items requiring clearance have unwittingly been included, the publisher will be pleased to make amends at the earliest possible opportunity.

To avoid the issue of disclosure of answer-related information to candidates, all copyright acknowledgements are reproduced online in the Cambridge International Examinations Copyright Acknowledgements Booklet. This is produced for each series of examinations and is freely available to download at www.cie.org.uk after the live examination series.

Cambridge International Examinations is part of the Cambridge Assessment Group. Cambridge Assessment is the brand name of University of Cambridge Local Examinations Syndicate (UCLES), which is itself a department of the University of Cambridge.