

UNIVERSITY OF CAMBRIDGE INTERNATIONAL EXAMINATIONS  
General Certificate of Education Ordinary Level

**PHYSICS**

**5054/03**

Paper 3 Practical Test

October/November 2006

**CONFIDENTIAL INSTRUCTIONS**

**Great care should be taken to ensure that any confidential information given does not reach the candidates either directly or indirectly.**

If you have any problems or queries regarding these Instructions, please contact CIE  
by e-mail: [International@cie.org.uk](mailto:International@cie.org.uk),  
by phone: +44 1223 553554,  
by fax: +44 1223 553558,  
stating the Centre number, the nature of the query and the syllabus number quoted above.

This document consists of **10** printed pages and **2** blank pages.



## Instructions for preparing apparatus

These instructions detail the apparatus required for each experiment in this paper. No access is permitted to the Question Paper in advance of the examination session.

## Number of sets of apparatus

In addition to a few spare sets, the minimum number of sets of apparatus to be provided should be sufficient to enable candidates to spend 20 minutes with the apparatus for each of Questions 1, 2 and 3, and one hour with the apparatus for Question 4. The order in which candidates answer the questions will be determined by the Supervisor. Candidates may spend one hour circulating around Questions 1, 2 and 3, followed by an hour on Question 4, or vice versa.

Extra graph paper should be available. It is assumed that candidates will supply their own calculator and geometrical instruments, such as a set square,  $0^\circ$  to  $180^\circ$  protractor, pair of compasses and 30 cm rule. Candidates should be advised in advance that they may, if they wish, use quartz wristwatches with stopwatch facilities, providing that such wristwatches afford the required precision.

## Instructions for the supervision of the examination

The Supervisor, who may be a Physics teacher, is responsible for the administration of the examination according to the procedures detailed in the Handbook for Centres. In all instances, a Physics teacher should be present. Preferably, this teacher should have been responsible for the preparation of the apparatus. Two invigilators must be present at all times: it is not acceptable for a teacher who has been responsible for preparing the candidates for this paper to be the sole Supervisor or Invigilator.

Supervisors may make the following announcement at the start of the examination.

'The Examiners do not want you to waste time when you are unable to do any experiment. Any candidate who is unable to get results with an experiment may ask for help. The extent of this help will be reported to the Examiners, who may make a deduction of marks.'

Supervisors should note that a candidate may only be given enough assistance to allow some raw readings or observations to be made. On no account should any assistance be given with the treatment or analysis of these readings and observations.

Supervisors may draw to the attention of the candidates any significant deviation between the apparatus provided and that detailed in the Question Paper, particularly where diagrams are given in the paper.

Candidates should be reminded that all their work should be written on the printed Answer Booklet. Rough paper must not be used.

The Supervisor must complete the Report at the back of these Instructions. Details should be given of any significant deviation between the apparatus used and that specified in these Instructions. A sample set of results can often help Examiners. A copy of this Report must be included in **each** packet of scripts.

**1 Items to be supplied by the Centre (per set of apparatus, unless otherwise specified)**

Bi-convex converging lens of focal length approximately 15 cm.

Two set squares.

Metre rule.

Small piece of Blu-tack.

**Notes**

- (i) The small piece of Blu-tack will be used by the candidate to support the lens vertically on the metre rule.
- (ii) The two set squares will be used like the jaws of Vernier calipers when the candidates make measurements on the lens.
- (iii) At the changeover, Supervisors should dismantle any apparatus left set up by the candidate.

**Information required by examiners**

Focal length of the lens used.

**2 Items to be supplied by the Centre (per set of apparatus, unless otherwise specified)**

d.c. power supply of approximately 3 V, e.g. two 1.5 V cells in a cell holder.

NORP 12 light-dependent resistor or equivalent.

Voltmeter capable of reading up to 5 V to a precision of 0.1 V. A 20 V digital meter would be suitable.

Milliammeter capable of reading up to 10 mA to a precision of 0.1 mA. A digital multimeter set to 20 mA would be suitable.

Switch.

Six connecting leads to enable the Supervisor to set up the circuit shown in Fig. 2.1.

White paper disc with a diameter slightly greater than that of the LDR.

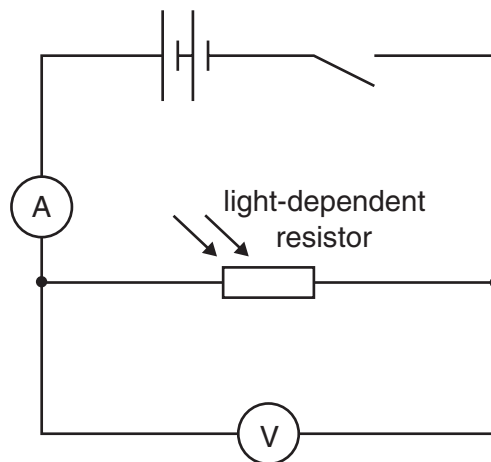

**Fig. 2.1**

**Notes**

- (i) The light-dependent resistor (LDR) should have suitable terminals to enable it to be connected into the remainder of the circuit. Crocodile clips may be suitable.
- (ii) The Supervisor should set up the circuit as shown in Fig. 2.1. The Supervisor should check that it is possible to obtain a reading on the ammeter when the LDR is exposed to normal background light intensity. To obtain a suitable reading it may be necessary for the Supervisor to change the range of the meter, the voltage of the power supply, or the light level at the LDR (e.g. by providing a lamp).

- (iii) The paper disc may be cut from a plain sheet of white photocopier paper.
- (iv) When the LDR is covered by the disc, the current should drop to approximately 20% of its former value. If the current does not drop to this value, a different thickness of paper should be used. Candidates will be required to measure this current.
- (v) At the changeover, Supervisors should check that the circuit is still set up as described above. The switch should be open.

**Information required by examiners**

Current through the LDR when covered by the disc and when uncovered.

**3 Items to be supplied by the Centre (per set of apparatus, unless otherwise specified)**

Plane mirror in a holder which enables the face of the mirror to be placed vertically with one edge on the bench.

Four optics pins.

Soft board of at least A4 size.

Protractor.

**Notes**

- (i) Candidates will place their Answer Booklet on the soft board and will stick pins through the booklet and into the board.
- (ii) If a soft board is not available, a flat polystyrene tile or other soft flat surface may be used as an alternative.

**Information required by examiners**

None.

#### 4 Items to be supplied by the Centre (per set of apparatus, unless otherwise specified)

Glass sphere of diameter between 1.0 cm and 2.0 cm, e.g. a glass marble.

Wooden block of height approximately 10 cm.

Two stiff wooden metre rules.

Small piece of Blu-tack.

Stopwatch reading to 0.1 s or better (a digital stopwatch is suitable).

Cloth or pile of paper towels.

#### Notes

- (i) The wooden metre rules and wooden block should be set up by the Supervisor to form a ramp, as shown in Fig. 4.1 and Fig. 4.2.

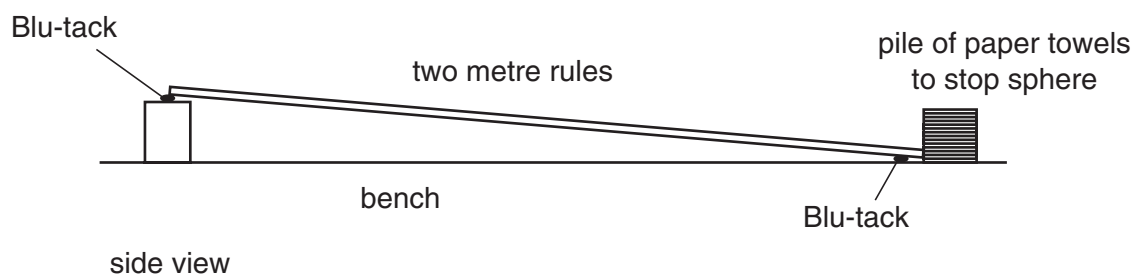

Fig. 4.1

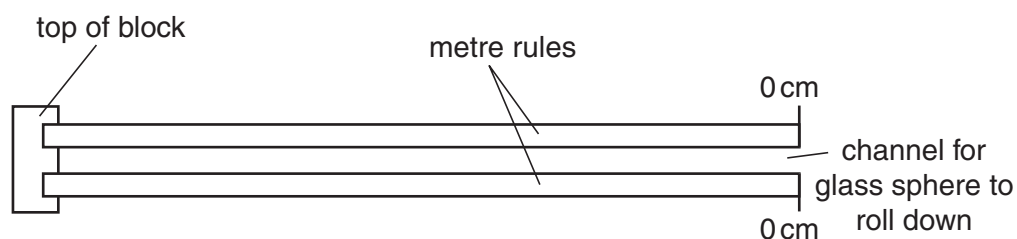

Fig. 4.2

- (ii) The zero end of both metre rules should be in contact with the bench. The channel between the two rules should be approximately two thirds the diameter of the glass sphere.
- (iii) Supervisors should check that a glass sphere takes approximately 2 seconds to roll a distance of approximately 80 cm down the ramp. If the time needs to be adjusted to 2 seconds, Supervisors should either use a block of different height or adjust the position of the block beneath the rules. Once the correct time is achieved, the rules should be secured to the block and bench by means of Blu-tack.

- (iv) If the two rules sag in the middle when they have been set up, an additional block of wood may be required to support the rules approximately half-way along their length. This is particularly important if one rule sags more than the other. The glass sphere must not roll off the side.
- (v) The pile of paper towels is placed at the end of the ramp to stop the sphere.
- (vi) Spare glass spheres should be available.
- (vii) At the changeover, the Supervisor should check that the apparatus is still set up as described above, with the glass sphere at the end of the runway.

**Information required by examiners**

None.



**BLANK PAGE**

**BLANK PAGE**

---

Permission to reproduce items where third-party owned material protected by copyright is included has been sought and cleared where possible. Every reasonable effort has been made by the publisher (UCLES) to trace copyright holders, but if any items requiring clearance have unwittingly been included, the publisher will be pleased to make amends at the earliest possible opportunity.

University of Cambridge International Examinations is part of the University of Cambridge Local Examinations Syndicate (UCLES), which is itself a department of the University of Cambridge.

**This form must be completed and returned with the Answer Booklets.**

### REPORT ON PRACTICAL PHYSICS

The Supervisor is asked to give the following details, using the space provided on page 12.

- (a) Information required at the end of the test, as indicated in the Instructions.
- (b) Any help given to a candidate.
- (c) Any general difficulties encountered in preparing the apparatus.
- (d) Any difficulties experienced by particular candidates. These should include reference to difficulties due to faulty apparatus or materials and accidental damage to apparatus or materials. Candidates should be identified by name and candidate number.

Other cases of hardship, such as disability or illness, should be reported to CIE in the normal way.

The Supervisor is asked to provide a plan of the work benches, giving details by candidate numbers of the places occupied by the candidates for each session. The plan should be enclosed with the Answer Booklets, together with the Information required by Examiners.

#### Declaration to be signed by the Principal

The preparation of this practical examination has been carried out so as fully to maintain the security of the examination.

Signed .....

Name (in block capitals) .....

Centre Number .....

Centre Name .....



**Information required**

Focal length of the lens used in question 1:

focal length = .....

Current in the LDR used in question 2:

current when LDR is covered = .....

current when LDR is uncovered = .....

**Details of difficulties and any help given to candidates**