



UNIVERSITY OF CAMBRIDGE INTERNATIONAL EXAMINATIONS
General Certificate of Education Ordinary Level

PHYSICS

5054/03

Paper 3 Practical Test

October/November 2007

CONFIDENTIAL INSTRUCTIONS

Great care should be taken to ensure that any confidential information given does not reach the candidates either directly or indirectly.

No access to the Question Paper is permitted in advance of the examination.

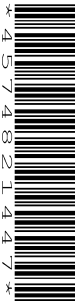

If you have any problems or queries regarding these Instructions, please contact CIE
by e-mail: International@cie.org.uk,
by phone: +44 1223 553554,
by fax: +44 1223 553558,
stating the Centre number, the nature of the query and the syllabus number quoted above.

This document consists of **9** printed pages and **3** blank pages.



Instructions for preparing apparatus

These instructions detail the apparatus required for each experiment in this paper. No access is permitted to the Question Paper in advance of the examination session.

Number of sets of apparatus

In addition to a few spare sets, the minimum number of sets of apparatus to be provided should be sufficient to enable candidates to spend 20 minutes with the apparatus for each of Questions 1, 2 and 3, and one hour with the apparatus for Question 4. The order in which candidates answer the questions will be determined by the Supervisor. Candidates may spend one hour circulating around Questions 1, 2 and 3, followed by an hour on Question 4, or vice versa.

Extra graph paper should be available. It is assumed that candidates will supply their own calculator and geometrical instruments, such as a set square, 0° to 180° protractor, pair of compasses and 30 cm rule. Candidates should be advised in advance that they may, if they wish, use quartz wristwatches with stopwatch facilities, providing that such wristwatches afford the required precision.

Instructions for the supervision of the examination

The Supervisor, who may be a Physics teacher, is responsible for the administration of the examination according to the procedures detailed in the Handbook for Centres. In all instances, a Physics teacher should be present. Preferably, this teacher should have been responsible for the preparation of the apparatus. Two invigilators must be present at all times: it is not acceptable for a teacher who has been responsible for preparing the candidates for this paper to be the sole Supervisor or Invigilator.

Supervisors may make the following announcement at the start of the examination.

'The Examiners do not want you to waste time when you are unable to do any experiment. Any candidate who is unable to get results with an experiment may ask for help. The extent of this help will be reported to the Examiners, who may make a deduction of marks.'

Supervisors should note that a candidate may only be given enough assistance to allow some raw readings or observations to be made. On no account should any assistance be given with the treatment or analysis of these readings and observations.

Supervisors may draw to the attention of the candidates any significant deviation between the apparatus provided and that detailed in the Question Paper, particularly where diagrams are given in the paper.

Candidates should be reminded that all their work should be written on the printed Answer Booklet. Rough paper must not be used.

The Supervisor must complete the Report at the back of these Instructions. Details should be given of any significant deviation between the apparatus used and that specified in these Instructions. A sample set of results can often help Examiners. A copy of this Report must be included in **each** packet of scripts.

1 Items to be supplied by the Centre (per set of apparatus, unless otherwise specified)

Rectangular wooden block of approximate dimensions 4 cm x 4 cm x 3 cm.

Half-metre rule.

500 cm³ glass or perspex beaker containing approximately 400 cm³ of water.

Paper towels to mop up spillages.

Notes

- (i) One of the 4 cm x 4 cm faces of the block should be labelled “Top” using a permanent marker pen.
- (ii) Supervisors should ensure that the block will fit inside the beaker with the top face of the block uppermost.
- (iii) Supervisors should ensure that the block does **not** float with the top face in a horizontal plane and that more than half of the depth of the block is below the surface of the water i.e. the density of the wood of the block should be greater than 0.5 g/cm³.
- (iv) Each corner of the block should have a scale having 5 mm divisions marked on it with a thin permanent marker pen or biro. This is shown in Fig. 1.1.

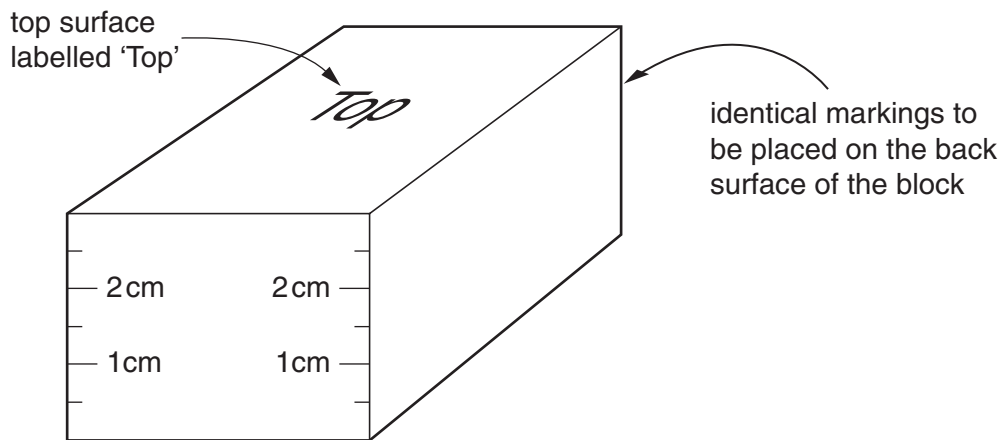

Fig. 1.1

- (v) At the changeover, Supervisors should remove the block from the water and dry it with a paper towel. Supervisors should also ensure that there is still approximately 400 cm³ of water in the beaker.

Information required by examiners

None.

2 Items to be supplied by the Centre (per set of apparatus, unless otherwise specified)

Rectangular glass or perspex block of the type used in refraction experiments.

Four optics pins.

Protractor.

Soft board (or polystyrene tile) of approximately A4 size.

Notes

- (i) The rectangular glass or perspex block should have straight rather than bevelled edges.
- (ii) The board should be soft enough to allow pins to be easily pushed in.
- (iii) At the changeover, the Supervisor should check that all the apparatus is still present.

Information required by examiners

Material of the block used by the candidates.

3 Items to be supplied by the Centre (per set of apparatus, unless otherwise specified)

Piece of stiff card cut into a right angled triangular shape with sides of 12.0cm, 16.0cm and 20.0cm (one piece of card for each candidate).

Thin string of length 60cm.

Pendulum bob or suitable mass.

Thin round nail of length approximately 4cm.

Small block of wood.

15 cm or 30cm rule with mm divisions.

Stand, clamp and boss.

Small piece of string or tag (one piece for each candidate).

Notes

- (i) The pendulum bob should be tied to the 60 cm length of string to form a plumb line.
- (ii) The thin round nail should be nailed into the block of wood so that approximately 2 cm of the nail protrudes from the wood.
- (iii) Holes should be punched in the card close to each of the corners of the triangle. The holes should be of sufficient diameter so that the hole can easily pass over the head of the nail. The corners of the triangle should be labelled **A**, **B** and **C** as shown in Fig. 3.1.

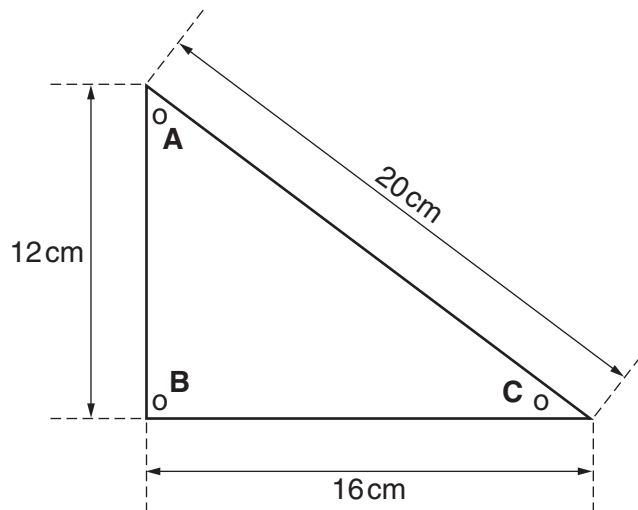

Fig. 3.1

- (iv) The small piece of string or tag is to be used by the candidate to secure the card to the Answer Booklet at the end of the examination.

- (v) At the changeover, the Supervisor should dismantle any apparatus set up by the candidate. The Supervisor should also issue a new unmarked card and small piece of string or tag to each candidate.

Information required by examiners

None.

4 Items to be supplied by the Centre (per set of apparatus, unless otherwise specified)

3 V d.c. power supply, e.g. two 1.5 V dry cells in a suitable holder.

Voltmeter capable of measuring a voltage up to 2 V to a precision of 0.01 V, a digital or analogue meter is suitable.

2.2 k Ω resistor labelled **X**.

Switch or plug key.

Three further resistors of values 470 Ω , 1.0 k Ω and 2.2 k Ω .

Connecting leads to enable the Supervisor to set up the circuit shown in Fig. 4.1.

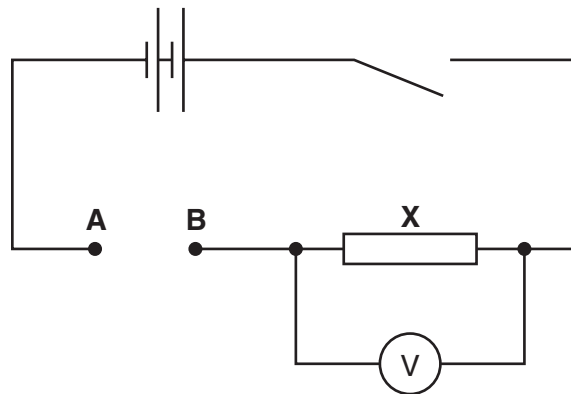

Fig. 4.1

Two further connecting leads.

Notes

- (i) The resistors should all have suitable terminations to enable them to be connected into the circuit.
- (ii) The value of the 2.2 k Ω resistor labelled **X** should be obscured from the candidates by covering the resistor in opaque tape.
- (iii) The nominal values of the other three resistors should be clearly marked on the resistors for the candidates to use. This can be done by placing masking tape around the resistor and then writing the value of the resistor on the masking tape. All values should be written in k Ω , e.g. 0.47 k Ω , 1.0 k Ω and 2.2 k Ω .
- (iv) In the circuit shown in Fig. 4.1, the points **A** and **B** should be clearly labelled.
- (v) At the changeover, the Supervisor should check that the circuit is still set up as shown in Fig. 4.1. The switch should be open. The additional resistors should be disconnected from the circuit and all the labels should still be in place.

Information required by examiners

None.

BLANK PAGE

BLANK PAGE

Permission to reproduce items where third-party owned material protected by copyright is included has been sought and cleared where possible. Every reasonable effort has been made by the publisher (UCLES) to trace copyright holders, but if any items requiring clearance have unwittingly been included, the publisher will be pleased to make amends at the earliest possible opportunity.

University of Cambridge International Examinations is part of the Cambridge Assessment Group. Cambridge Assessment is the brand name of University of Cambridge Local Examinations Syndicate (UCLES), which is itself a department of the University of Cambridge.

This form must be completed and returned with the Answer Booklets.

REPORT ON PRACTICAL PHYSICS

The Supervisor is asked to give the following details, using the space provided on page 12.

- (a) Information required at the end of the test, as indicated in the Instructions.
- (b) Any help given to a candidate.
- (c) Any general difficulties encountered in preparing the apparatus.
- (d) Any difficulties experienced by particular candidates. These should include reference to difficulties due to faulty apparatus or materials and accidental damage to apparatus or materials. Candidates should be identified by name and candidate number.

Other cases of hardship, such as disability or illness, should be reported to the Syndicate in the normal way.

The Supervisor is asked to provide a plan of the work benches, giving details by candidate numbers of the places occupied by the candidates for each session. The plan should be enclosed with the Answer Booklets, together with the information required by Examiners.

Declaration to be signed by the Principal

The preparation of this practical examination has been carried out so as fully to maintain the security of the examination.

Signed

Name (in block capitals)

Centre Number

Centre Name



Information required

Material of the block used in question 2.

material =

Details of difficulties and any help given to candidates

