

UNIVERSITY OF CAMBRIDGE INTERNATIONAL EXAMINATIONS
General Certificate of Education Ordinary Level

COMBINED SCIENCE

5129/01

Paper 1 Multiple Choice

October/November 2004

1 hour

Additional Materials: Multiple Choice Answer Sheet
Soft clean eraser
Soft pencil (type B or HB is recommended)

READ THESE INSTRUCTIONS FIRST

Write in soft pencil.

Do not use staples, paper clips, highlighters, glue or correction fluid.

Write your name, Centre number and candidate number on the answer sheet in the spaces provided unless this has been done for you.

There are **forty** questions on this paper. Answer **all** questions. For each question there are four possible answers **A, B, C, and D**.

Choose the **one** you consider correct and record your choice in **soft pencil** on the separate answer sheet.

Read the instructions on the Answer Sheet very carefully.

Each correct answer will score one mark. A mark will not be deducted for a wrong answer.

Any rough working should be done in this booklet.

A copy of the Periodic Table is included on page 20.

This document consists of **17** printed pages and **3** blank pages.



- 1 A stone falls freely under gravity.

What is meant by the acceleration of the stone?

- A The distance the stone falls in one second.
- B The increase in speed of the stone.
- C The increase in speed of the stone in one second.
- D The time for the stone to reach maximum speed.

- 2 The table shows the weights of some masses on the surface of four different planets.

Which planet has the greatest gravitational field strength?

	mass	weight
A	0.5 kg	20 N
B	2.0 kg	20 N
C	0.5 kg	40 N
D	2.0 kg	40 N

- 3 The diagrams show the same spring with different weights attached.

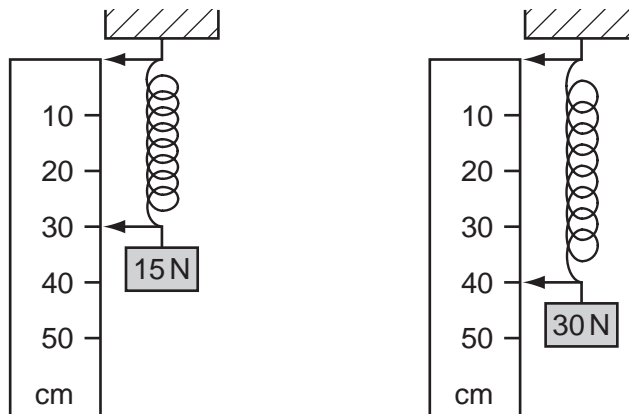

When the weights are removed, the spring returns to its original length.

What is the original length of the spring?

- A 25 cm
- B 20 cm
- C 15 cm
- D 10 cm

- 4 Brakes are used to stop a car.

What is most of the kinetic energy converted into?

- A heat energy
- B light energy
- C potential energy
- D sound energy

- 5 The diagram shows a dipper producing circular waves in a ripple tank.

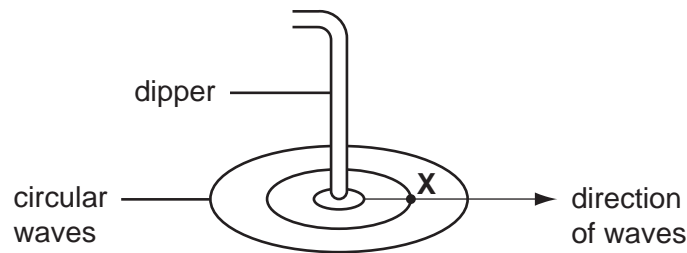

Which wave property describes the number of waves passing point X per second?

- A wavelength
 - B speed
 - C frequency
 - D amplitude
- 6 Which diagram shows a useful application of thermal expansion?

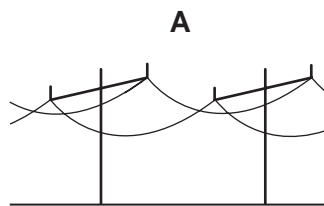

slack
telephone wires

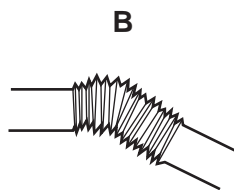

flexible joints
in steam pipes

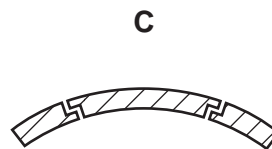

gaps in
concrete bridges

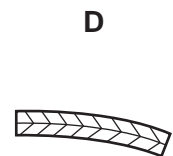

bimetallic
thermostats

- 7 What is a property of all electromagnetic waves?

- A They are deflected by magnets.
- B They are positively charged.
- C They travel at the speed of sound.
- D They travel through a vacuum.

8 Which circuit can be used to find the resistance of the lamp?

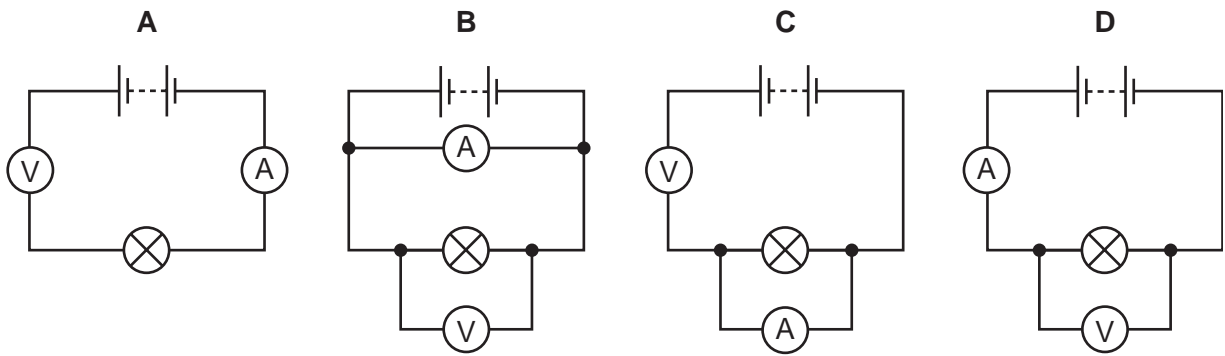

9 In the circuit shown, the brightness of the lamp can be altered by changing the resistance of the variable resistor, R.

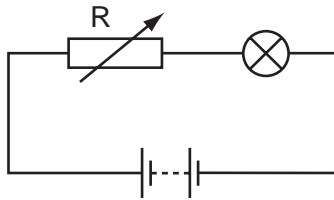

This is because varying the resistance changes

- A the current flowing in the circuit.
 - B the electromotive force (e.m.f) of the battery.
 - C the resistance of the bulb.
 - D the temperature of the battery.
- 10 A heater used on a 250V mains circuit has a 5A fuse in its plug.

Which is the highest power rating for this heater?

- A 50W
- B 250W
- C 1000W
- D 2000W

- 11 The diagram shows the north pole of a magnet moved into, and out of, a coil of wire.

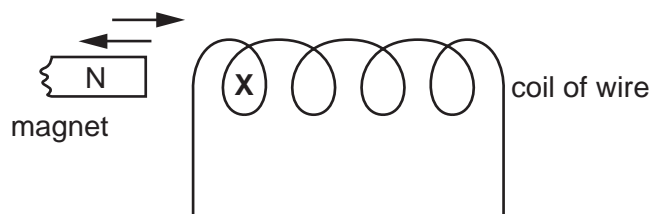

What describes the poles produced in the coil at **X** by the movement of the magnet?

	north pole in	north pole out
A	N	N
B	N	S
C	S	N
D	S	S

- 12 The table shows how the activity of a radioactive substance changes over a period of time. (Allowance has been made for the background radiation.)

time/minutes	0	5	10	15	20	25	30	35	40
activity/counts per second	114	102	90	83	73	65	57	51	45

What is the half-life of the substance?

- A** 73 minutes
B 57 minutes
C 30 minutes
D 20 minutes
- 13 What particles are present in the nucleus of the oxygen nuclide $^{17}_8\text{O}$?

	neutrons	protons
A	9	8
B	17	8
C	8	9
D	9	17

- 14 Which statement about the molecules in carbon dioxide gas is correct?
- A The molecules are close together.
 - B The molecules are diatomic.
 - C The molecules are in fixed positions.
 - D The molecules move randomly.
- 15 Which piece of apparatus would be most suitable to measure accurately the volume of acid needed to neutralise 25.0 cm^3 of an alkali?

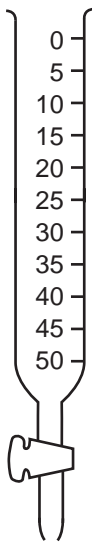

A

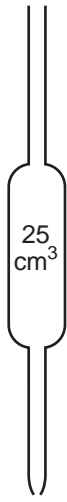

B

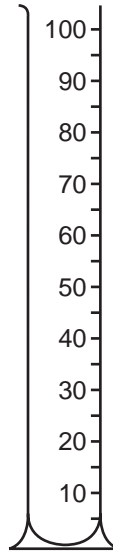

C

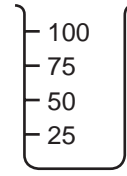

D

16 Which diagram shows the structure of a ${}^7_3\text{Li}$ atom?

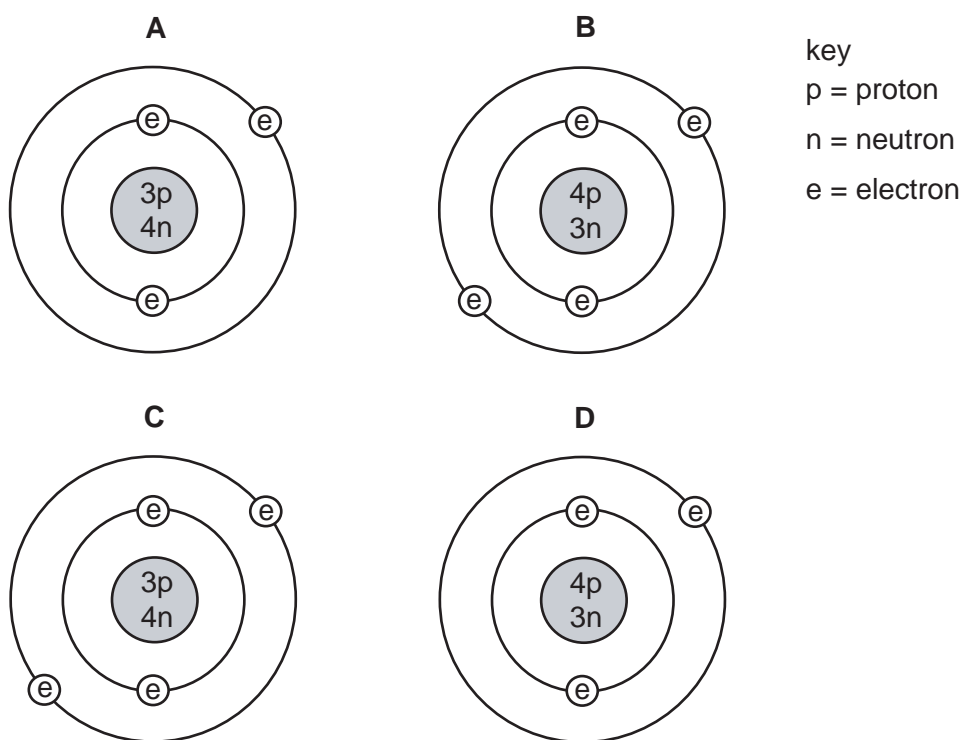

17 Which statement describes the formation of a chloride ion from a chlorine atom?

- A The atom gains one electron.
- B The atom gains two electrons.
- C The atom loses one electron.
- D The atom loses two electrons.

18 Which mass of oxygen combines with 12g of magnesium?

- A 4g
- B 8g
- C 16g
- D 32g

19 Which salt can be prepared by the reaction between a soluble metal hydroxide and dilute sulphuric acid?

- A copper(II) sulphate
- B iron(II) sulphate
- C lead(II) sulphate
- D potassium sulphate

20 Many crops will not grow well in an acidic soil.

Which type of chemical reaction takes place when farmers add calcium hydroxide to the soil?

- A decomposition
- B fertilisation
- C neutralisation
- D reduction

21 Experiments are carried out to arrange metals X, Y and Z in order of decreasing reactivity.

The table shows the results.

experiment	X	Y	Z
Does the metal liberate hydrogen from dilute hydrochloric acid?	yes	no	yes
Is the metal oxide reduced by heating with carbon?	yes	yes	no

What is the order of reactivity of the metals?

	most reactive → least reactive		
A	X	Z	Y
B	Y	X	Z
C	Z	X	Y
D	Z	Y	X

22 Iron filings are left to rust in the apparatus shown.

Which letter indicates the water level when all the oxygen has reacted?

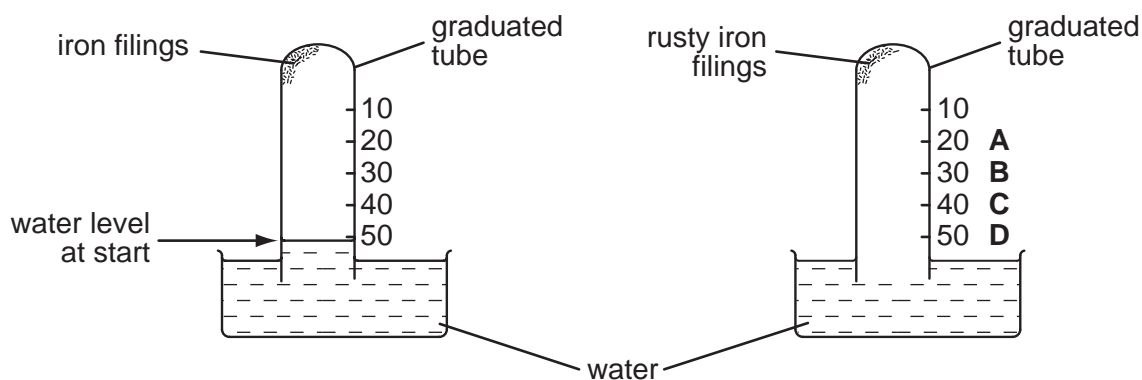

23 The following gases are present in car exhaust fumes.

- carbon dioxide
- carbon monoxide
- nitrogen
- nitrogen dioxide
- water vapour

Which of these gases is also present in unpolluted air?

- A** nitrogen only
- B** nitrogen and water vapour only
- C** nitrogen, carbon dioxide and water vapour only
- D** nitrogen, carbon monoxide, carbon dioxide and water vapour only
- 24 Which statement about the homologous series of alcohols is **not** true?
- A** They all contain oxygen.
- B** They can be represented by a general formula.
- C** They exhibit a gradual change in physical properties.
- D** They have the same empirical formula.

25 The structures of four organic compounds are shown.

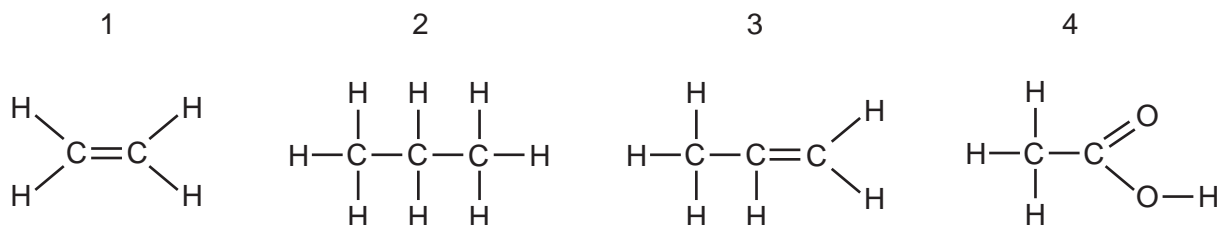

Which compounds decolourise aqueous bromine?

- A** 1 and 2 **B** 1 and 3 **C** 2 and 4 **D** 3 and 4
- 26 Methane is used as a fuel.
- Which property is essential for this use?
- A** It burns exothermically.
- B** It is a gas.
- C** It is odourless.
- D** It has a low boiling point.

27 The following formula represents a monomer.

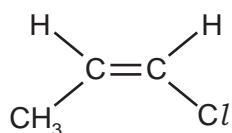

Which formula shows a part of the polymer chain formed from 3 molecules of the monomer?

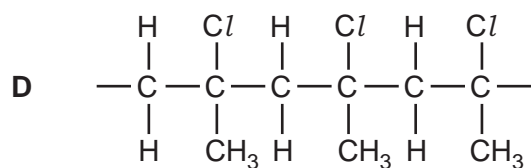
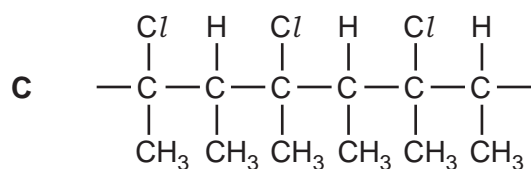
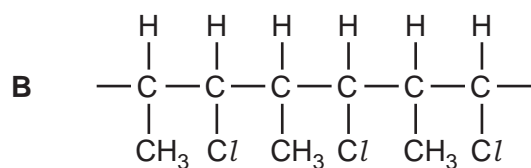
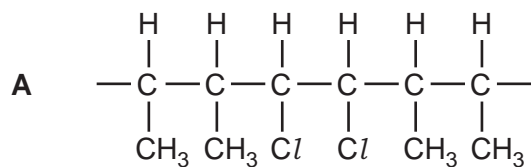

28 Which feature of a root hair cell indicates that it is from a plant and not from an animal?

- A** cell membrane
- B** cell wall
- C** chloroplast
- D** cytoplasm

- 29 The graph shows the relationship between temperature and the activity of the enzyme amylase that breaks down starch to sugar.

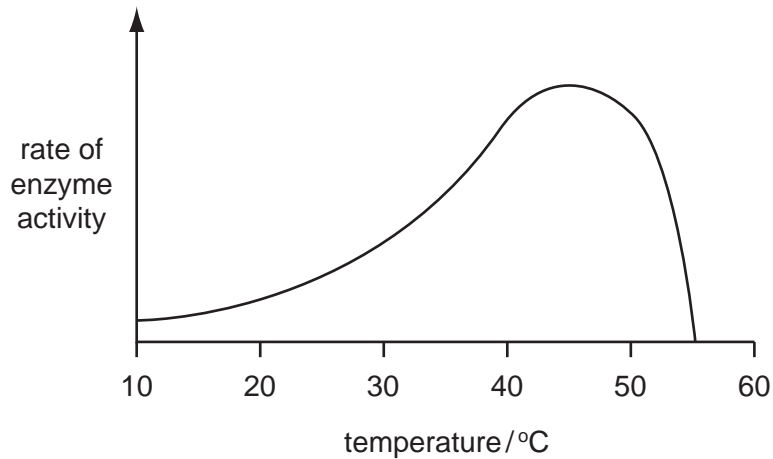

From the graph, which statement is correct?

- A Amylase works best at 55°C.
 - B Starch will not be broken down below 10°C.
 - C Sugar is produced most rapidly at 45°C.
 - D The higher the temperature, the faster the amylase works.
- 30 What is the correct equation for photosynthesis?
- A carbohydrate + oxygen → water + carbon dioxide
 - B carbohydrate + carbon dioxide → oxygen + water
 - C carbon dioxide + oxygen → carbohydrate + water
 - D carbon dioxide + water → carbohydrate + oxygen

- 31 The diagram shows some food moving along the alimentary canal by peristalsis.

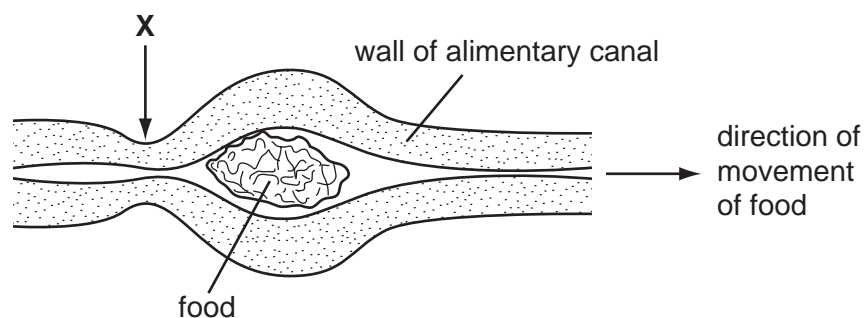

What are the muscles in the wall of the alimentary canal doing at point **X**?

	circular muscles	longitudinal muscles
A	contracting	contracting
B	contracting	relaxing
C	relaxing	contracting
D	relaxing	relaxing

- 32 A woman has fewer red blood cells than normal.

What would be the effect of this?

- A** Her blood contains high levels of urea.
B Her blood does not clot properly.
C Her body cells do not get enough oxygen.
D She cannot fight off infections.
- 33 What are the conditions in the muscles when lactic acid is produced?

	concentration of carbon dioxide	supply of oxygen
A	high	less than oxygen demand
B	high	more than oxygen demand
C	low	less than oxygen demand
D	low	more than oxygen demand

34 The diagram shows a section through the eye.

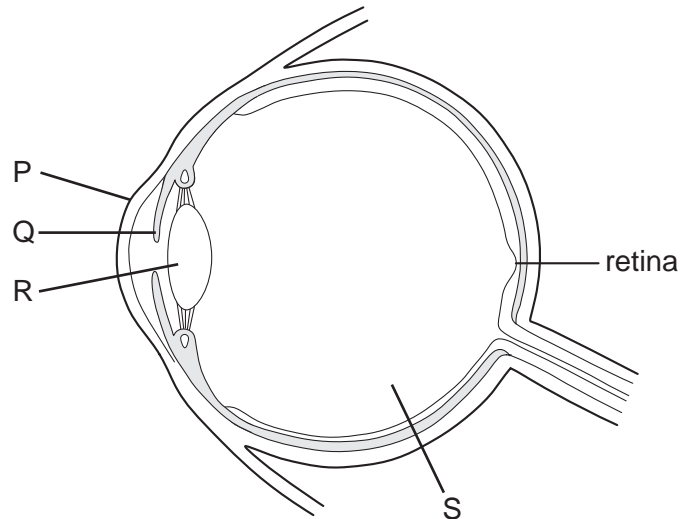

Which pair of structures focus light rays onto the retina?

- A P and Q
 - B P and R
 - C Q and R
 - D Q and S
- 35 What may happen to a heroin addict 48 hours after the drug is withdrawn?
- A Desire for the drug is reduced.
 - B The addiction is cured.
 - C Tolerance to the drug increases.
 - D Vomiting, sweating and cramp occur.

36 The diagram shows a food web from a freshwater pond.

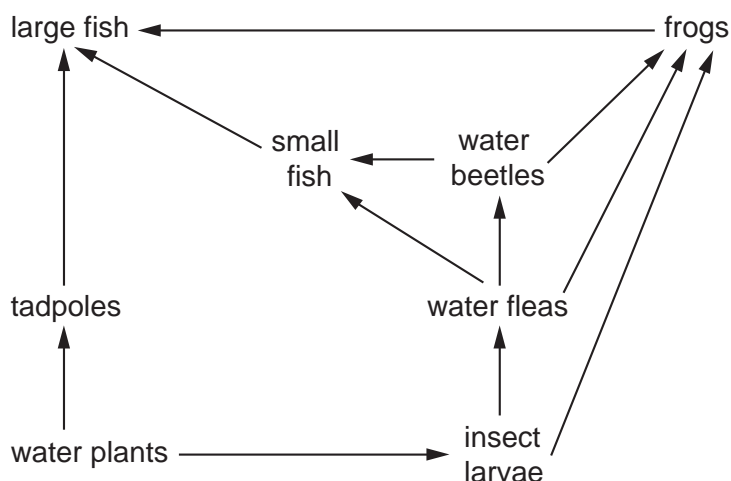

Which organisms are herbivores and which are carnivores?

	herbivores	carnivores
A	small fish	large fish
B	tadpoles	frogs
C	water fleas	insect larvae
D	water plants	water beetles

37 The diagram shows the carbon cycle.

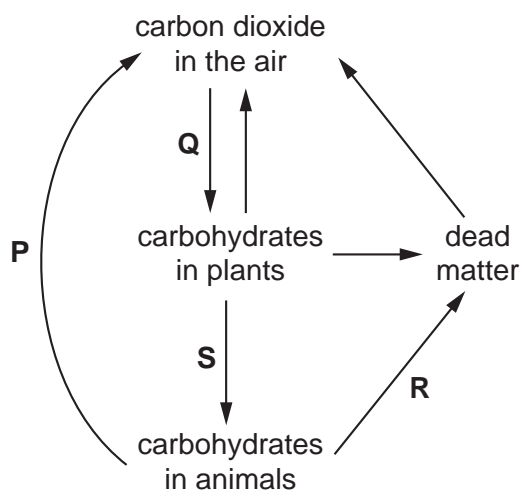

Which parts of the cycle form parts of food chains?

- A** P and Q
- B** P and S
- C** Q and R
- D** R and S

38 What conditions are needed for the germination of most seeds?

	light	oxygen	water
A	✓	✓	✗
B	✗	✓	✗
C	✓	✗	✓
D	✗	✓	✓

39 The diagram shows a section of a seed.

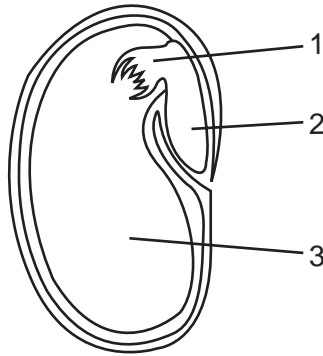

What are the numbered parts?

	1	2	3
A	cotyledon	plumule	radicle
B	plumule	cotyledon	radicle
C	plumule	radicle	cotyledon
D	radicle	plumule	cotyledon

40 The diagram shows part of the male reproductive system.

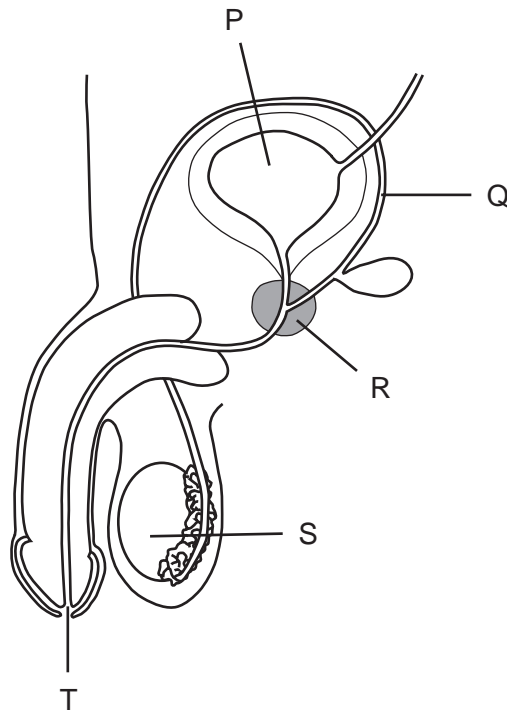

Which structures produce seminal fluid and sperm?

	seminal fluid	sperm
A	P	Q
B	Q	R
C	R	S
D	S	T

DATA SHEET

The Periodic Table of the Elements

		Group																																																																																																																																																																																																																																																																																																																																																																																																																																																																																																																																																																																																																																																																																																																																																																																	
		I	II	III	IV	V	VI	VII	0																																																																																																																																																																																																																																																																																																																																																																																																																																																																																																																																																																																																																																																																																																																																																																										
7	3	9	4	1	5	6	7	8	9	10	2																																																																																																																																																																																																																																																																																																																																																																																																																																																																																																																																																																																																																																																																																																																																																																								
Li Lithium	Be Beryllium	H Hydrogen	B Boron	C Carbon	N Nitrogen	O Oxygen	F Fluorine	Ne Neon	He Helium																																																																																																																																																																																																																																																																																																																																																																																																																																																																																																																																																																																																																																																																																																																																																																										
23	11	24	12	13	14	15	16	17	18																																																																																																																																																																																																																																																																																																																																																																																																																																																																																																																																																																																																																																																																																																																																																																										
Na Sodium	Mg Magnesium	Al Aluminium	Si Silicon	P Phosphorus	S Sulphur	Cl Chlorine	Ar Argon																																																																																																																																																																																																																																																																																																																																																																																																																																																																																																																																																																																																																																																																																																																																																																												
39	19	40	20	21	22	23	24	25	26	27	28	29	30	31	32	33	34	35	36	37	38	39	40	41	42	43	44	45	46	47	48	49	50	51	52	53	54	55	56	57	58	59	60	61	62	63	64	65	66	67	68	69	70	71	72	73	74	75	76	77	78	79	80	81	82	83	84	85	86	87	88	89	90	91	92	93	94	95	96	97	98	99	100	101	102	103	104	105	106	107	108	109	110	111	112	113	114	115	116	117	118	119	120	121	122	123	124	125	126	127	128	129	130	131	132	133	134	135	136	137	138	139	140	141	142	143	144	145	146	147	148	149	150	151	152	153	154	155	156	157	158	159	160	161	162	163	164	165	166	167	168	169	170	171	172	173	174	175	176	177	178	179	180	181	182	183	184	185	186	187	188	189	190	191	192	193	194	195	196	197	198	199	200	201	202	203	204	205	206	207	208	209	210	211	212	213	214	215	216	217	218	219	220	221	222	223	224	225	226	227	228	229	230	231	232	233	234	235	236	237	238	239	240	241	242	243	244	245	246	247	248	249	250	251	252	253	254	255	256	257	258	259	260	261	262	263	264	265	266	267	268	269	270	271	272	273	274	275	276	277	278	279	280	281	282	283	284	285	286	287	288	289	290	291	292	293	294	295	296	297	298	299	300	301	302	303	304	305	306	307	308	309	310	311	312	313	314	315	316	317	318	319	320	321	322	323	324	325	326	327	328	329	330	331	332	333	334	335	336	337	338	339	340	341	342	343	344	345	346	347	348	349	350	351	352	353	354	355	356	357	358	359	360	361	362	363	364	365	366	367	368	369	370	371	372	373	374	375	376	377	378	379	380	381	382	383	384	385	386	387	388	389	390	391	392	393	394	395	396	397	398	399	400	401	402	403	404	405	406	407	408	409	410	411	412	413	414	415	416	417	418	419	420	421	422	423	424	425	426	427	428	429	430	431	432	433	434	435	436	437	438	439	440	441	442	443	444	445	446	447	448	449	450	451	452	453	454	455	456	457	458	459	460	461	462	463	464	465	466	467	468	469	470	471	472	473	474	475	476	477	478	479	480	481	482	483	484	485	486	487	488	489	490	491	492	493	494	495	496	497	498	499	500	501	502	503	504	505	506	507	508	509	510	511	512	513	514	515	516	517	518	519	520	521	522	523	524	525	526	527	528	529	530	531	532	533	534	535	536	537	538	539	540	541	542	543	544	545	546	547	548	549	550	551	552	553	554	555	556	557	558	559	560	561	562	563	564	565	566	567	568	569	570	571	572	573	574	575	576	577	578	579	580	581	582	583	584	585	586	587	588	589	590	591	592	593	594	595	596	597	598	599	600	601	602	603	604	605	606	607	608	609	610	611	612	613	614	615	616	617	618	619	620	621	622	623	624	625	626	627	628	629	630	631	632	633	634	635	636	637	638	639	640	641	642	643	644	645	646	647	648	649	650	651	652	653	654	655	656	657	658	659	660	661	662	663	664	665	666	667	668	669	670	671	672	673	674	675	676	677	678	679	680	681	682	683	684	685	686	687	688	689	690	691	692	693	694	695	696	697	698	699	700	701	702	703	704	705	706	707	708	709	710	711	712	713	714	715	716	717	718	719	720	721	722	723	724	725	726	727	728	729	730	731	732	733	734	735	736	737	738	739	740	741	742	743	744	745	746	747	748	749	750	751	752	753	754	755	756	757	758	759	760	761	762	763	764	765	766	767	768	769	770	771	772