



UNIVERSITY OF CAMBRIDGE INTERNATIONAL EXAMINATIONS
General Certificate of Education Ordinary Level

COMBINED SCIENCE

5129/12

Paper 1 Multiple Choice

October/November 2012

1 hour

Additional Materials: Multiple Choice Answer Sheet
 Soft clean eraser
 Soft pencil (type B or HB is recommended)



READ THESE INSTRUCTIONS FIRST

Write in soft pencil.

Do not use staples, paper clips, highlighters, glue or correction fluid.

Write your name, Centre number and candidate number on the Answer Sheet in the spaces provided unless this has been done for you.

There are **forty** questions on this paper. Answer **all** questions. For each question there are four possible answers **A, B, C** and **D**.

Choose the **one** you consider correct and record your choice in **soft pencil** on the separate Answer Sheet.

Read the instructions on the Answer Sheet very carefully.

Each correct answer will score one mark. A mark will not be deducted for a wrong answer.

Any rough working should be done in this booklet.

A copy of the Periodic Table is printed on page 20.

This document consists of **16** printed pages.



- 1 A rule is used to measure the internal diameter of a pipe.

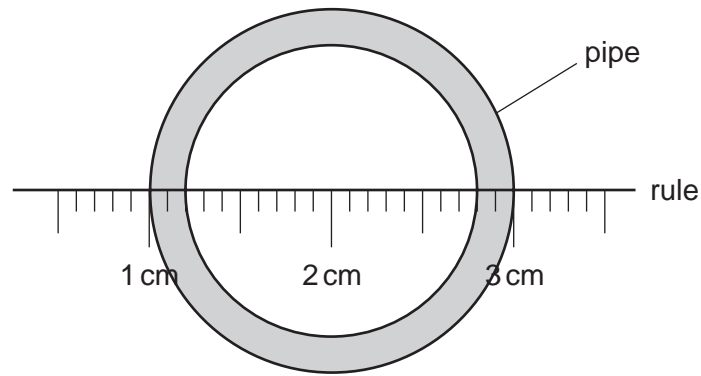

What is the internal diameter of the pipe?

- A** 1.6 cm **B** 1.8 cm **C** 2.0 cm **D** 2.6 cm
- 2 A car of mass 1800 kg is brought to a halt. The deceleration is 2 m/s^2 .
- What is the size of the force bringing the car to a halt?
- A** 900 N **B** 3600 N **C** 18 000 N **D** 36 000 N
- 3 What describes the density of a material?
- A** the amount of matter in the material
B the mass per unit volume of the material
C the pull of gravity on the material
D the volume per unit mass of the material
- 4 A cell will deliver 3000 J of energy to a 2 W electric motor before the cell is exhausted.
- How long will the motor run?
- A** 25 minutes
B 100 minutes
C 1500 minutes
D 6000 minutes

- 5 A liquid-in-glass laboratory thermometer and a liquid-in-glass clinical thermometer have several properties in common.

Which statement is **not** correct?

- A Both thermometers have a graduated scale.
 B Both thermometers have thin glass around the bulb.
 C Both thermometers have a constriction in the tube.
 D Both thermometers have a large bulb and a narrow bore.
- 6 What happens when a metal bar is heated?
- A The distance between the molecules increases, making the bar longer.
 B The molecules get larger, making the bar longer.
 C The molecules vibrate more quickly, making the bar denser.
 D The speed of the molecules increases, making the bar thinner.
- 7 Radio waves, visible light and X-rays are all part of the electromagnetic spectrum.

Which is the correct order of increasing wavelength?

| | shortest wavelength | —————> | longest wavelength |
|---|---------------------|---------------|--------------------|
| A | visible light | radio waves | X-rays |
| B | visible light | X-rays | radio waves |
| C | X-rays | radio waves | visible light |
| D | X-rays | visible light | radio waves |

- 8 An eye views an object O by reflection in a plane mirror.

Which is the correct ray diagram?

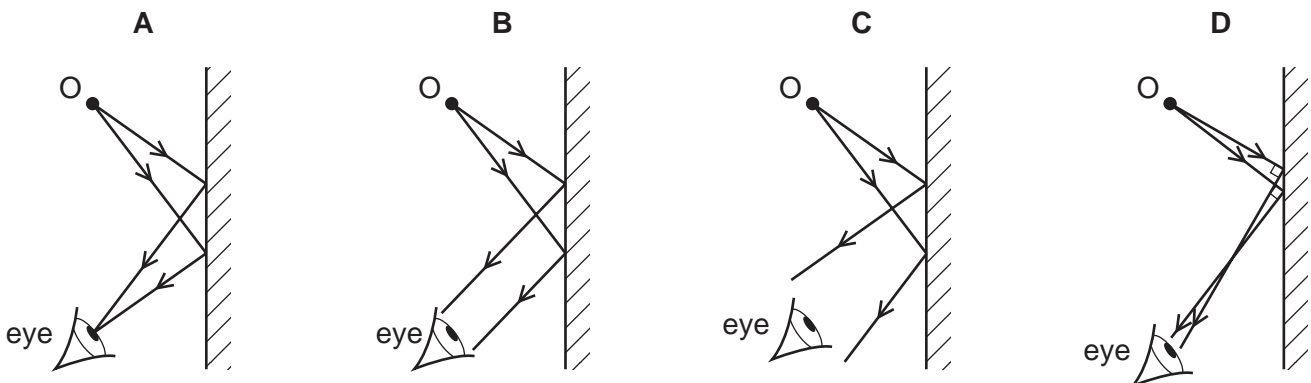

- 9 A small positive charge, P, is positioned close to a positively charged sphere.

What is the direction of the electrostatic force on P?

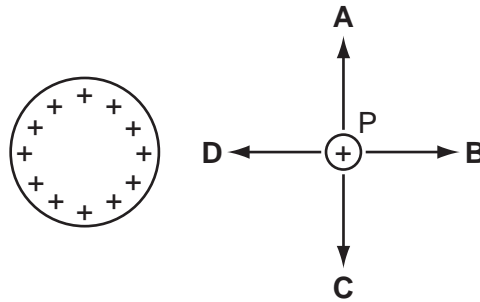

- 10 Diagram 1 shows two cells in series with two lamps X and Y. Both lamps light with normal brightness.

Diagram 2 shows a resistor in series with the same cells and lamps.

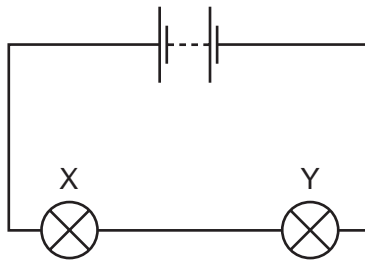

diagram 1

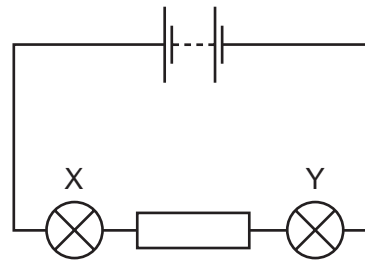

diagram 2

What is the brightness of lamp X and lamp Y in diagram 2?

| | lamp X | lamp Y |
|----------|----------------------|--------------------|
| A | brighter than normal | dimmer than normal |
| B | brighter than normal | normal |
| C | dimmer than normal | dimmer than normal |
| D | normal | dimmer than normal |

- 11 To determine whether a material is magnetic, a student should

- A** find out if it is a metal or a non-metal.
- B** find out if it is a conductor or an insulator.
- C** find out if it can be given an electric charge.
- D** find out if it affects the direction in which a compass needle points.

- 12 The primary coil of a simple iron-cored transformer is connected to an a.c. source and then to a d.c. source. The secondary coil is connected to an oscilloscope and the output of the transformer is observed for each source.

Which row correctly describes the output for a given source?

| | source | output |
|----------|--------|--------|
| A | a.c. | a.c. |
| B | a.c. | d.c. |
| C | d.c. | a.c. |
| D | d.c. | d.c. |

- 13 An atom has a nucleus surrounded by electrons.

What are the charges on the nucleus and on the whole atom?

| | charge on nucleus | charge on whole atom |
|----------|-------------------|----------------------|
| A | neutral | neutral |
| B | neutral | positive |
| C | positive | neutral |
| D | positive | positive |

- 14 Which statement about the particles in a liquid is **not** correct?

- A** They are arranged in regular patterns.
- B** They can escape from the liquid.
- C** They form a definite surface.
- D** Their speed increases as temperature increases.

- 15 What can be deduced from the symbol ${}^4_2\text{He}$?

- A** An atom of helium has two electrons.
- B** An atom of helium has two protons and four neutrons.
- C** Helium has a proton number of 4.
- D** Helium occurs as a diatomic molecule.

16 What is the best way of slowing down the reaction between magnesium and sulfuric acid?

- A adding a catalyst to the reactants
- B diluting the acid used in the reaction
- C stirring the reagents
- D using magnesium powder instead of ribbon

17 The table gives some properties of four substances.

Which substance is covalently bonded?

| | melting point /°C | boiling point /°C | electrical conductivity when liquid | electrical conductivity in aqueous solution |
|----------|----------------------|----------------------|---|--|
| A | 808 | 1465 | ✓ | ✓ |
| B | -114 | 78 | x | x |
| C | 64 | 748 | ✓ | ✓ |
| D | 327 | 1730 | ✓ | x |

18 The diagram shows the electronic structure of silane, SiH₄.

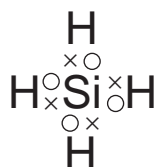

Which row shows the properties of silane?

| | conduction of electricity in the liquid state | melting point |
|----------|--|---------------|
| A | good | high |
| B | good | low |
| C | non-conductor | high |
| D | non-conductor | low |

19 Which mass of oxygen combines with 16 g of sulfur to form sulfur dioxide, SO₂?

- A** 4g
- B** 8g
- C** 16g
- D** 32g

20 Different solids were added to separate test-tubes of warm dilute sulfuric acid.

For which solid is the observation correct?

| | solid | observation |
|----------|------------------|---------------------------------------|
| A | ammonium sulfate | alkaline gas produced |
| B | copper | gas evolved ignited with a pop |
| C | magnesium oxide | solid dissolved with no effervescence |
| D | zinc carbonate | gas evolved relights glowing splint |

21 What is the order of reactivity of the halogens?

| | most reactive | → | least reactive |
|----------|---------------|----------|----------------|
| A | bromine | chlorine | iodine |
| B | chlorine | bromine | iodine |
| C | iodine | bromine | chlorine |
| D | iodine | chlorine | bromine |

22 Which metal does **not** react with dilute hydrochloric acid to give hydrogen?

- A** copper
- B** iron
- C** magnesium
- D** zinc

23 The boiling points of some elements are given in the table.

| element | boiling point/°C |
|----------|------------------|
| nitrogen | -196 |
| xenon | -108 |
| oxygen | -183 |

A mixture of nitrogen, xenon and oxygen at -200°C is allowed to warm up to -150°C .

Which elements are still in the liquid state at -150°C ?

- A** a mixture of nitrogen and oxygen
- B** a mixture of nitrogen and xenon
- C** nitrogen only
- D** xenon only

24 Which reaction takes place in the blast furnace?

- A $\text{FeCr}_2\text{O}_4 + 4\text{C} \rightarrow \text{Fe} + 2\text{Cr} + 4\text{CO}$
- B $3\text{Fe} + 4\text{H}_2\text{O} \rightarrow \text{Fe}_3\text{O}_4 + 4\text{H}_2$
- C $\text{SiO}_2 + \text{CaO} \rightarrow \text{CaSiO}_3$
- D $\text{SiO}_2 + 2\text{NaOH} \rightarrow \text{Na}_2\text{SiO}_3 + \text{H}_2\text{O}$

25 Ammonium sulfate, $(\text{NH}_4)_2\text{SO}_4$, is added to soil to provide an element that is important for plant growth.

What is this element?

- A hydrogen
- B nitrogen
- C oxygen
- D sulfur

26 X reacts with steam to form Y.

Y can be oxidised to Z.



If Z is propanoic acid, what would be the formula of X?

- A C_2H_4
- B C_2H_6
- C C_3H_6
- D C_3H_8

27 Propene is an unsaturated hydrocarbon. Its structure is shown.

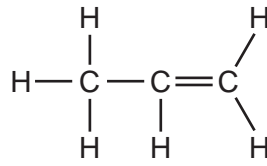

What is produced when propene reacts with bromine?

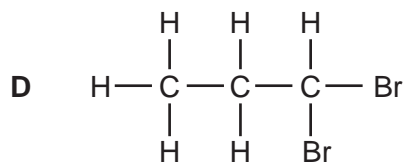
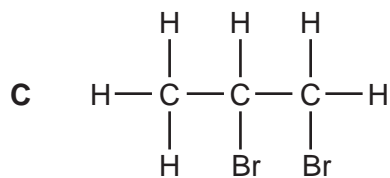
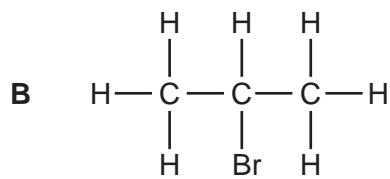
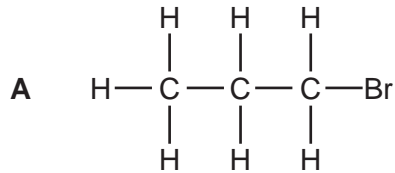

28 The diagram shows a typical plant cell after being placed into a concentrated salt solution for ten minutes.

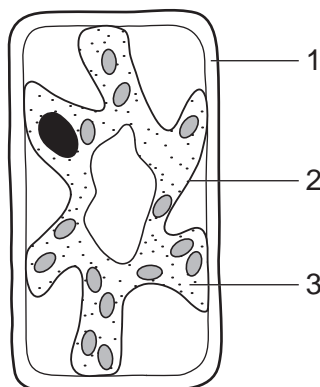

Which numbered structures are partially permeable?

- A** 1 and 2 only **B** 1 and 3 only **C** 1 only **D** 2 only

29 The following reaction occurs in the human alimentary canal.

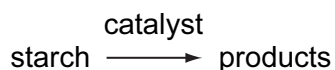

What are the catalyst and the product?

| | catalyst | product |
|----------|----------|------------|
| A | acid | glucose |
| B | alkali | energy |
| C | amylase | maltose |
| D | bile | amino acid |

30 The graph shows the effect of different colours of light on the rate of oxygen production by green plants.

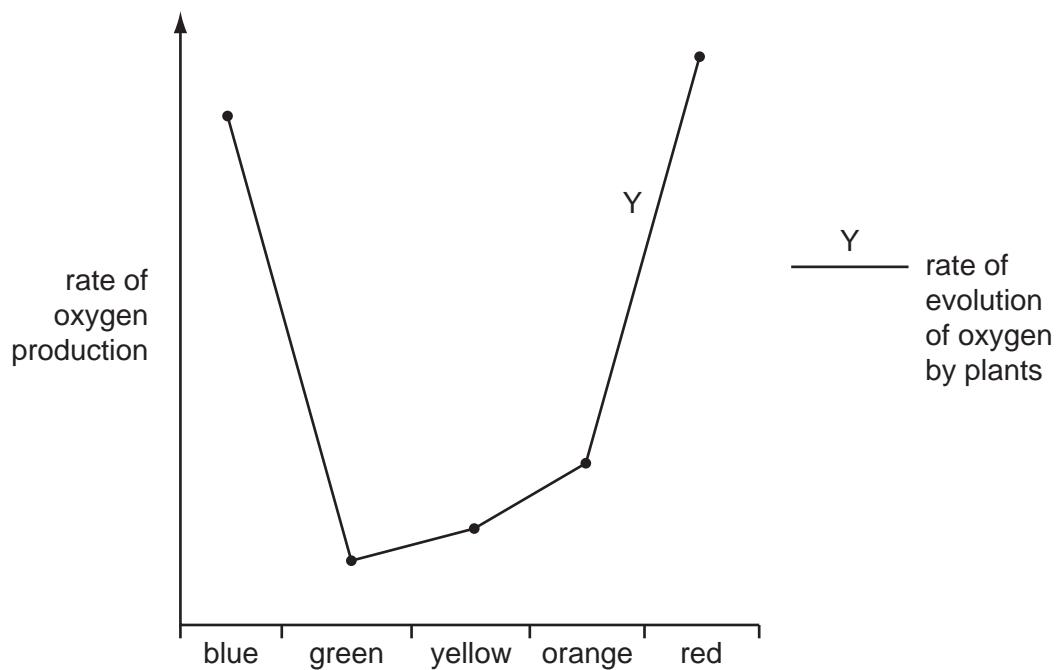

What can be deduced from the graph?

- A** Photosynthesis is least active in green light.
- B** Photosynthesis is most active in green light.
- C** Respiration is least active in green light.
- D** Respiration is most active in green light.

31 The diagram shows the composition of four foods.

Which food will provide the most energy per gram?

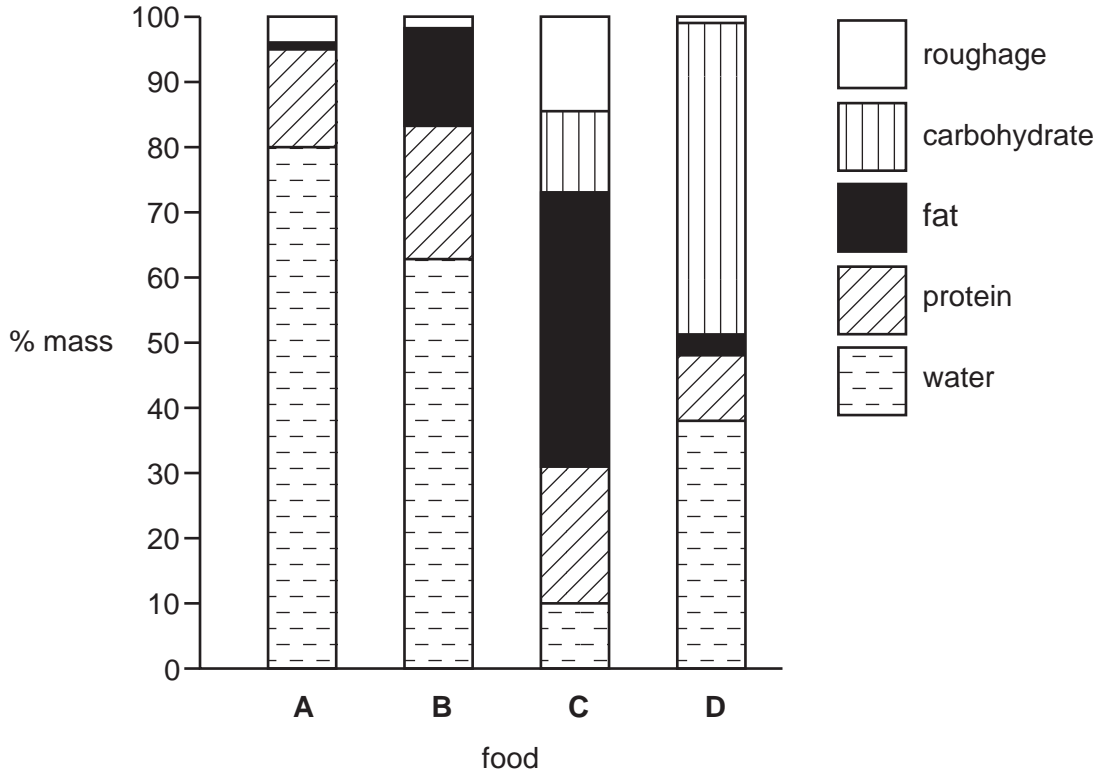

32 How do these substances enter a plant's root hairs?

| | nitrate | oxygen | water |
|----------|------------------|------------------|------------------|
| A | active transport | diffusion | osmosis |
| B | diffusion | osmosis | active transport |
| C | osmosis | active transport | diffusion |
| D | osmosis | diffusion | active transport |

33 The table shows substances that pass between capillaries and tissues in a part of the body.

| substance | into the capillaries from the tissues | out of the capillaries into the tissues |
|----------------|--|--|
| oxygen | | ✓ |
| carbon dioxide | ✓ | |
| amino acids | | ✓ |
| urea | ✓ | |

In which part of the body are these capillaries?

- A between the alveoli
- B in the kidney
- C in the liver
- D in the villi

34 The apparatus shown is used to investigate gas exchange during breathing.

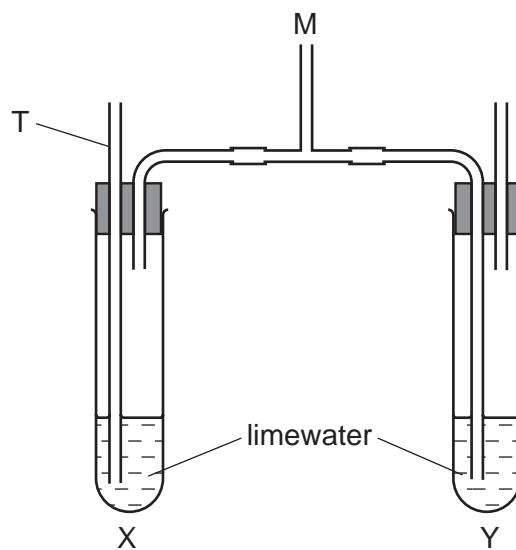

What would occur when a person breathes gently in and out several times through tube M?

- A The solutions in X and Y both turn cloudy.
- B The solution in X remains clear, but that in Y turns cloudy.
- C The solution in X turns cloudy, but that in Y remains clear.
- D The solution in X is forced out through the tube T.

35 Which statement best describes changes in parts of the eye when starting focus on a near object?

- A Ciliary muscles contract, suspensory ligaments loosen and the lens becomes more rounded.
- B Ciliary muscles contract, suspensory ligaments tighten and the lens becomes flatter.
- C Ciliary muscles relax, suspensory ligaments loosen and the lens becomes more rounded.
- D Ciliary muscles relax, suspensory ligaments tighten and the lens becomes flatter.

36 Which descriptions of drugs are correct?

| | have side effects | are broken down by the liver |
|----------|-------------------|------------------------------|
| A | x | x |
| B | x | ✓ |
| C | ✓ | x |
| D | ✓ | ✓ |

37 The diagram shows part of the food web.

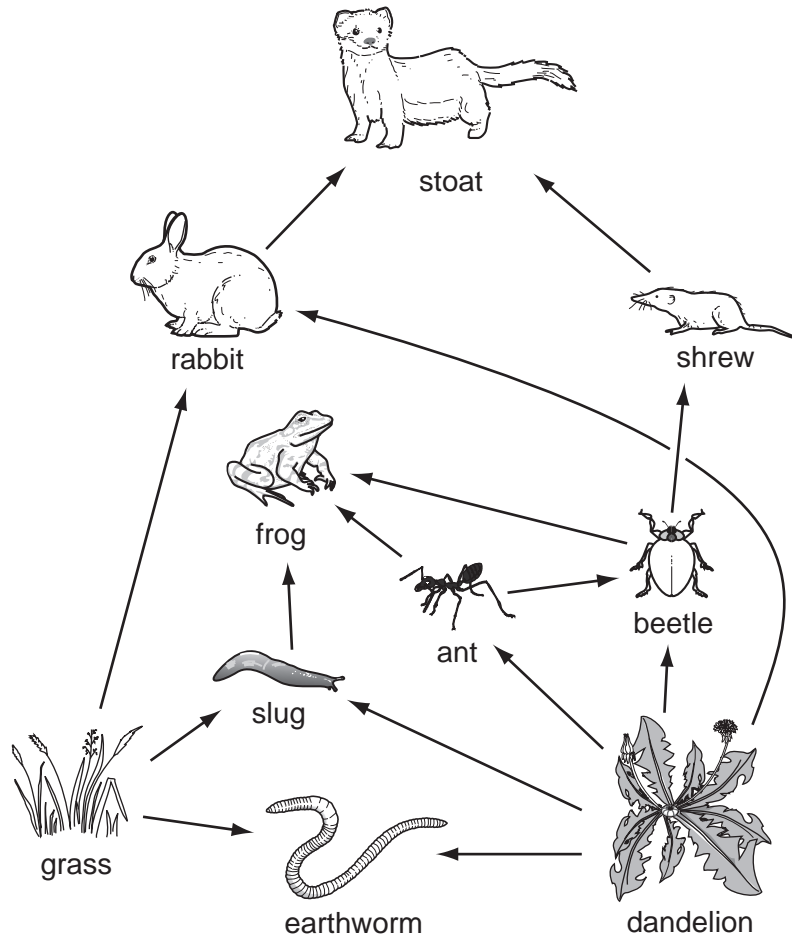

Which organism can properly be described by **only one** of the terms producer, consumer, herbivore and carnivore?

- A ant
- B dandelion
- C frog
- D stoat

38 What increases in the long term as a result of tropical deforestation?

- A cloud cover
- B humidity
- C soil erosion
- D soil fertility

39 What is always true of the offspring from asexual reproduction in plants?

- A a new variety
- B more resistant to disease
- C same flower shape
- D same size

40 The diagram shows the male reproductive system.

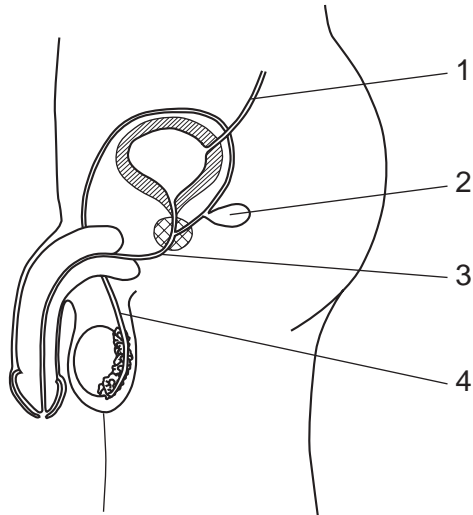

How could surgical contraception be carried out?

- A cutting and tying tube 1
- B cutting and tying tube 3
- C cutting and tying tube 4
- D removing gland 2

DATA SHEET
The Periodic Table of the Elements

| | | Group | | | | | | | | | | | | |
|-----------------------------------|------------------------------------|-------------------------------------|--|-------------------------------------|--------------------------------------|-------------------------------------|-------------------------------------|--------------------------------------|-------------------------------------|---------------------------------------|---------------------------------------|------------------------------------|--|---------------------------------------|
| I | II | III | IV | V | VI | VII | 0 | | | | | | | |
| 7 Li Lithium 3 | 9 Be Beryllium 4 | 1 H Hydrogen 1 | 11 B Boron 5 | 12 C Carbon 6 | 14 N Nitrogen 7 | 16 O Oxygen 8 | 19 F Fluorine 9 | 20 Ne Neon 10 | | | | | | |
| 23 Na Sodium 11 | 24 Mg Magnesium 12 | 27 Al Aluminium 13 | 28 Si Silicon 14 | 31 P Phosphorus 15 | 32 S Sulfur 16 | 35.5 Cl Chlorine 17 | 40 Ar Argon 18 | | | | | | | |
| 39 K Potassium 19 | 40 Ca Calcium 20 | 56 Fe Iron 26 | 55 Mn Manganese 25 | 59 Co Cobalt 27 | 59 Ni Nickel 28 | 64 Cu Copper 29 | 65 Zn Zinc 30 | 70 Ga Gallium 31 | 73 Ge Germanium 32 | 75 As Arsenic 33 | 79 Se Selenium 34 | 84 Kr Krypton 36 | | |
| 85 Rb Rubidium 37 | 88 Sr Strontium 38 | 101 Ru Ruthenium 44 | 101 Tc Technetium 43 | 103 Rh Rhodium 45 | 106 Pd Palladium 46 | 108 Ag Silver 47 | 112 Cd Cadmium 48 | 115 In Indium 49 | 119 Sn Tin 50 | 122 Sb Antimony 51 | 128 Te Tellurium 52 | 131 Xe Xenon 54 | | |
| 133 Cs Caesium 55 | 137 Ba Barium 56 | 186 Os Osmium 76 | 184 W Tungsten 74 | 192 Ir Iridium 77 | 195 Pt Platinum 78 | 197 Au Gold 79 | 201 Hg Mercury 80 | 204 Tl Thallium 81 | 207 Pb Lead 82 | 209 Bi Bismuth 83 | 210 Po Polonium 84 | 210 Rn Radon 86 | | |
| 87 Fr Francium | 88 Ra Radium | 226 Ac Actinium | | | | | | | | | | | | |
| | | 140 Ce Cerium 58 | 141 Pr Praseodymium 59 | 144 Nd Neodymium 60 | 146 Pm Promethium 61 | 150 Sm Samarium 62 | 152 Eu Europium 63 | 157 Gd Gadolinium 64 | 159 Tb Terbium 65 | 162 Dy Dysprosium 66 | 165 Ho Holmium 67 | 169 Er Erbium 68 | 173 Yb Ytterbium 70 | 175 Lu Lutetium 71 |
| | | 232 Th Thorium 90 | 231 Pa Protactinium 91 | 238 U Uranium 92 | 237 Np Neptunium 93 | 244 Pu Plutonium 94 | 247 Am Americium 95 | 251 Cm Curium 96 | 259 Bk Berkelium 97 | 261 Cf Californium 98 | 269 Es Einsteinium 99 | 277 Fm Fermium 100 | 289 Md Mendelevium 101 | 288 Lr Lawrencium 103 |

*58-71 Lanthanoid series
†90-103 Actinoid series

Key
a **X** a = relative atomic mass
b **X** b = atomic symbol
c **X** c = proton (atomic) number

The volume of one mole of any gas is 24 dm³ at room temperature and pressure (r.t.p.).

Permission to reproduce items where third-party owned material protected by copyright is included has been sought and cleared where possible. Every reasonable effort has been made by the publisher (UCLES) to trace copyright holders, but if any items requiring clearance have unwittingly been included, the publisher will be pleased to make amends at the earliest possible opportunity.

University of Cambridge International Examinations is part of the Cambridge Assessment Group. Cambridge Assessment is the brand name of University of Cambridge Local Examinations Syndicate (UCLES), which is itself a department of the University of Cambridge.