



UNIVERSITY OF CAMBRIDGE INTERNATIONAL EXAMINATIONS
General Certificate of Education Ordinary Level

CANDIDATE
NAME

CENTRE
NUMBER

--	--	--	--	--	--

CANDIDATE
NUMBER

--	--	--	--	--



COMBINED SCIENCE

5129/21

Paper 2

October/November 2013

2 hours 15 minutes

Candidates answer on the Question Paper.

No Additional Materials are required.

READ THESE INSTRUCTIONS FIRST

Write your Centre number, candidate number and name on all the work you hand in.

Write in dark blue or black pen.

You may use a soft pencil for any diagrams, graphs or rough working.

Do not use staples, paper clips, highlighters, glue or correction fluid.

DO NOT WRITE IN ANY BARCODES.

Answer **all** questions.

A copy of the Periodic Table is printed on page 24.

Electronic calculators may be used.

You may lose marks if you do not show your working or if you do not use appropriate units.

At the end of the examination, fasten all your work securely together.

The number of marks is given in brackets [] at the end of each question or part question.

This document consists of **22** printed pages and **2** blank pages.



1 Use words from the list to complete the sentences below.

- | | | | |
|--------------------|--------------|--------------------|------------------|
| amino acids | bile | egestion | excretion |
| expired air | fat | glucose | kidneys |
| liver | lungs | respiration | urine |

Each word may be used once, more than once or not at all.

Urea is formed from that the body no longer needs.

The formation of urea takes place in the

Urea is passed out of the body in

This is an example of

[4]

- 2 Fig. 2.1 gives information about some of the elements in Group I of the Periodic Table.

element	symbol	proton number
lithium	Li	3
sodium	Na	11
potassium	K	19
rubidium	Rb	37
caesium	Cs	55

Fig. 2.1

- (a) State the name given to the elements in Group I.

.....[1]

- (b) State the trend shown by the melting points as the proton number increases.

.....[1]

- (c) All the elements in Group I react with water to produce a metal hydroxide and hydrogen.

State the test for hydrogen.

test.....

result.....

.....[2]

- (d) Rubidium reacts with chlorine to produce rubidium chloride.

- (i) Construct an equation for this reaction.

.....[1]

- (ii) State the type of bonding present in rubidium chloride.

.....[1]

3 A battery supplies energy to the electric motor of a toy car.

(a) When the car is moving at constant speed, the current in the motor is 0.80 A.

Calculate the charge flowing through the motor in 10 minutes and state the unit.

charge = unit [3]

(b) Complete the following sentence about energy changes.

Some of the electrical energy is converted into sound energy and thermal energy.

The rest is converted into energy. [1]

(c) The toy car moves 4.8 m in 1.5 s.

Calculate its average speed.

speed = m/s [2]

- 4 Fig. 4.1 shows a ray of light incident on one face of a parallel-sided glass block. The angle of incidence is 22° and the angle of refraction is 15° .

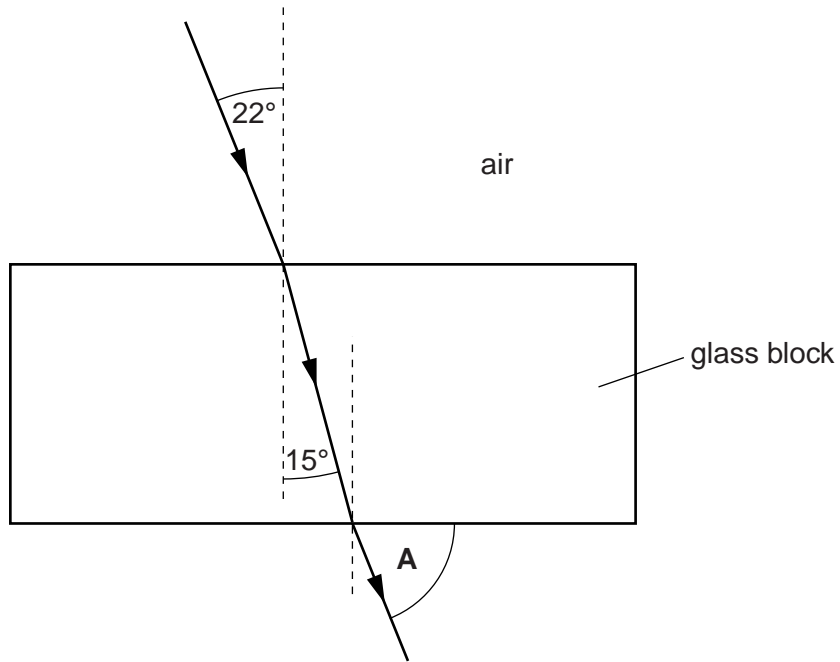

Fig. 4.1

The ray passes through the glass and emerges into air.

- (a) Calculate the refractive index of the glass.

refractive index = [2]

- (b) State the value of the angle **A** shown in Fig. 4.1.

angle = $^\circ$ [1]

- (c) Light travels at different speeds in different materials.

State the speed of light in a vacuum.

speed = m/s [1]

5 Fig. 5.1 shows two food chains **A** and **B**.

The organisms in the food chain are not drawn to the same scale.

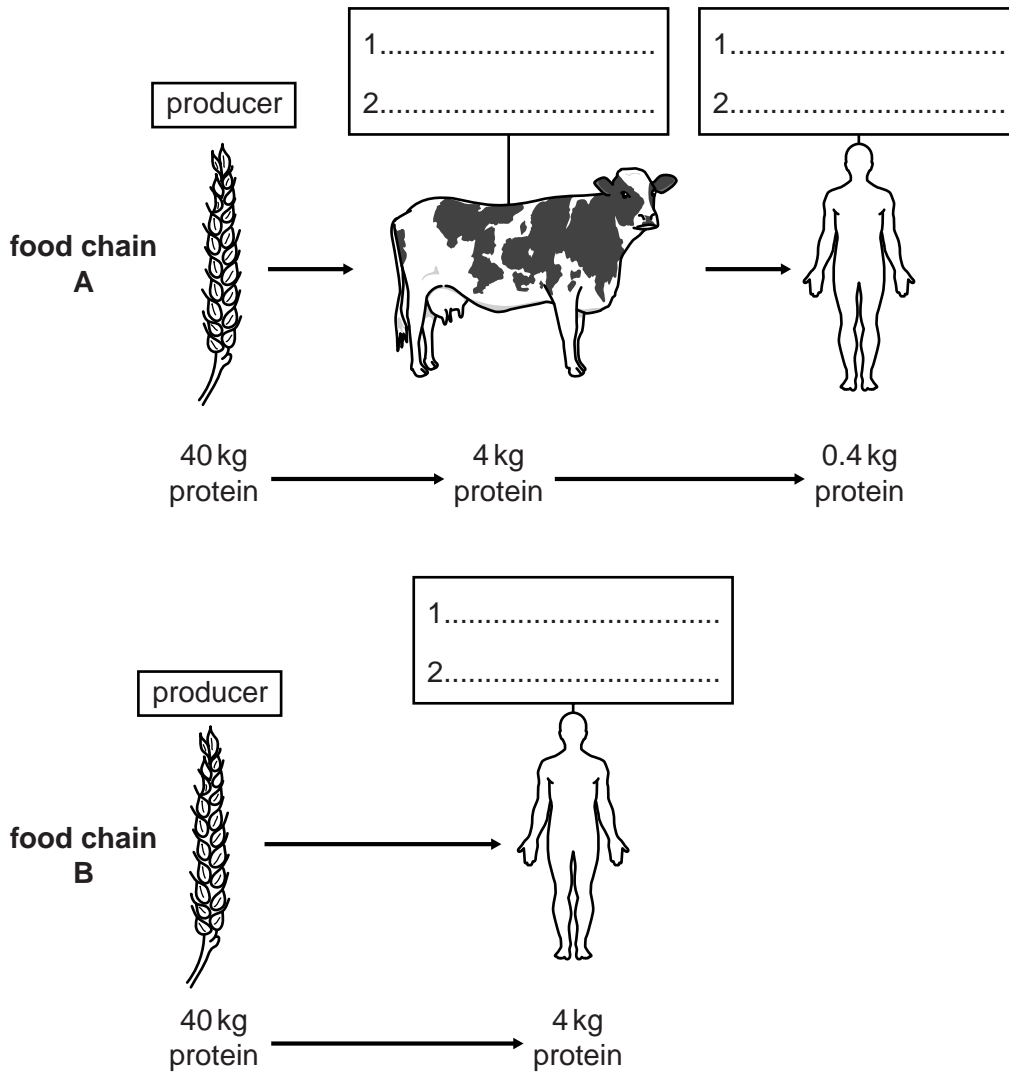

Fig. 5.1

(a) The list below gives roles of organisms in a food chain.

In each box on Fig. 5.1, write two terms **from the list** below that describe the roles of the organisms in each food chain.

Each term may be used once, more than once or not at all.

- carnivore
- decomposer
- herbivore
- primary consumer
- producer
- secondary consumer
- tertiary consumer

[6]

(b) Fig. 5.1 shows how an initial mass of protein changes at each stage in each food chain.

Calculate the percentage of the protein in the producer that becomes protein in the human in each food chain.

(i) food chain **A**

percentage =%

(ii) food chain **B**

percentage =%
[2]

(c) Some people think that cereals are a better food source than meat for humans.

State and explain, by referring to part (b), what evidence there is from food chains **A** and **B** to support this view.

.....
.....
.....
.....[2]

- 6 (a) Hydrogen sulfide contains sulfur and hydrogen and has the formula H_2S .

Sulfur is in Group VI of the Periodic Table.

Complete Fig. 6.1 to show the arrangement of the outer shell electrons in a molecule of hydrogen sulfide.

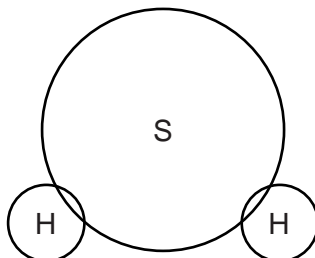
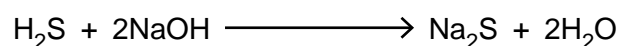

Fig. 6.1

[2]

- (b) Hydrogen sulfide reacts with sodium hydroxide to form sodium sulfide and water.

The equation for the reaction is



The relative molecular mass, M_r , of sodium hydroxide is 40.
 [A_r : S, 32; Na, 23; O, 16; H, 1]

Complete the following sentences.

80 g of sodium hydroxide reacts with g of hydrogen sulfide and produces g of sodium sulfide.

8 g of sodium hydroxide produces g of sodium sulfide.

2 g of sodium hydroxide produces g of sodium sulfide.

[4]

7 The following is a list of substances.

ammonium chloride

calcium carbonate

potassium hydroxide

sodium nitrate

sulfur dioxide

For
Examiner's
Use

Use the list to complete the following sentences.

Each substance may be used once, more than once or not at all.

(a) Two substances that react together to produce ammonia are

..... and [2]

(b) The substance that reacts with dilute hydrochloric acid to produce

a salt and water **only** is [1]

(c) The substance that turns Universal Indicator red is

..... [1]

(d) The substance used to reduce acidity in soil is

..... [1]

8 A paint gun is used to paint a metal surface, as shown in Fig. 8.1.

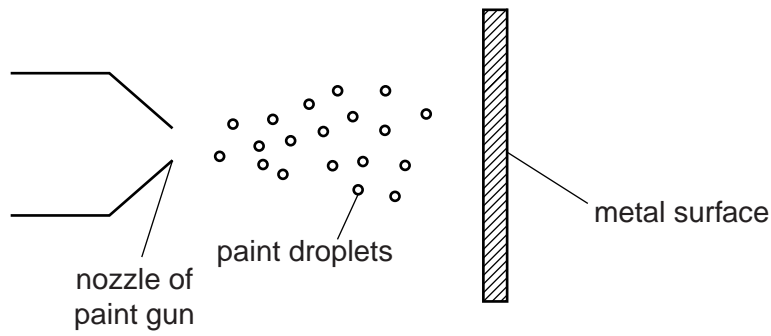

Fig. 8.1

All the paint droplets are given a positive charge as they leave the nozzle.

The metal surface is given a negative charge.

Suggest why

all the droplets are attracted to the metal plate,

.....
..... [1]

after leaving the nozzle, the droplets move apart.

.....
..... [1]

9 Fig. 9.1 shows how the voltage output of a simple a.c. generator changes with time.

For
Examiner's
Use

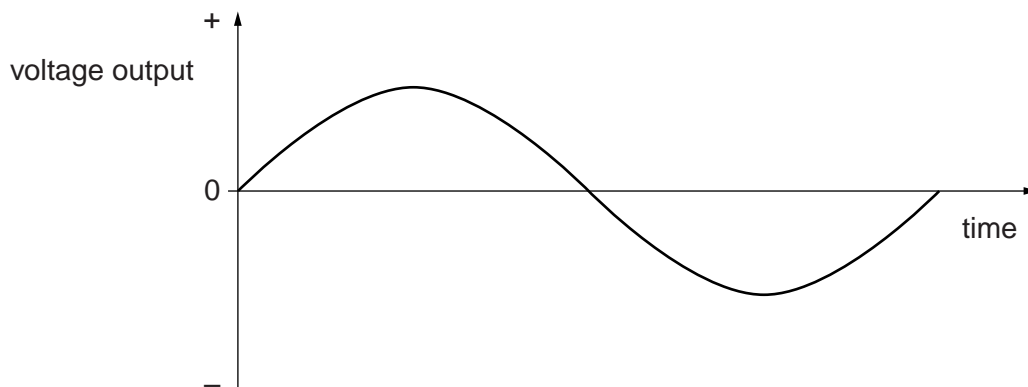

Fig. 9.1

(a) The coil of the a.c. generator is rotated at twice the original speed.

State the difference, if any, this would make to

(i) the maximum of the voltage output,

..... [1]

(ii) the frequency of the voltage output.

..... [1]

(b) The output of the generator is connected to a transformer.

State and explain why a transformer will **not** work if it is connected to a d.c. supply, rather than an a.c. supply.

.....

 [2]

10 Fig. 10.1 shows an outline of the carbon cycle.

The processes in the cycle are represented by letters.

For
Examiner's
Use

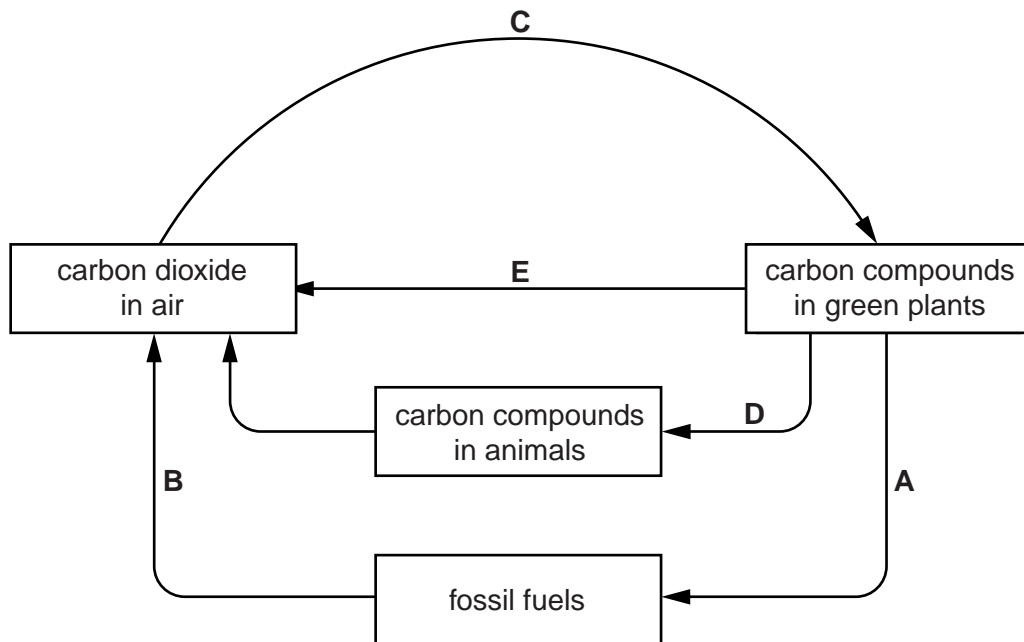

Fig. 10.1

(a) Complete Table 10.1 by naming the process represented by each letter.

An example has been done for you.

Table 10.1

letter	name of process
A	fossilisation
B	
C	
D	
E	

[4]

(b) (i) Complete the word equation for process E.

..... + → + water [3]

(ii) Put a tick in the box by the correct period to show when process E takes place during a 24-hour period.

night and day	
day-time only	
night-time only	

[1]

11 An element X exists as two isotopes, ^{69}X and ^{71}X .

(a) Complete Table. 11.1 for a neutral atom of each isotope.

Table. 11.1

isotope	number of protons	number of neutrons	number of electrons
^{69}X			31
^{71}X	31	40	

[3]

(b) Explain why the chemical properties of the two isotopes are the same.

.....

 [1]

(c) Use the Periodic Table to identify element X.

..... [1]

12 A student carries out an experiment using an elastic band to measure its extension for different loads.

For
Examiner's
Use

(a) In the space below, draw a **labelled** diagram of the apparatus that may be used to obtain an extension-load graph for this elastic band.

[2]

Fig. 12.1 shows an extension-load graph for this elastic band.

Some points have been plotted on the graph.

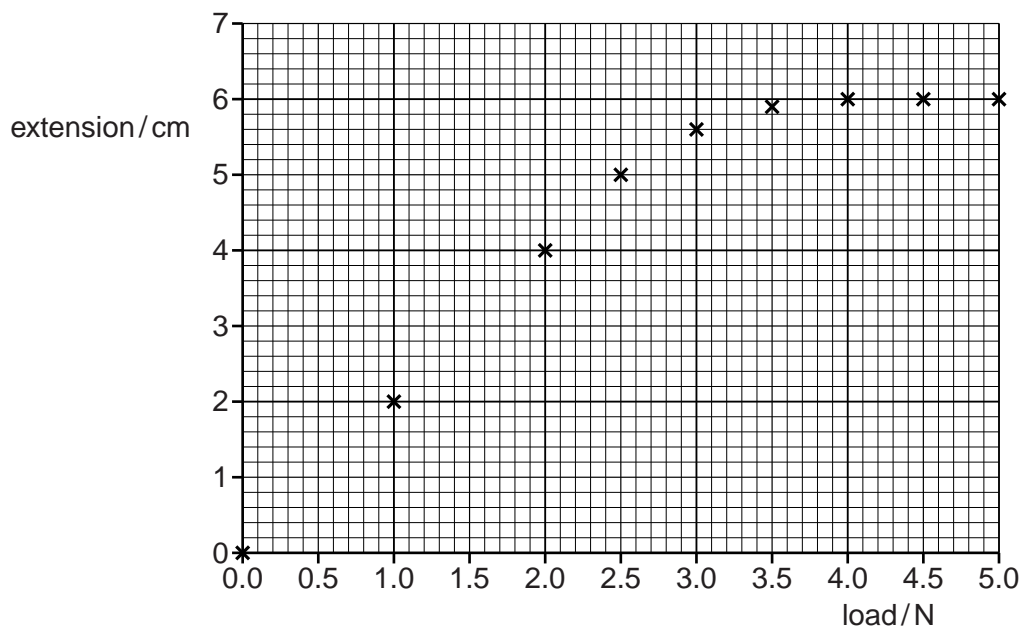

Fig. 12.1

(b) On Fig. 12.1, draw a line of best fit for the points. [2]

(c) With no load on the elastic band, its length is 8.0 cm.

Use Fig. 12.1 to determine the length of the elastic band for a load of 2.0 N.

length = cm [1]

- 13 Fig. 13.1 shows a series circuit containing a 1.5V cell and three resistors.

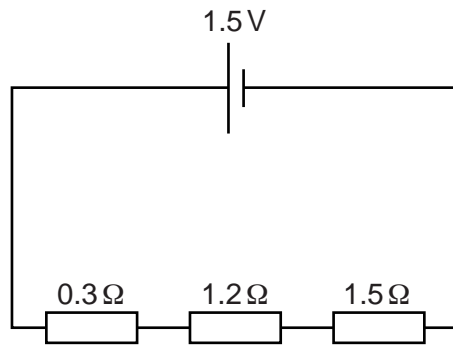

Fig. 13.1

The resistors have values of 0.3Ω , 1.2Ω and 1.5Ω .

- (a) Calculate the combined resistance of the resistors.

resistance = Ω [1]

- (b) Calculate the current in the circuit.

current = A [2]

14 A student carries out an experiment using a metal ball and a metal ring, as shown in Fig. 14.1.

For
Examiner's
Use

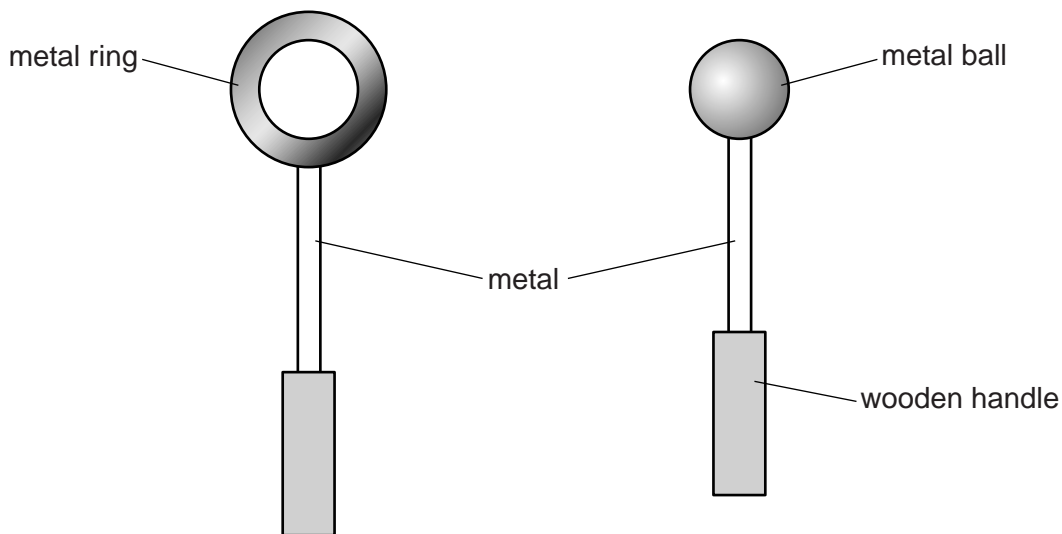

Fig. 14.1

The metal ball will just pass through the metal ring when the ball and ring are at room temperature.

(a) Explain why the metal ball will no longer pass through the metal ring when

(i) the metal ball is heated and the ring remains at room temperature,

..... [1]

(ii) the metal ring is cooled and the ball remains at room temperature.

..... [1]

(b) Suggest why the handles are made of wood.

.....
 [1]

- 15 Fig. 15.1 shows that ethanol may be made from glucose or from ethene.

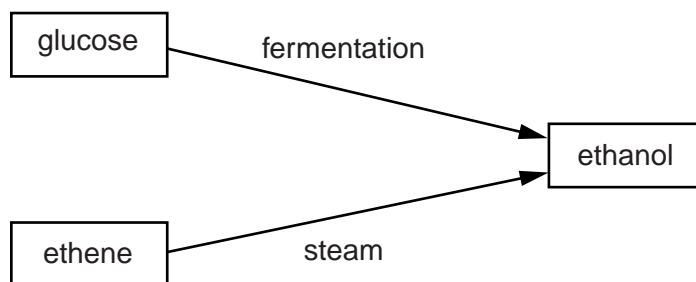

Fig. 15.1

- (a) (i) Describe the conditions for the fermentation of glucose to form ethanol.

.....

 [3]

- (ii) Balance the equation for the fermentation reaction.

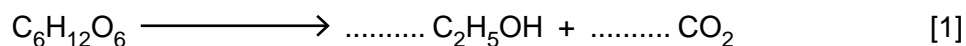

- (b) State the type of reaction ethene undergoes when it reacts with steam.

..... [1]

- (c) Ethene is an unsaturated hydrocarbon.

Ethane is a saturated hydrocarbon.

- (i) State how the structure of ethene differs from the structure of ethane.

..... [1]

- (ii) State how the colour of aqueous bromine changes when it is added to ethene.

..... [1]

16 Fig. 16.1 shows a method of lifting water from a river.

The bucket is raised from the river when a person pushes down on the end of the lever.

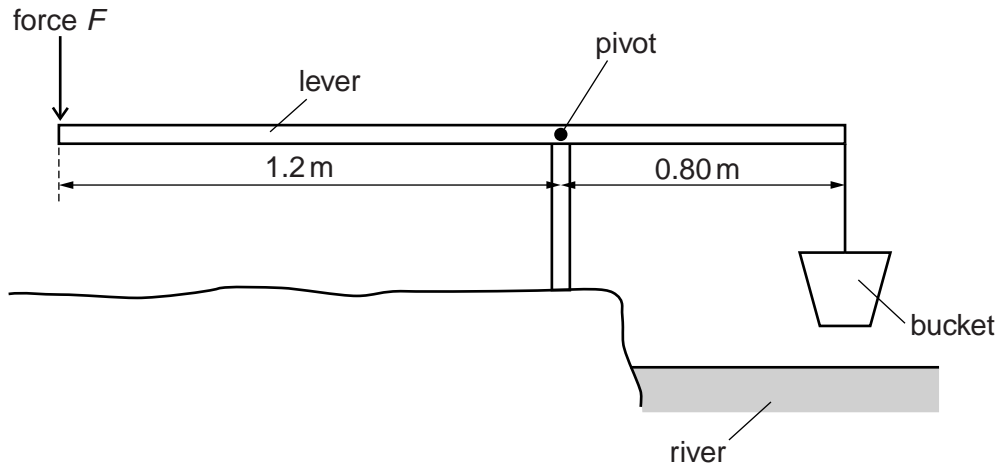

Fig. 16.1

The bucket and its contents weigh 60 N. The bucket is suspended 0.80 m from the pivot.

A man pushes down on the lever with a vertical force F , at a point a distance of 1.2 m from the pivot.

(a) Calculate the force that the man exerts on the end of the lever to keep it horizontal.

force = N [2]

(b) When lifting the bucket and water, the man does 150 J of work in 1.25 s.

Calculate the useful power developed by the man in lifting the bucket and water.

power = W [2]

17 (a) Describe the similarities between aerobic respiration and combustion.

.....
.....
.....
.....
..... [3]

(b) Name one air pollutant and state the effect of this pollutant on the environment.

pollutant
effect on the environment
..... [2]

18 Fig. 18.1 shows a diagram of the alimentary canal.

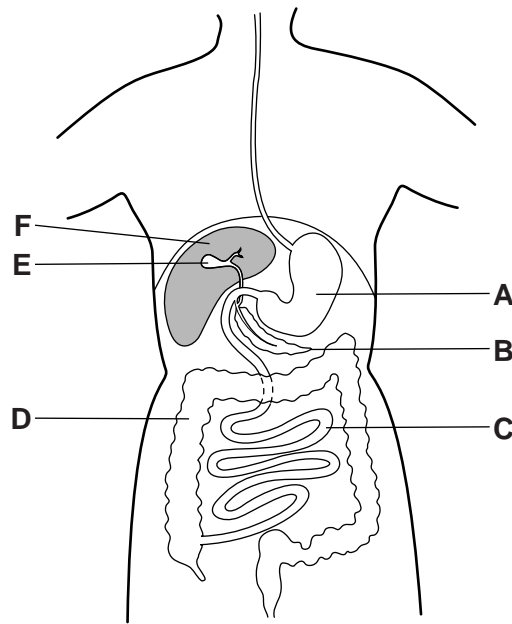

Fig. 18.1

(a) Use the letters on Fig. 18.1 to identify

- (i) the ileum,
- (ii) the stomach,
- (iii) the pancreas.

[3]

(b) State a function for each of the following parts of the digestive system.

stomach

.....

pancreas.....

.....

ileum

.....

colon

.....

[4]

(c) (i) On Fig. 18.1, mark with the letter X the organ where bile is made. [1]

(ii) Explain how bile makes digestion more efficient.

.....
.....
.....
.....
.....[3]

For
Examiner's
Use

19 A nucleus of barium (Ba) contains 56 protons and 81 neutrons.
It is represented by ${}^A_Z\text{Ba}$.

State the value of

(a) A, [1]

(b) Z. [1]

BLANK PAGE

Permission to reproduce items where third-party owned material protected by copyright is included has been sought and cleared where possible. Every reasonable effort has been made by the publisher (UCLES) to trace copyright holders, but if any items requiring clearance have unwittingly been included, the publisher will be pleased to make amends at the earliest possible opportunity.

University of Cambridge International Examinations is part of the Cambridge Assessment Group. Cambridge Assessment is the brand name of University of Cambridge Local Examinations Syndicate (UCLES), which is itself a department of the University of Cambridge.

