

CAMBRIDGE INTERNATIONAL EXAMINATIONS

Cambridge International Advanced Level

MARK SCHEME for the October/November 2014 series

9705 DESIGN AND TECHNOLOGY

9705/32

Paper 3, maximum raw mark 120

This mark scheme is published as an aid to teachers and candidates, to indicate the requirements of the examination. It shows the basis on which Examiners were instructed to award marks. It does not indicate the details of the discussions that took place at an Examiners' meeting before marking began, which would have considered the acceptability of alternative answers.

Mark schemes should be read in conjunction with the question paper and the Principal Examiner Report for Teachers.

Cambridge will not enter into discussions about these mark schemes.

Cambridge is publishing the mark schemes for the October/November 2014 series for most Cambridge IGCSE[®], Cambridge International A and AS Level components and some Cambridge O Level components.

® IGCSE is the registered trademark of Cambridge International Examinations.

Page 2	Mark Scheme	Syllabus	Paper
	Cambridge International A Level – October/November 2014	9705	32

Section A

Part A – Product Design

- 1 (a) suitable material including:
- PVC
 - Mild steel (plated)
 - Aluminium
 - ABS
 - Acrylic
 - Appropriate hardwood
- [1]
- reasons including:
- Easy to turn/mould
 - Even dome shape created
 - Suitable for outdoor use
 - Aesthetic qualities
 - Lightweight, easy to form
- 2 × 1 [2]
- (b) quality of description:
- fully detailed
 - some detail
- 3 – 7
0 – 2
- quality of sketches
- up to 2 [9]
- (c) explanation could include:
- change in process;
 - change in materials;
 - use of jigs, formers, moulds;
 - simplification of design.
- quality of explanation:
- logical, structured
 - limited detail
 - quality of sketches
- 4 – 6
0 – 3
up to 2 [8]
- [Total: 20]**

Page 3	Mark Scheme	Syllabus	Paper
	Cambridge International A Level – October/November 2014	9705	32

2 Discussion could include:

- anthropometrics/ergonomics
- market research
- marketing/advertising
- legislation and standards
- inclusion

Examination of issues

- wide range of relevant issues 5 – 9
- limited range 0 – 4 [9]

Quality of explanation

- logical, structured 4 – 7
- limited detail 0 – 3 [7]

Supporting examples / evidence

- User testing
- Specific anthropometric examples
- questionnaires
- specific promotion [4]

[Total: 20]

3 (a) description of process

- fully detailed 3 – 5
- some detail 0 – 2
- quality of sketches up to 2 (7 × 2) [14]

(b) laminating

- little wastage
- strong, can keep shape
- easily repeated

Extrusion

- no wastage
- exceptionally quick/consistent standard of section
- grain structure enhanced

Rotational moulding

- large hollow shape
- excellent finish
- minimal wastage – exact amounts used
- quick one piece production 3 × 2 [6]

[Total: 20]

Page 4	Mark Scheme	Syllabus	Paper
	Cambridge International A Level – October/November 2014	9705	32

Part B – Practical Design

4 Explanation/products/materials could be:

toughness – (resist sudden impact) – spring (tempered steel) hammer shaft (hickory, ash)

elasticity – (returns to original shape after extension) – thread/fabrics (nylon) sweater/sports shirt, elastic band or inner tube (rubber)

thermal conductivity – (ability to conduct heat) heat sink (copper, aluminium) soldering iron tip (copper) cooking pans (stainless steel, copper)

corrosion resistance – (resistance to degradation when placed in an outdoor environment or in contact with certain chemicals) bench (teak, cedar) litter bin (aluminium, polypropylene, PVC)

Accept any other appropriate product or application

Quality of explanation: (must include specific product/material for full marks)

– logical, structured

3 – 4

– limited detail

0 – 2 (4 × 5) [20]

[Total: 20]

5 Details of manufacture

2 × 5 [10]

Specific materials given

[2]

Cost and time factors considered

[3]

Methods compared and contrasted

[5]

[Total: 20]

6 (a) **Photodiode** – a type of photo-detector capable of converting light into either current or voltage depending upon the mode of operation e.g. solar cell.



Thermistor – is a type of resistor whose resistance varies significantly with temperature, e.g. aquarium sensor.



Relay – is an electrically operated switch often using an electromagnet to operate a switching mechanism mechanically e.g. switching on a 240v pump.

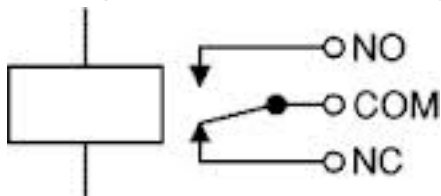

3 × 3 [9]

Page 5	Mark Scheme	Syllabus	Paper
	Cambridge International A Level – October/November 2014	9705	32

- (b) (i) When probes dry, voltage into pin 3 high, positive output, red LED on.
 When probes wet, input into pin 3 lower than pin 2, negative output, green LED on.
 Variable resistor sets sensitivity, 220 Ω resistor protects LEDs

Quality of explanation:

- full detail of operation of circuit
- limited detail

3 – 5

0 – 2 [5]

- (ii) Appropriate casing showing probes, switch(es), battery cover
 Quality of communication

4

2 [6]

[Total: 20]

Page 6	Mark Scheme	Syllabus	Paper
	Cambridge International A Level – October/November 2014	9705	32

Part C – Graphic Products

7 Discussion could include:

- explore ideas
- show clients
- test 3D views
- scale/proportion
- trial working/assembly systems
- allow ‘hands on’ analysis/evaluation

Examination of issues

- wide range of relevant issues 5 – 9
- limited range 0 – 4

Quality of explanation

- logical, structured 4 – 7
- limited detail, 0 – 3

Supporting examples/evidence

- sketching/exploring
- model mechanisms/
- scaled proposals [4]

[Total: 20]

8 (a) suitable material e.g.:

- starch based/ plant based biodegradable card
- poly coated paperboard
- food grade ivory board
- 1 mark for card, 2 marks for specific card

2

Reasons

- easy to cut/fold
- accept print
- withstand spillage
- two appropriate reasons 2 [4]

(b) quality of description:

- fully detailed including presse form/print 10 – 14
- some detail, could include one off production 5 – 9
- limited detail, basic stage/s only 0 – 4
- quality of sketches up to 2 [16]

[Total: 20]

Page 7	Mark Scheme	Syllabus	Paper
	Cambridge International A Level – October/November 2014	9705	32

- 9 (a) full front elevation 4
correct sectional elevation 5
correct projection 1
fully dimensioned 2
quality of line 2 [14]

- (b) explanation could include:
– speed
– accuracy
– ease of storage
– communicating ideas

Quality of explanation
– logical, structured
– limited detail

4 – 6
0 – 3 [6]

[Total: 20]

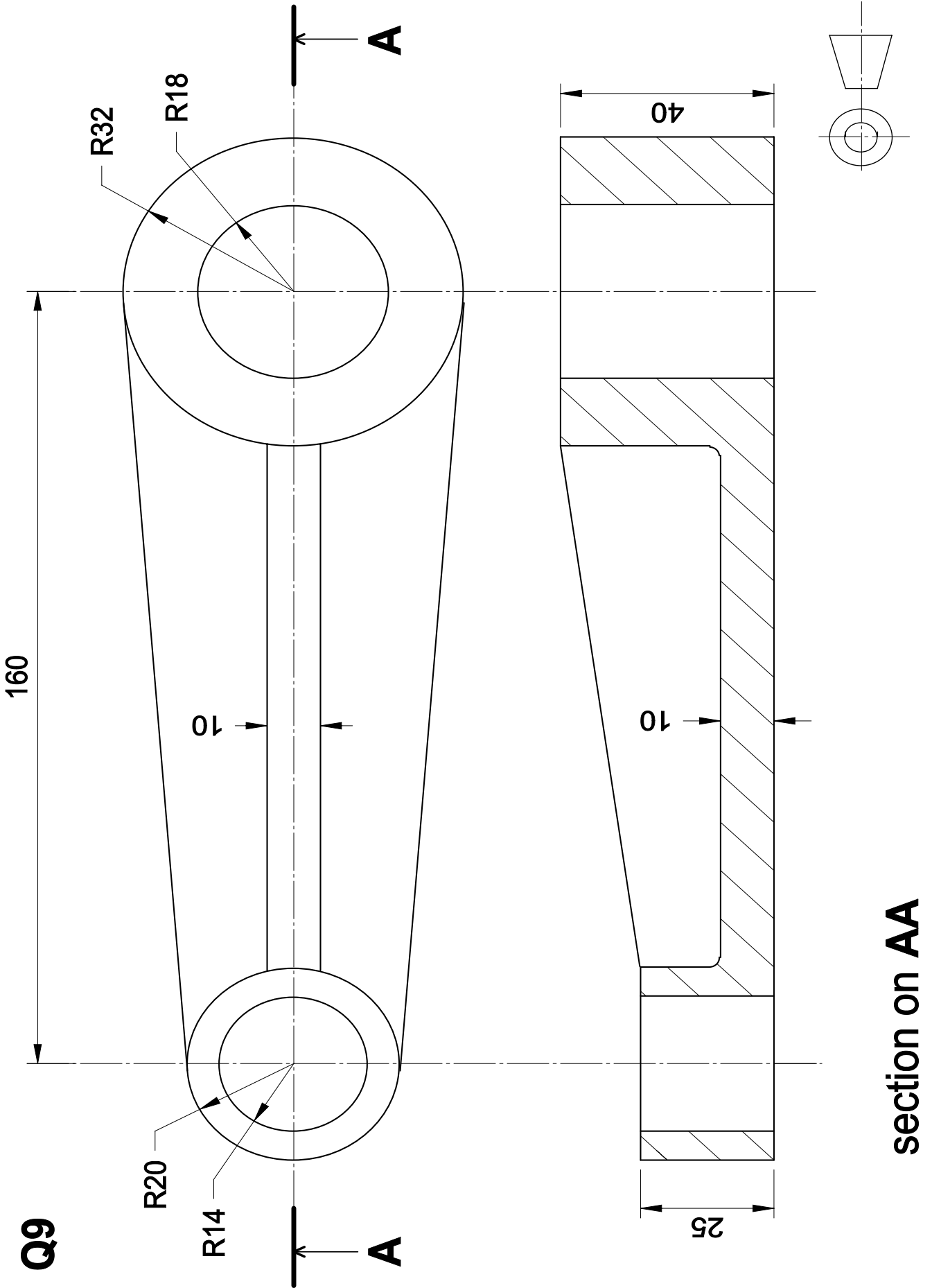

Page 9	Mark Scheme	Syllabus	Paper
	Cambridge International A Level – October/November 2014	9705	32

Section B

Analysis

Analysis of the given situation/problem. [5]

Specification

Detailed written specification of the design requirements.
At least five specification points other than those given in the question. [5]

Exploration

Bold sketches and brief notes to show exploration of ideas for a design solution, with reasons for selection.

- range of ideas [5]
- annotation related to specification [5]
- marketability, innovation [5]
- evaluation of ideas, selection leading to development [5]
- communication [5]

Development

Bold sketches and notes showing the development, reasoning and composition of ideas into a single design proposal. Details of materials, constructional and other relevant technical details.

- developments [5]
- reasoning [5]
- materials [3]
- constructional detail [7]
- communication [5]

Proposed solution

Produce drawing/s of an appropriate kind to show the complete solution.

- proposed solution [10]
- details/dimensions [5]

Evaluation

Written evaluation of the final design solution. [5]

[Total: 80]