DESIGN AND TECHNOLOGY

9705/31

Paper 3

October/November 2017

3 hours

Additional Materials: Answer Booklet/Paper
 A range of design drawing equipment
 A3 Drawing Paper (5 sheets)



READ THESE INSTRUCTIONS FIRST

Write your Centre number, candidate number and name on all the work you hand in.
Write in dark blue or black pen.
You may use an HB pencil for any diagrams, graphs or rough working.
Do not use staples, paper clips, glue or correction fluid.
DO NOT WRITE IN ANY BARCODES.

Section A

Answer any **two** questions from **one** of the Parts **A**, **B** or **C**.

Section B

Answer **one** question.

All dimensions are in millimetres.

The instruction 'discuss' denotes that you should:

- examine critically the issues raised by the question;
- explain and interpret these issues as appropriate;
- introduce evidence wherever possible to support conclusions of arguments.

At the end of the examination, fasten all your work securely together.

The number of marks is given in brackets [] at the end of each question or part question.

This document consists of **10** printed pages and **2** blank pages.

Section A

Answer any **two** questions from **one** of the Parts **A**, **B** or **C**.

Part A – Product Design

- 1 Designers often use models when designing products.

Use examples for each of the following to explain the importance of modelling in the design process.

- 2D modelling
- 3D modelling
- mock-ups
- scale prototype

[20]

- 2 Fig. 1 shows a shape sorter toy for a child and one triangular shape.

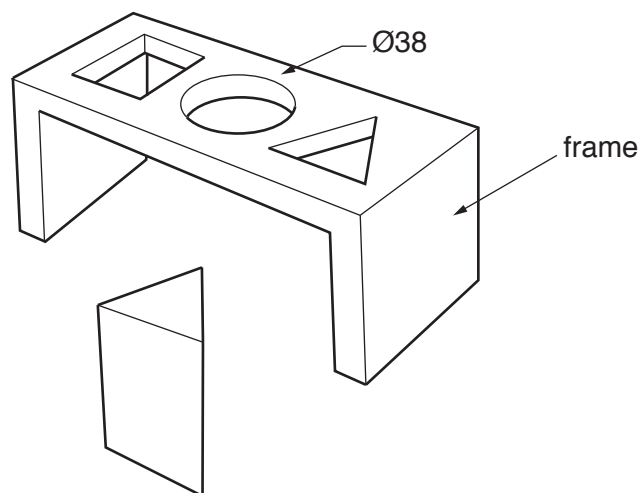
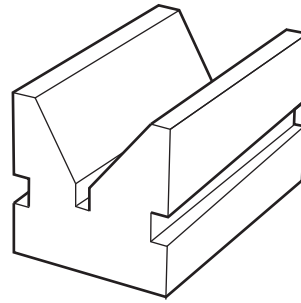

Fig. 1

- (a) State a suitable material for a shape sorter frame of the type shown in Fig. 1. Give **two** reasons for your choice. [3]
- (b) Describe, using notes and sketches, how you would make the shape sorter frame. [10]
- (c) Describe, using notes and sketches, how you would manufacture 5000 triangular shapes. [7]

item: mild steel vee block
process: milling



item: birch chair seat and back
process: laminating

item: melamine formaldehyde school dinner plate
process: compression moulding

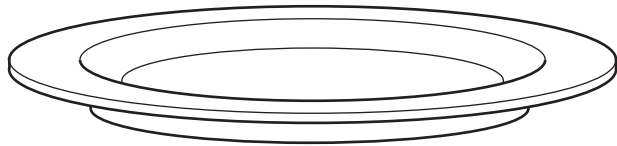

Fig. 2

Choose **two** of the items shown in Fig. 2. For **each**:

- (a) use notes and sketches to describe how the process has been used in the manufacture of the item; [14]
- (b) explain why the process is particularly suitable in the production of the item. [6]

Part B – Practical Technology

- 4 (a) (i) Calculate the power in a circuit if the voltage is 12V and the current is 2.4A. [3]
- (ii) Describe, using examples, **two** different ways of providing electrical power to a product. [4]
- (b) Fig. 3 shows an idea for a circuit for a security alarm to indicate that a door had been opened.

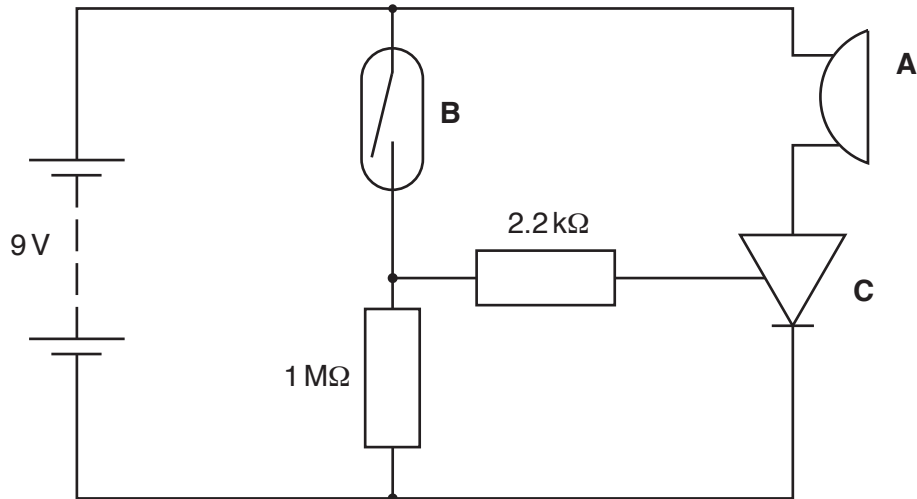

Fig. 3

- (i) Name components **A**, **B** and **C**. [3]
- (ii) Explain how the circuit works. [10]
- 5 Discuss the following quote attributed to Pablo Picasso with reference to the impact of computers in the designing of products.

'Computers are useless. They can only give us answers.'

[20]

6 Fig. 4 shows forces acting on a point.

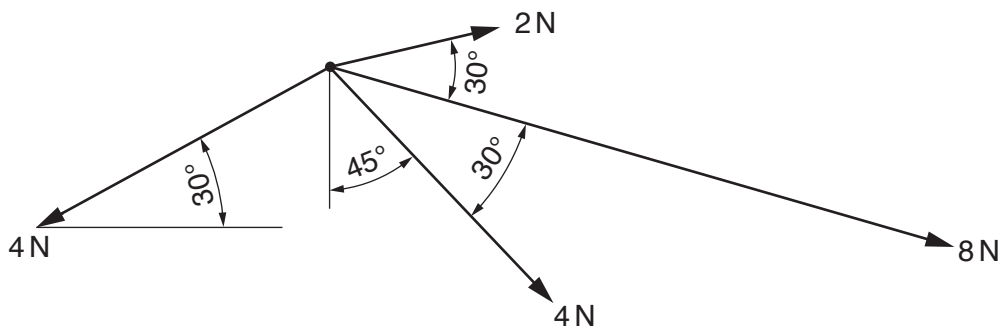

Fig. 4

(a) Determine the direction and magnitude of the resultant force.

[4]

(b) Fig. 5 shows a roof truss.

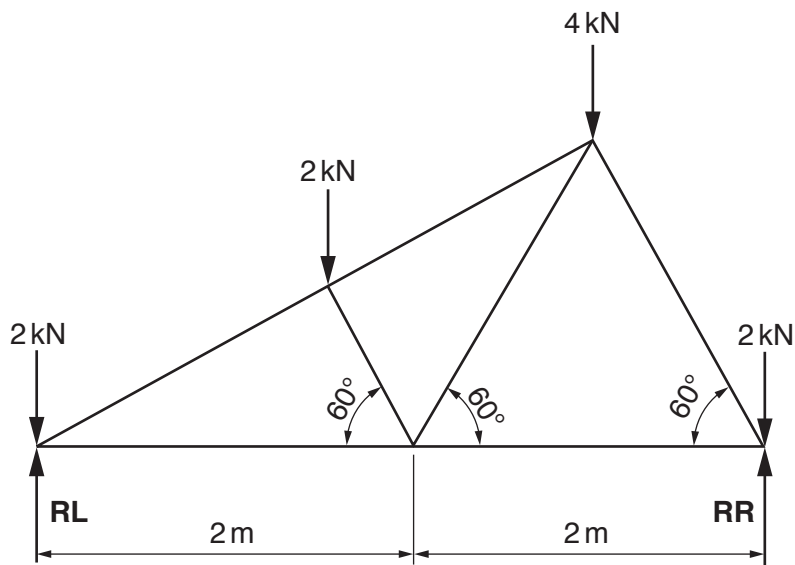

Fig. 5

(i) Determine the reactions at **RL** and **RR**.

[2]

(ii) Determine the magnitude of the forces in all of the members and identify whether they are ties or struts.

[14]

Part C – Graphic Products

7 (a) Construct a cam profile and displacement diagram from the following information.

- (i) cam shaft diameter 24
- (ii) in line flat follower
- (iii) minimum distance of 24 from the flat follower to camshaft centre
- (iv) clockwise direction
- (v) $0^\circ - 180^\circ$ rise 30 with simple harmonic motion
- (vi) $180^\circ - 210^\circ$ dwell
- (vii) $210^\circ - 360^\circ$ fall 30 with simple harmonic motion

[15]

(b) Give an example of an application of a ratchet mechanism. Use a labelled sketch to describe how a ratchet mechanism works. [5]

8 (a) Fig. 6 shows a crank mechanism.

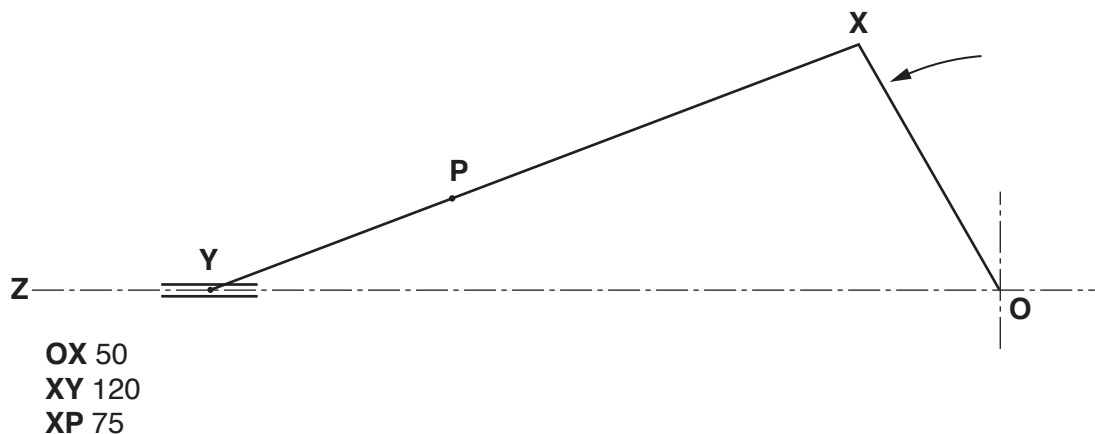

Fig. 6

Crank **OX** rotates, and is connected to arm **XY**.

Y is constrained to slide along line **OZ**.

- (i) Plot the loci of point **P** for one revolution of **OX**. [8]
- (ii) Draw the profile of a guard to enclose the whole mechanism with clearance of 10 mm. [4]

(b) Fig. 7 shows orthographic views of a toy truck made from seven parts.

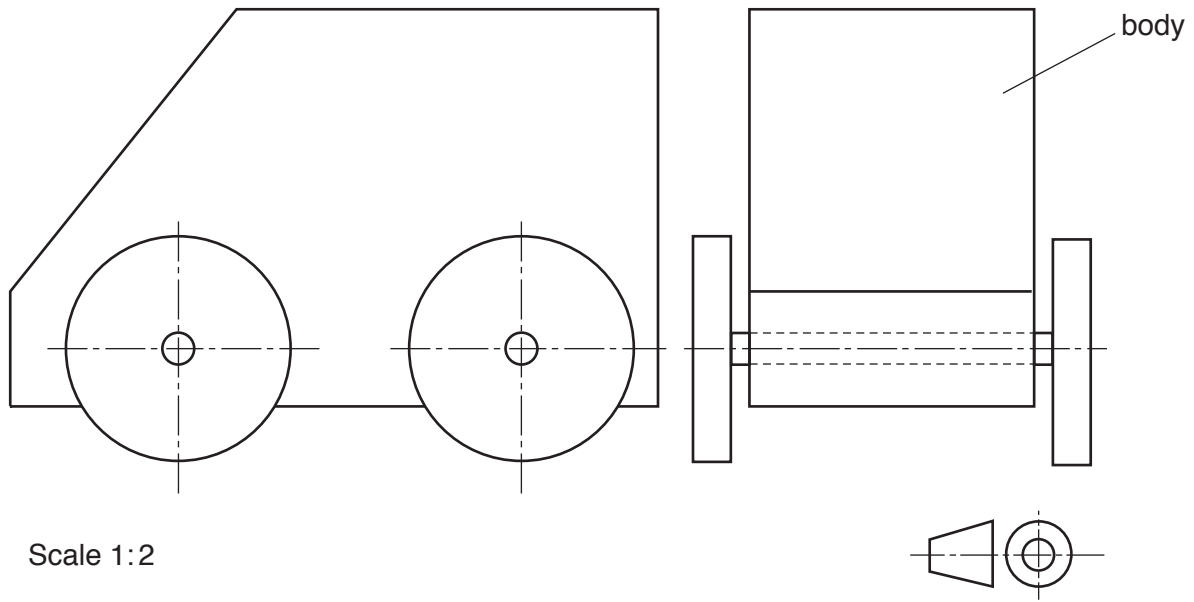

Fig. 7

Sketch an exploded isometric view of the toy truck. Render the body of the truck to look as though it is made from wood. [8]

9 Discuss the impact of advances in technology in the graphics industry with reference to:

- the graphic designer or illustrator;
- the manufacturer of graphic products;
- the consumer/user.

[20]

Section B

Answer **one** question on the A3 paper provided.

You should approach the design question of your choice in the following manner:

Analysis

Produce an analysis of the given situation/problem, which may be in written or graphical form. [5]

Specification

From the analysis produce a detailed written specification of the design requirements. Include at least five specification points other than those given in the question. [5]

Exploration

Use bold sketches and brief notes to show your exploration of ideas for a design solution, with reasons for selection. [25]

Development

Use bold sketches and notes to show the development, reasoning and composition of ideas into a single design proposal. Give details of materials, constructional and other relevant technical details. [25]

Proposed solution

Produce drawings of an appropriate kind to show the complete solution. [15]

Evaluation

Give a written evaluation of the final design solution. [5]

Total: [80]

- 10** When very large numbers of people are evacuated because of natural disasters, there is an urgent need for temporary shelters.

Design a temporary shelter.

The shelter must:

- be easily transportable;
- be easily assembled;
- accommodate up to 3 adults.

Anthropometric data is given in Fig. 8.

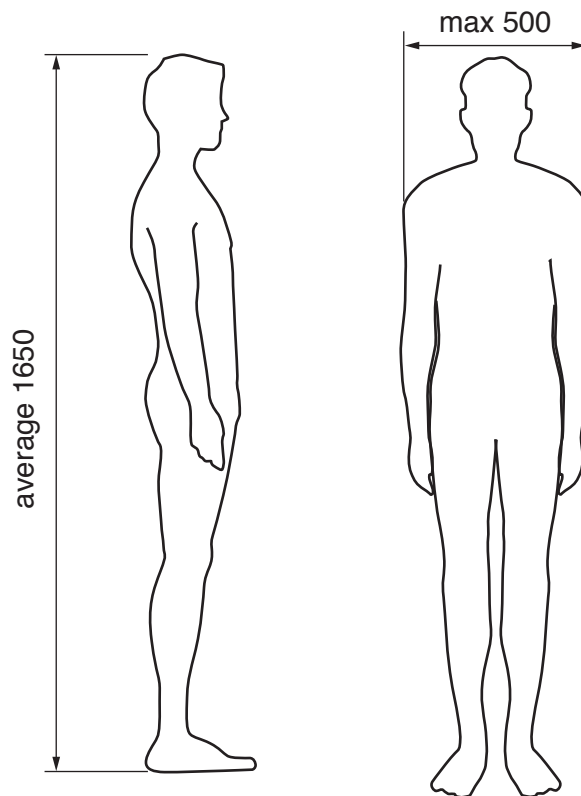

Fig. 8

- 11** A new school wishes to ensure that students and visitors are inspired and excited as they enter the school.

Design a kinetic sculpture to be erected in front of the school.

The sculpture must:

- be powered by wind;
- be visually interesting and create interesting sounds;
- be no more than 2.5 metres high.

- 12** Exercise is very important for the health and well-being of young people and adults. A large multi-national company wishes to promote a new range of fitness tracker bands under the brand name *uFit*. The bands are worn on the wrist and monitor energy related data. Items are required for a promotional campaign.

Design the packaging and a point of sale display.

- The packaging must hold the band and connecting cable.
- The point of sale display must hold at least **three** fitness bands.
- Both the packaging and point of sale display must include the brand name *uFit*.

Details of the band and connecting cable are given in Fig. 9.

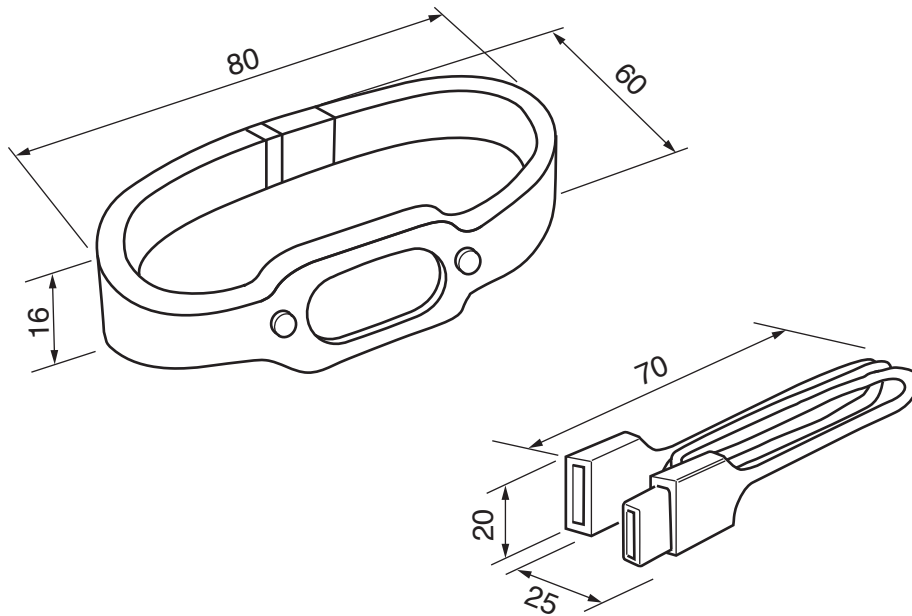

Fig. 9

BLANK PAGE

Permission to reproduce items where third-party owned material protected by copyright is included has been sought and cleared where possible. Every reasonable effort has been made by the publisher (UCLES) to trace copyright holders, but if any items requiring clearance have unwittingly been included, the publisher will be pleased to make amends at the earliest possible opportunity.

To avoid the issue of disclosure of answer-related information to candidates, all copyright acknowledgements are reproduced online in the Cambridge International Examinations Copyright Acknowledgements Booklet. This is produced for each series of examinations and is freely available to download at www.cie.org.uk after the live examination series.

Cambridge International Examinations is part of the Cambridge Assessment Group. Cambridge Assessment is the brand name of University of Cambridge Local Examinations Syndicate (UCLES), which is itself a department of the University of Cambridge.