

**DESIGN AND TECHNOLOGY**

**9705/12**

Paper 1

**October/November 2017**

**3 hours**

Additional Materials:      Answer Booklet/A4 Paper  
   A3 Drawing Paper (2 sheets)  
   Extra sheets of A3 drawing paper for candidates who have used up both sides of  
   their 2 sheets  
   A range of design drawing equipment



**READ THESE INSTRUCTIONS FIRST**

If you have been given an Answer Booklet, follow the instructions on the front cover of the Booklet.  
Write your answers and working on the separate Answer Booklet/Paper provided.  
Write your name, Centre number and candidate number on all the work you hand in.  
Write in dark blue or black pen.  
You may use an HB pencil, or coloured pencils/pens as appropriate, for any diagrams, graphs or rough working.  
Do not use staples, paper clips, glue or correction fluid.  
**DO NOT WRITE IN ANY BARCODES.**

**Section A**  
Answer **one** question on the Answer Booklet/A4 Paper provided.

**Section B**  
Answer **one** question on the Answer Booklet/A4 Paper provided.

**Section C**  
Answer **one** question on plain A3 paper.  
Use **both** sides of the paper.  
You may request additional sheets of A3 paper, but only if you have used up both sides of each of the 2 sheets provided.

You are advised to spend **30 minutes** on each of Sections A and B and **2 hours** on Section C.

At the end of the examination, fasten all your work securely together.  
The number of marks is given in brackets [ ] at the end of each question or part question.  
All dimensions are in millimetres.

This document consists of **13** printed pages and **3** blank pages.

## Section A

Answer **one** question from this section on the Answer Booklet/A4 paper provided.

- 1 Fig. 1 gives details about a table lamp which is to be made in a school workshop. The base will be made from cast aluminium.

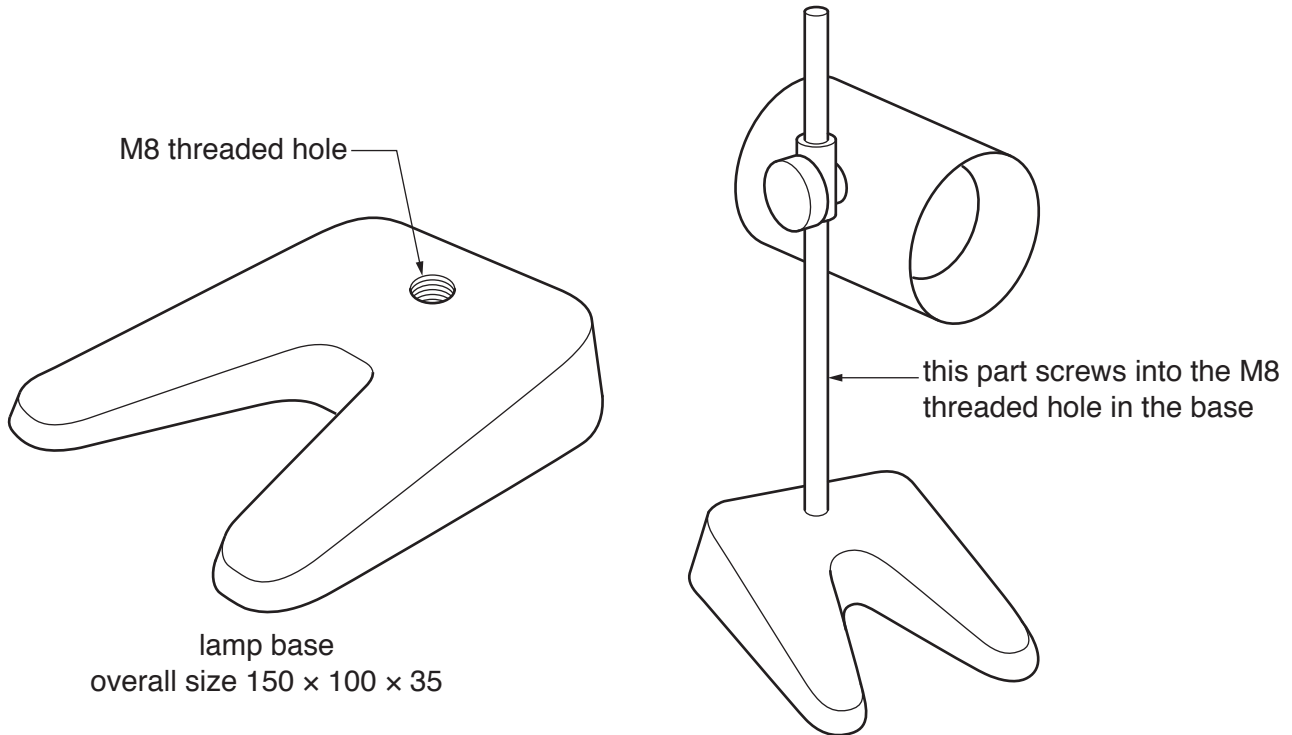

**Fig. 1**

- (a) Give **two** reasons why aluminium would be a suitable metal for casting the base. [2]
- (b) Use notes and sketches to describe:
- (i) how the pattern required to cast the base could be made; [6]
  - (ii) how the base could be cast; [6]
  - (iii) how the M8 threaded hole in the base could be made. [6]

You must give details about the tools, equipment and processes involved and the safety precautions that have to be undertaken at each stage.

**Question 2 begins on the next page.**

2 Fig. 2 gives details about a mechanical greeting card. A batch of twenty of these cards will be made in a school workshop. As the tab is pulled and pushed, the dog's ears move.

(a) Use a sketch and notes, to explain how many A5 cards could be printed on an A3 sheet. [2]

(b) Use notes and sketches to describe:

- (i) how the lettering and the drawing of the dog could be produced and printed onto A3 sheets of card; [6]
- (ii) how the slots in the greeting card could be made; [2]
- (iii) how the ears could be made and then attached to the greeting card; [4]
- (iv) how the linkage mechanism could be made and then attached to both the greeting card and the ears. [6]

You must give details about the tools, equipment and processes involved and the safety precautions that have to be undertaken at each stage.

lettering and drawing of dog  
produced and printed on card

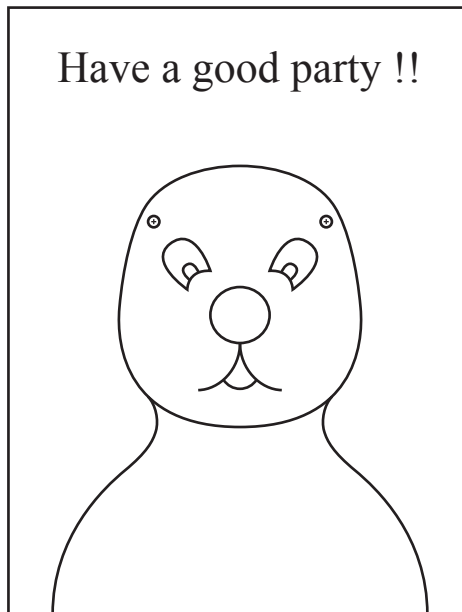

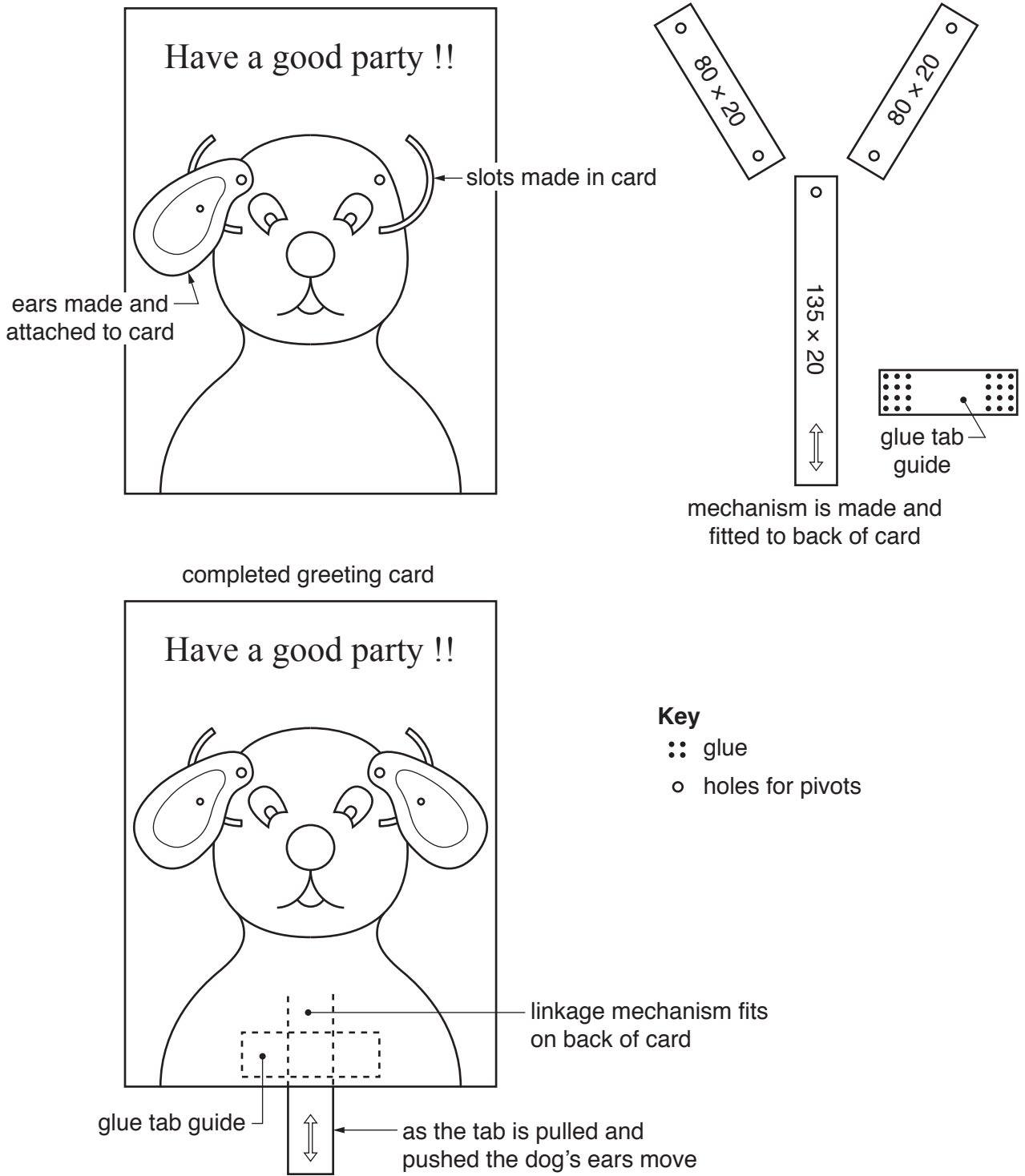

Fig. 2

- 3 Fig. 3 gives details about a child's constructional toy. The six wooden pieces fit together to make a model of a skyscraper.

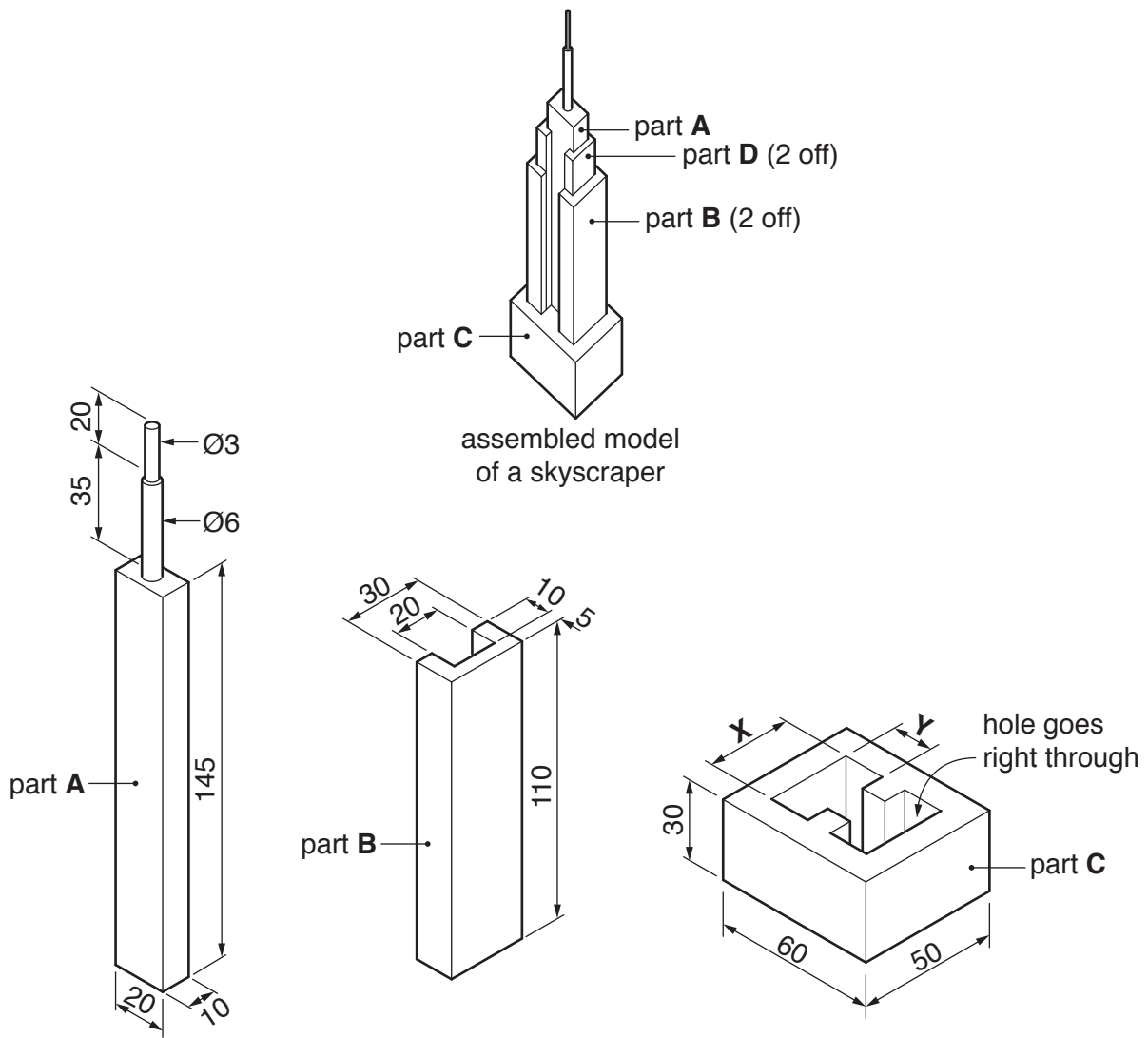

Fig. 3

- (a) State suitable dimensions for **X** and **Y** on part **C**. [2]
- (b) Use notes and sketches to describe how:
- (i) part **A** could be made; [6]
  - (ii) part **B** could be made; [6]
  - (iii) part **C** could be made. [6]

You must give details about the tools, equipment and processes involved and the safety precautions that have to be undertaken at each stage.

## Section B

Answer **one** question from this section on the Answer Booklet/A4 paper provided.

- 4 Fig. 4 shows part of a disc sander. The disc sander will be fixed to the floor in a school workshop.

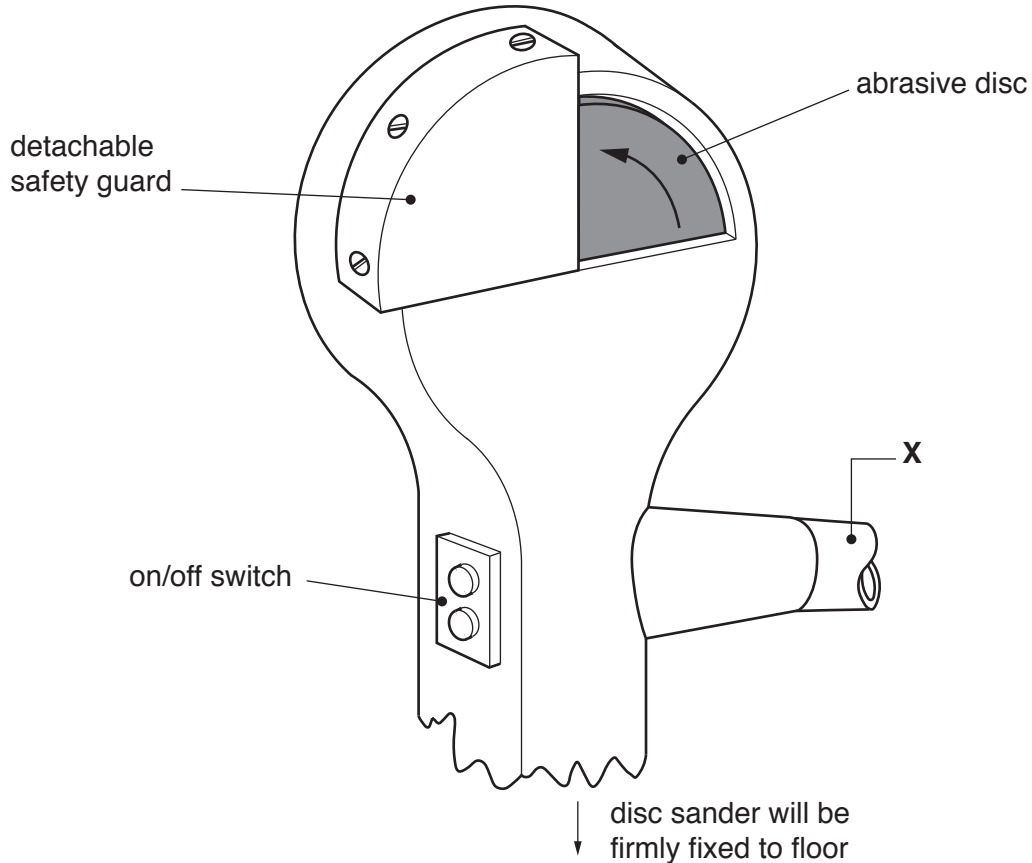

Fig. 4

- (a) Explain the function of the pipe shown at X. [2]
- (b) Identify and describe **two** problems with the design of the disc sander that make it unsafe to use. [4]
- (c) Using notes and sketches, explain how the design would need to be changed to overcome the **two** problems you have identified in part (b). [6]
- (d) Discuss the safety features on a variety of machines used by students in a school workshop and how these features help to avoid accidents.

Your answer should:

- (i) analyse the given situation and identify **three** relevant issues raised by the question; [3]
- (ii) explain why you consider these issues to be relevant; [3]
- (iii) contain specific examples/evidence to support your conclusions. [2]

- 5 Fig. 5 gives details about a perfume bottle and its packaging. The packaging consists of two parts, an insert and a sleeve into which the insert slides.

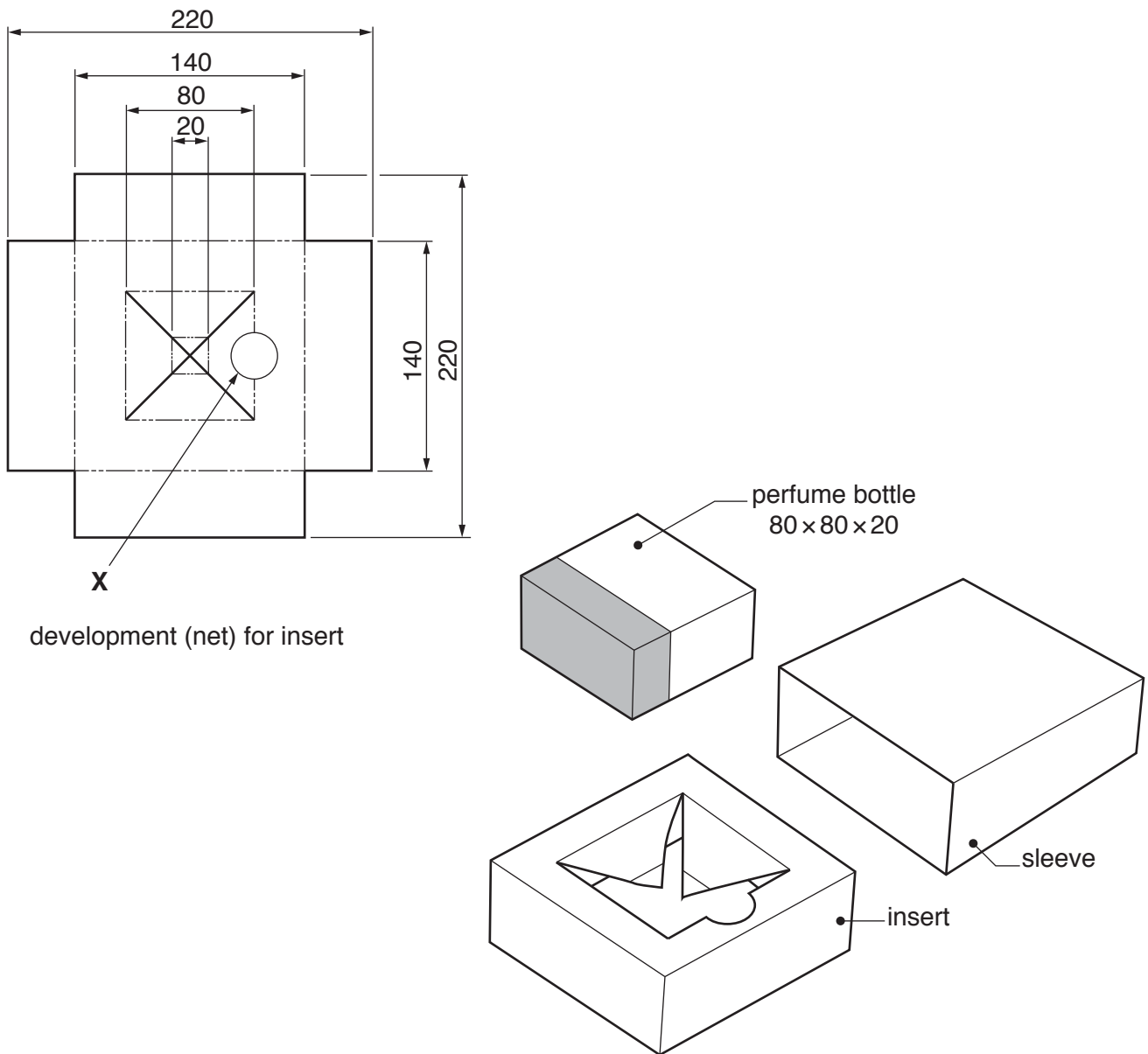

Fig. 5



- (a) Explain the function of the design feature shown at **X**. [2]
- (b) Identify and describe **two** problems with the development (net) required to make the insert. [4]
- (c) Using notes and sketches, explain how the development (net) would need to be changed to overcome the **two** problems you have identified in **part (b)**. [6]
- (d) Discuss how the colours and surface finishes used on packaging can influence the sales of a product.

Your answer should:

- (i) analyse the given situation and identify **three** relevant issues raised by the question; [3]
- (ii) explain why you consider these issues to be relevant; [3]
- (iii) contain specific examples/evidence to support your conclusions. [2]

- 6 Fig. 6 shows a design for a table and seats which will be located in a park or other public space. Details are also given about wheelchair sizes.

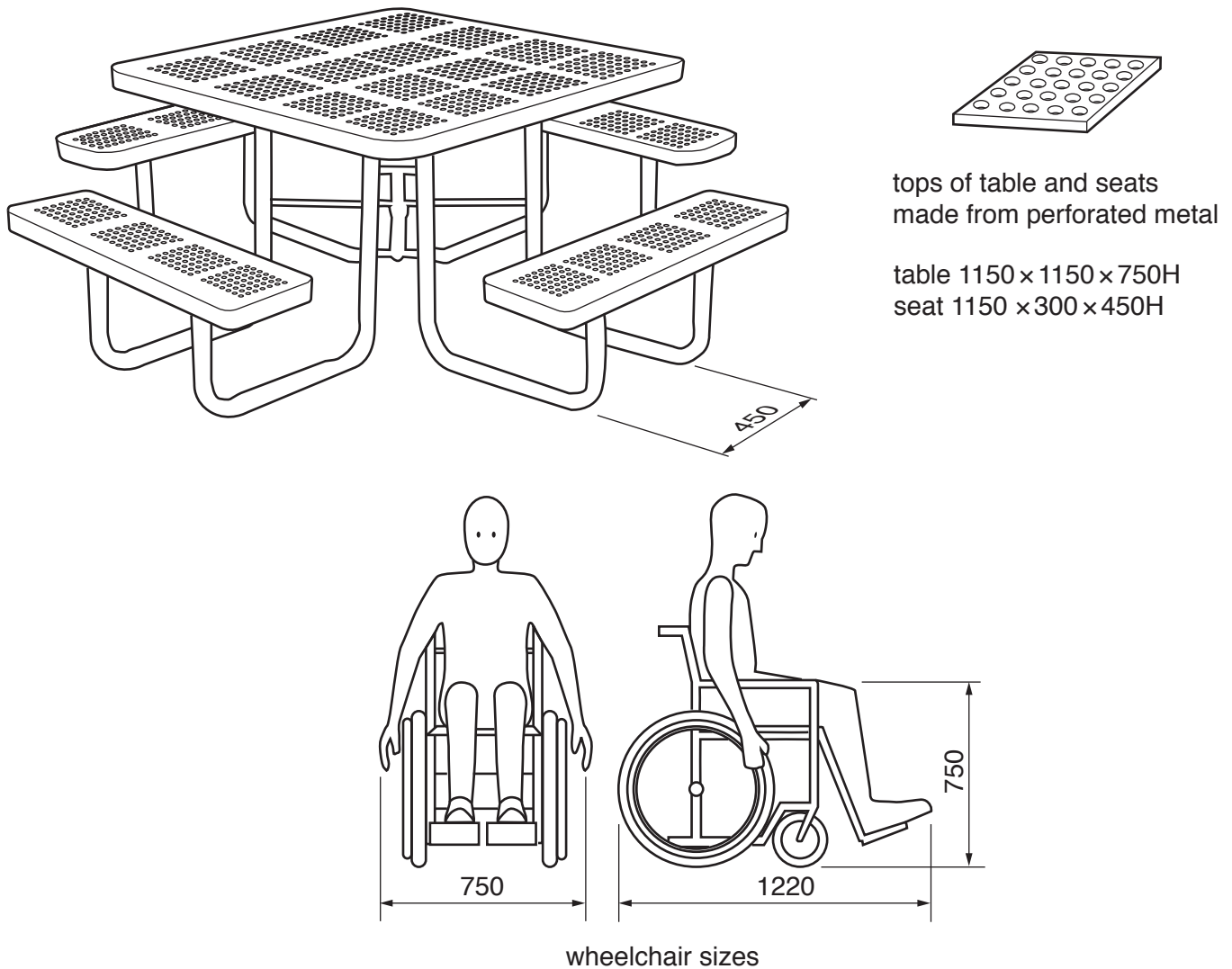

Fig. 6

- (a) Explain why perforated metal is a material that is often used in the manufacture of outdoor furniture. [2]
- (b) Identify and describe **two** problems with the design that would make it difficult for a person in a wheelchair to use the table. [4]
- (c) Using notes and sketches, explain how the design would need to be changed to overcome the **two** problems you have identified in **part (b)**. [6]
- (d) Discuss how and why designers need to gather information about the needs of different user groups before they start to design a product.

Your answer should:

- (i) analyse the given situation and identify **three** relevant issues raised by the question; [3]
- (ii) explain why you consider these issues to be relevant; [3]
- (iii) contain specific examples/evidence to support your conclusions. [2]

## Section C

Answer **one** question from this section on the plain A3 paper provided.

You are provided with two sheets of plain A3 paper. You should use **both** sides of the paper. **Each** of the four parts **(a)–(d)** of the question you choose to answer should take up one side of paper.

When you are asked to **develop** a design you must show, using notes and sketches, the development and evaluation of a **range** of ideas into a single design proposal. The design proposal should be annotated to give details about materials, joining methods and important sizes.

7 Fig. 7 shows an incomplete design for a student's desk.

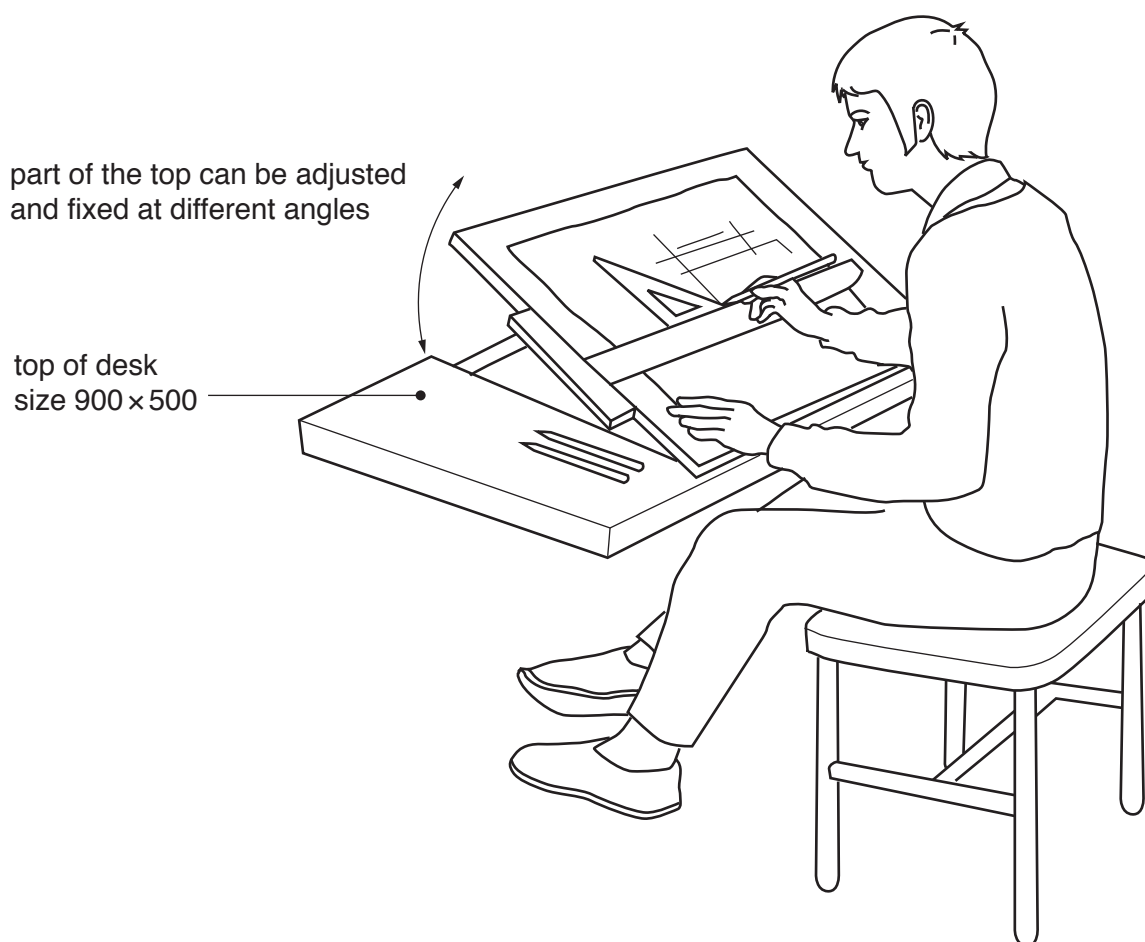

Fig. 7

- (a) Using notes and sketches, **develop** a design which supports the top of the desk at a height of 750 mm. [20]
- (b) Using notes and sketches, **develop** a design which allows part of the top of the desk to be adjusted and fixed at different angles. [20]
- (c) Using notes and sketches, **develop** a design for three drawers that will fit under the desk. Your design must include details about how the drawers will be attached to the main structure of the desk. [20]
- (d) Produce a pictorial rendered drawing of the complete desk which shows all of the features that you have designed in **parts (a)–(c)**. [20]

- 8 Fig. 8 shows an incomplete idea for a folder to hold A2 sheets of paper. The folder will be made from thin corrugated plastic sheet.

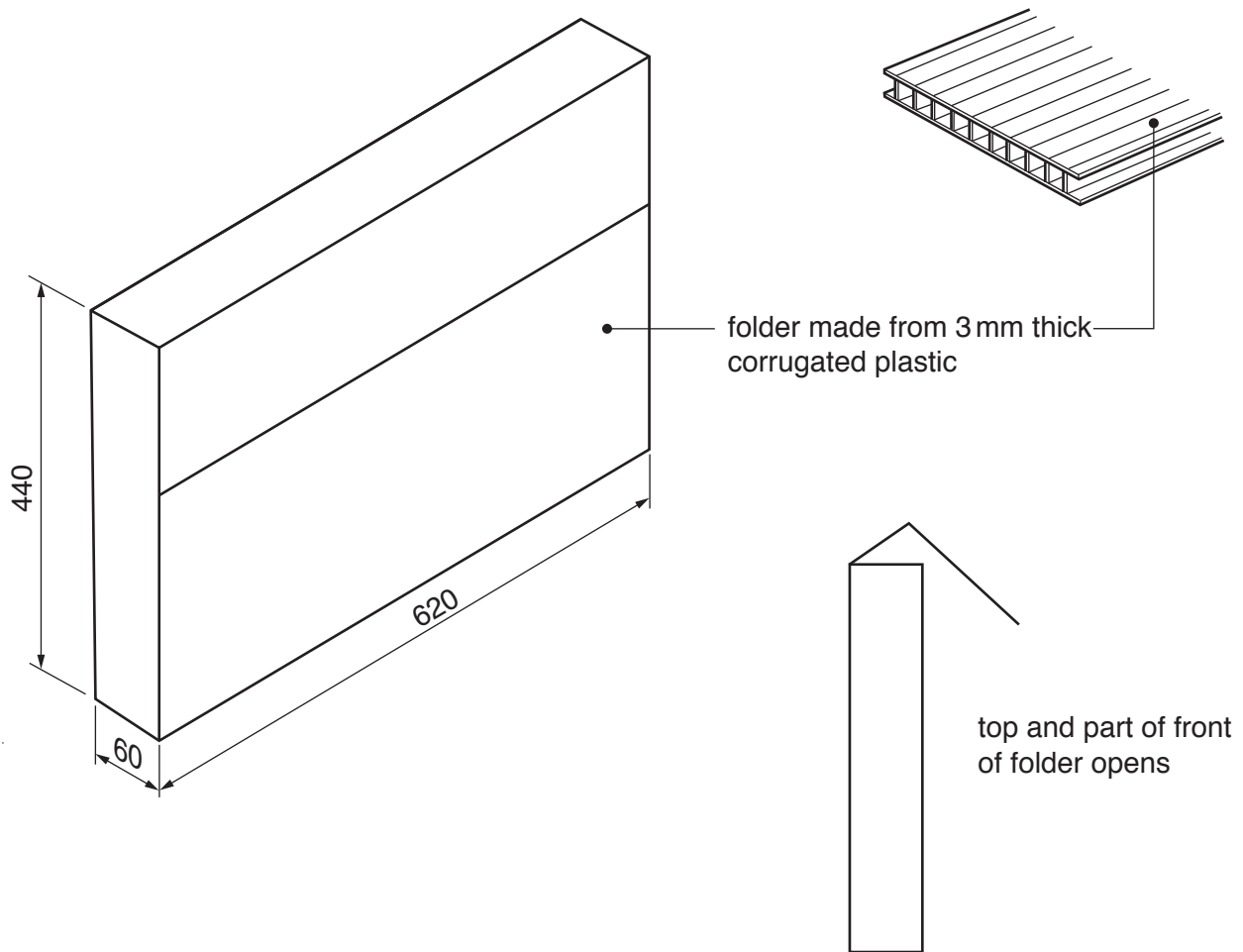

Fig. 8

- (a) Using notes and sketches, **develop** a design for the folder. The folder must be made from a one piece development (net) which is held together without the use of glue. Your design must include details of the one piece development (net) required to make the folder. [20]
- (b) Using notes and sketches, **develop** designs that:
- (i) allow the folder to be carried;
  - (ii) keep the folder securely closed. [20]
- (c) Using notes and sketches, **develop** a design for the lettering to go on the folder. This will be the words '**Graphic Design**' and the lettering should be in a style that reflects this name. [20]
- (d) Produce a pictorial rendered drawing of the complete folder which shows all of the features that you have designed in **parts (a)–(c)**. [20]

9 Fig. 9 shows an incomplete idea for a wind powered mechanical toy dog.

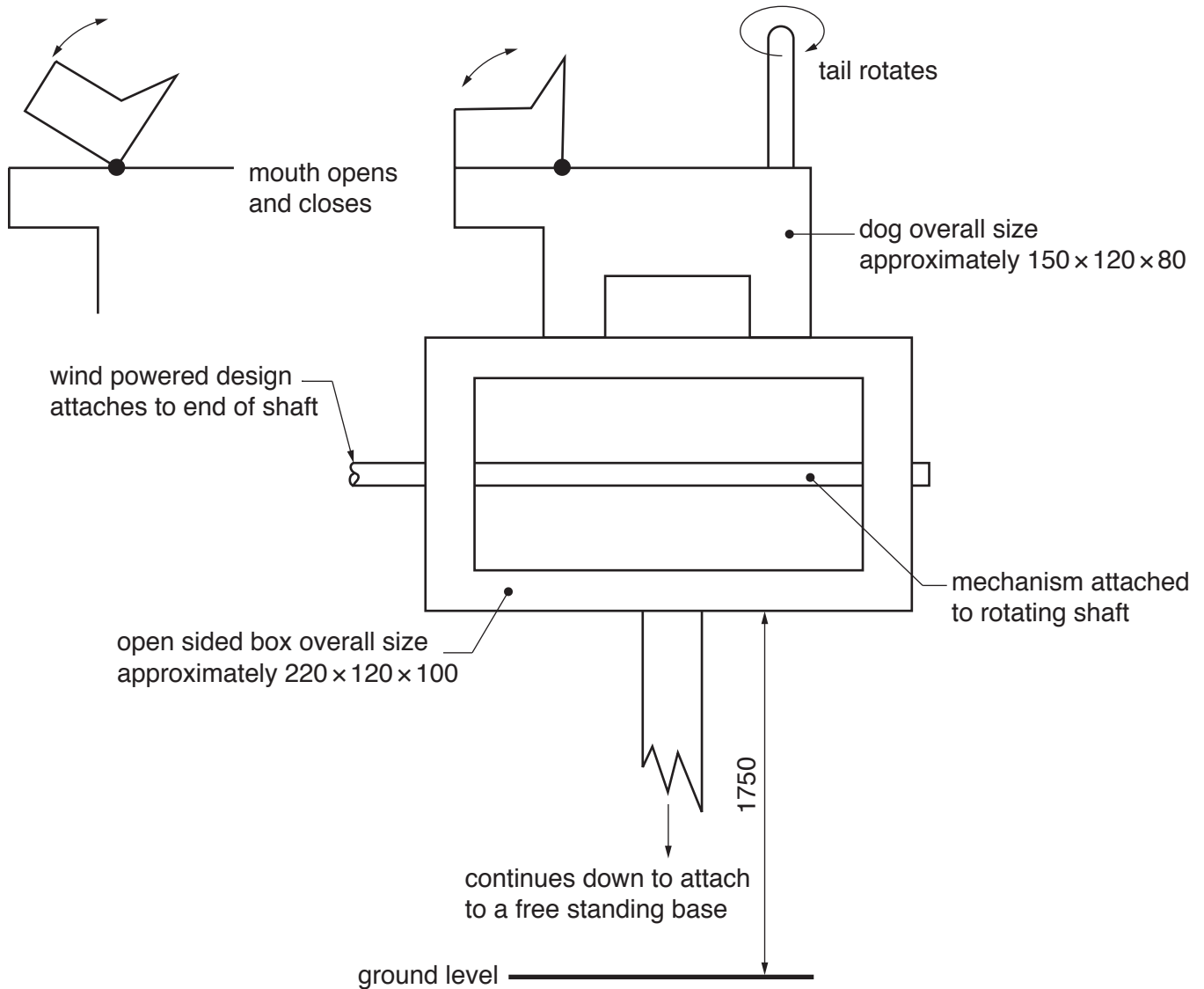

Fig. 9

- (a) Using notes and sketches, **develop** a design that will make the shaft rotate when the wind blows. [20]
- (b) Using notes and sketches, **develop** designs for the open sided box, the dog and the mechanism that will be attached to the shaft to make the parts of the dog move as shown in Fig. 9. [20]
- (c) Using notes and sketches, **develop** a design for a free standing base that will support the mechanical toy at a height of 1750 mm. [20]
- (d) Produce a pictorial rendered drawing of the complete wind powered mechanical toy that shows all of the features you have designed in **parts (a)–(c)**. [20]





**BLANK PAGE**

---

Permission to reproduce items where third-party owned material protected by copyright is included has been sought and cleared where possible. Every reasonable effort has been made by the publisher (UCLES) to trace copyright holders, but if any items requiring clearance have unwittingly been included, the publisher will be pleased to make amends at the earliest possible opportunity.

To avoid the issue of disclosure of answer-related information to candidates, all copyright acknowledgements are reproduced online in the Cambridge International Examinations Copyright Acknowledgements Booklet. This is produced for each series of examinations and is freely available to download at [www.cie.org.uk](http://www.cie.org.uk) after the live examination series.

Cambridge International Examinations is part of the Cambridge Assessment Group. Cambridge Assessment is the brand name of University of Cambridge Local Examinations Syndicate (UCLES), which is itself a department of the University of Cambridge.