

1

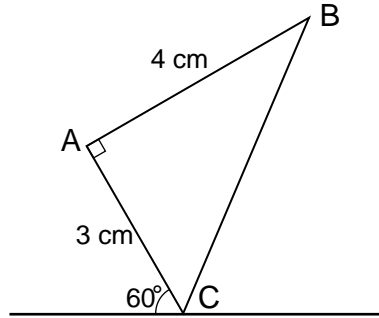

A uniform prism has a cross-section in the form of a triangle  $ABC$  which is right-angled at  $A$ . The sides  $AB$  and  $AC$  have lengths 4 cm and 3 cm respectively. The prism is held with the edge containing  $C$  in contact with a horizontal surface and with  $AC$  making an angle of  $60^\circ$  with the horizontal (see diagram). The prism is now released. Determine whether it will tip on the face containing  $AC$  or the face containing  $BC$ . [4]

2

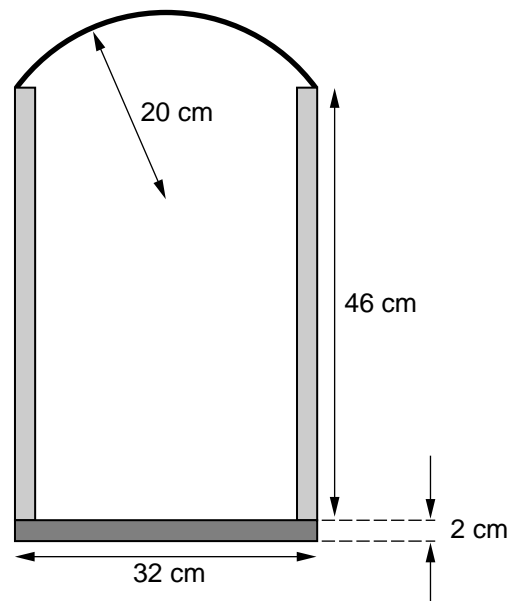

A bucket that consists of three parts stands on horizontal ground. The base is in the form of a uniform circular disc of diameter 32 cm and thickness 2 cm. The body is in the form of a uniform hollow cylinder of outer diameter 32 cm and height 46 cm. The handle is a vertical arc, attached at opposite ends of an outer diameter at the top of the cylinder. The handle is in the form of a uniform circular arc of radius 20 cm. The diagram shows the cross-section of the bucket in the plane of the handle.

- (i) Show that the centre of mass of the handle is 53.25 cm above the ground, correct to 4 significant figures. [3]

The weights of the base, body and handle are 50 N, 100 N and 25 N respectively.

- (ii) Find the height of the centre of mass of the bucket above the ground. [2]

3

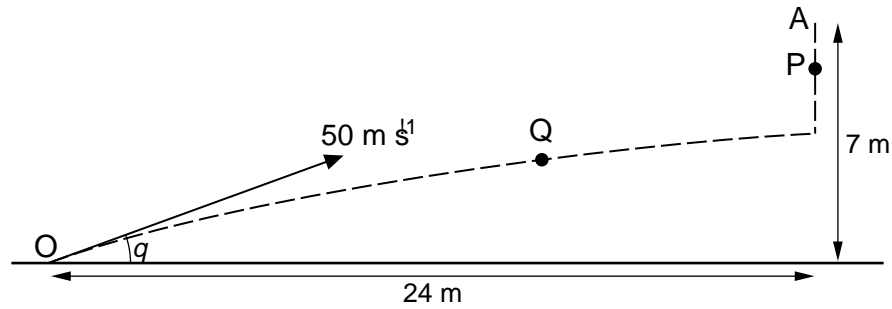

A particle P is released from rest at a point A which is 7 m above horizontal ground. At the same instant that P is released a particle Q is projected from a point O on the ground. The horizontal distance of O from A is 24 m. Particle Q moves in the vertical plane containing O and A, with initial speed  $50 \text{ m s}^{-1}$  and initial direction making an angle  $\alpha$  above the horizontal, where  $\tan \alpha = \frac{7}{24}$  (see diagram). Show that the particles collide. [6]

- 4 One end of a light elastic string of natural length 3 m and modulus of elasticity 15 N is attached to a fixed point O. A particle P of mass  $m \text{ kg}$  is attached to the other end of the string. P is released from rest at O and moves vertically downwards. When the extension of the string is  $x \text{ m}$  the velocity of P is  $v \text{ m s}^{-1}$ .

(i) Show that  $v^2 = 5(12 - 4x) - x^2$ . [4]

- (ii) Find the magnitude of the acceleration of P when it is at its lowest point, and state the direction of this acceleration. [3]

5

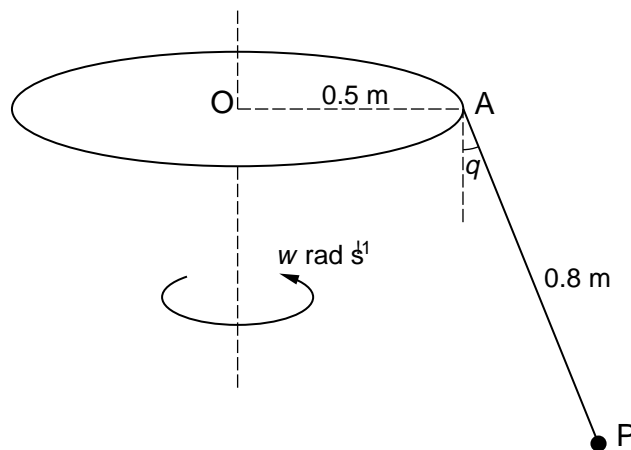

A horizontal disc of radius 0.5 m is rotating with constant angular speed  $\omega \text{ rad s}^{-1}$  about a fixed vertical axis through its centre O. One end of a light inextensible string of length 0.8 m is attached to a point A of the circumference of the disc. A particle P of mass 0.4 kg is attached to the other end of the string. The string is taut and the system rotates so that the string always lies in the same vertical plane as the radius OA of the disc. The string makes a constant angle  $\alpha$  with the vertical (see diagram). The speed of P is 1.6 times the speed of A.

(i) Show that  $\sin \alpha = \frac{3}{8}$ . [3]

- (ii) Find the tension in the string. [2]

- (iii) Find the value of  $\omega$ . [3]

6

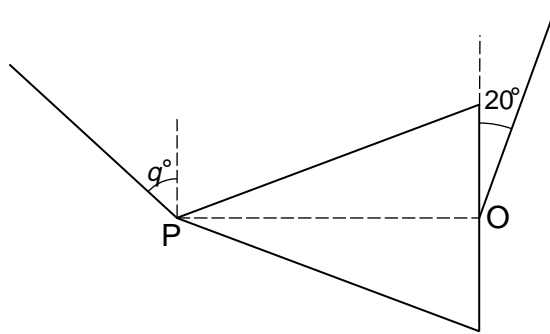

P is the vertex of a uniform solid cone of mass 5 kg, and O is the centre of its base. Strings are attached to the cone at P and at O. The cone hangs in equilibrium with PO horizontal and the strings taut. The strings attached at P and O make angles of  $\alpha^\circ$  and  $20^\circ$ , respectively, with the vertical (see diagram, which shows a cross-section).

- (i) By taking moments about P for the cone, find the tension in the string attached at O [4]
- (ii) Find the value of  $\alpha$  and the tension in the string attached at P [6]

7 A particle P of mass 0.3 kg is projected vertically upwards from the ground with an initial speed of  $20 \text{ m s}^{-1}$ . When P is at height  $x \text{ m}$  above the ground, its upward speed is  $v \text{ s}^{-1}$ . It is given that

$$3v \cdot 90 \ln \frac{v}{20} = 30Ax, \quad A,$$

where A is a constant.

- (i) Differentiate this equation with respect to  $x$  and hence show that the acceleration of the particle is  $\frac{1}{3}A \text{ m s}^{-2}$ . [3]
- (ii) Find, in terms of  $v$ , the resisting force acting on the particle. [2]
- (iii) Find the time taken for P to reach its maximum height. [5]

Permission to reproduce items where third-party owned material protected by copyright is included has been sought and cleared where possible. Every reasonable effort has been made by the publisher (UCLES) to trace copyright holders, but if any items requiring clearance have unwittingly been included, the publisher will be pleased to make amends at the earliest possible opportunity.

University of Cambridge International Examinations is part of the Cambridge Assessment Group. Cambridge Assessment is the brand name of University of Cambridge Local Examinations Syndicate (UCLES), which is itself a department of the University of Cambridge.



UNIVERSITY OF CAMBRIDGE INTERNATIONAL EXAMINATIONS  
General Certificate of Education Advanced Level

**MATHEMATICS**

**9709/52**

Paper 5 Mechanics 2 (M2)

**October/November 2009**

**1 hour 15 minutes**

Additional Materials:      Answer Booklet/Paper  
   Graph Paper  
   List of Formulae (MF9)



**READ THESE INSTRUCTIONS FIRST**

If you have been given an Answer Booklet, follow the instructions on the front cover of the Booklet.

Write your Centre number, candidate number and name on all the work you hand in.

Write in dark blue or black pen.

You may use a soft pencil for any diagrams or graphs.

Do not use staples, paper clips, highlighters, glue or correction fluid.

Answer **all** the questions.

Give non-exact numerical answers correct to 3 significant figures, or 1 decimal place in the case of angles in degrees, unless a different level of accuracy is specified in the question.

Where a numerical value for the acceleration due to gravity is needed, use  $10 \text{ m s}^{-2}$ .

The use of an electronic calculator is expected, where appropriate.

You are reminded of the need for clear presentation in your answers.

At the end of the examination, fasten all your work securely together.

The number of marks is given in brackets [ ] at the end of each question or part question.

The total number of marks for this paper is 50.

Questions carrying smaller numbers of marks are printed earlier in the paper, and questions carrying larger numbers of marks later in the paper.

This document consists of **4** printed pages.

