

Centre Number	Candidate Number	Name
---------------	------------------	------

CAMBRIDGE INTERNATIONAL EXAMINATIONS
International General Certificate of Secondary Education

DESIGN AND TECHNOLOGY

0445/04

Paper 4 Technology

May/June 2003

1 hour

Candidates answer on the Question Paper.
No additional materials are required.

To be taken together with Paper 1 in one session of 2 hours 45 minutes.

READ THESE INSTRUCTIONS FIRST

Write your Centre number, candidate number and name on all the work you hand in.
Write in dark blue or black pen in the spaces provided on the Question Paper.
You may use a soft pencil for any diagrams, graphs or rough working.
Do not use staples, paper clips, highlighters, glue or correction fluid.

Answer any **two** questions.
The number of marks is given in brackets [] at the end of each question or part question.
You may use a calculator.

If you have been given a label, look at the details. If any details are incorrect or missing, please fill in your correct details in the space given at the top of this page.

Stick your personal label here, if provided.

For Examiner's Use	
1	
2	
3	
4	
TOTAL	

This document consists of **18** printed pages and **2** blank pages.

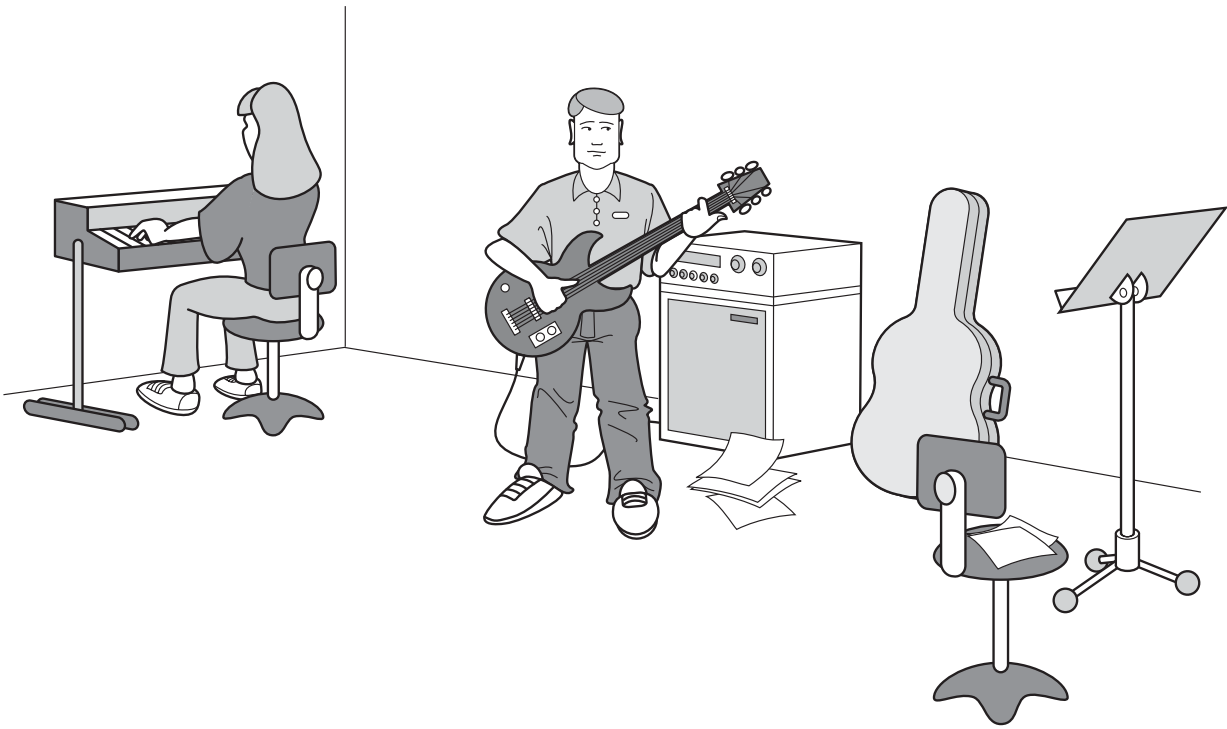

Fig. 1

1 A student is designing an electronic sound effects device for using with an electric guitar (Fig. 1).

(a) The circuit is to be modelled using a "breadboard" as shown in Fig. 2.

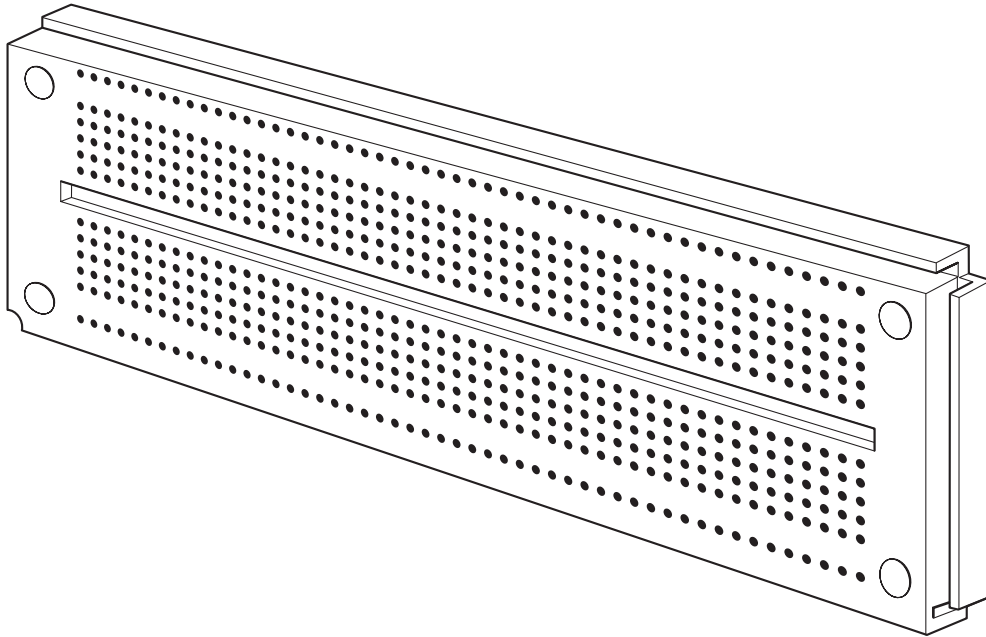

Fig. 2

(i) Give **one** reason for modelling the circuit before creating a printed circuit board.

.....
.....
.....
..... [2]

(ii) Add labels to Fig. 2 to show the positive and negative rails. [2]

(iii) State **one** other method of modelling circuits before manufacturing them.

..... [1]

(b) The final circuit will be made using a printed circuit board and discrete components.

(i) Give **one** benefit of using printed circuit boards when making electronic products.

.....
.....
..... [2]

- (ii) Complete the flow diagram in Fig.3 below to show the main steps in the production of a printed circuit board.

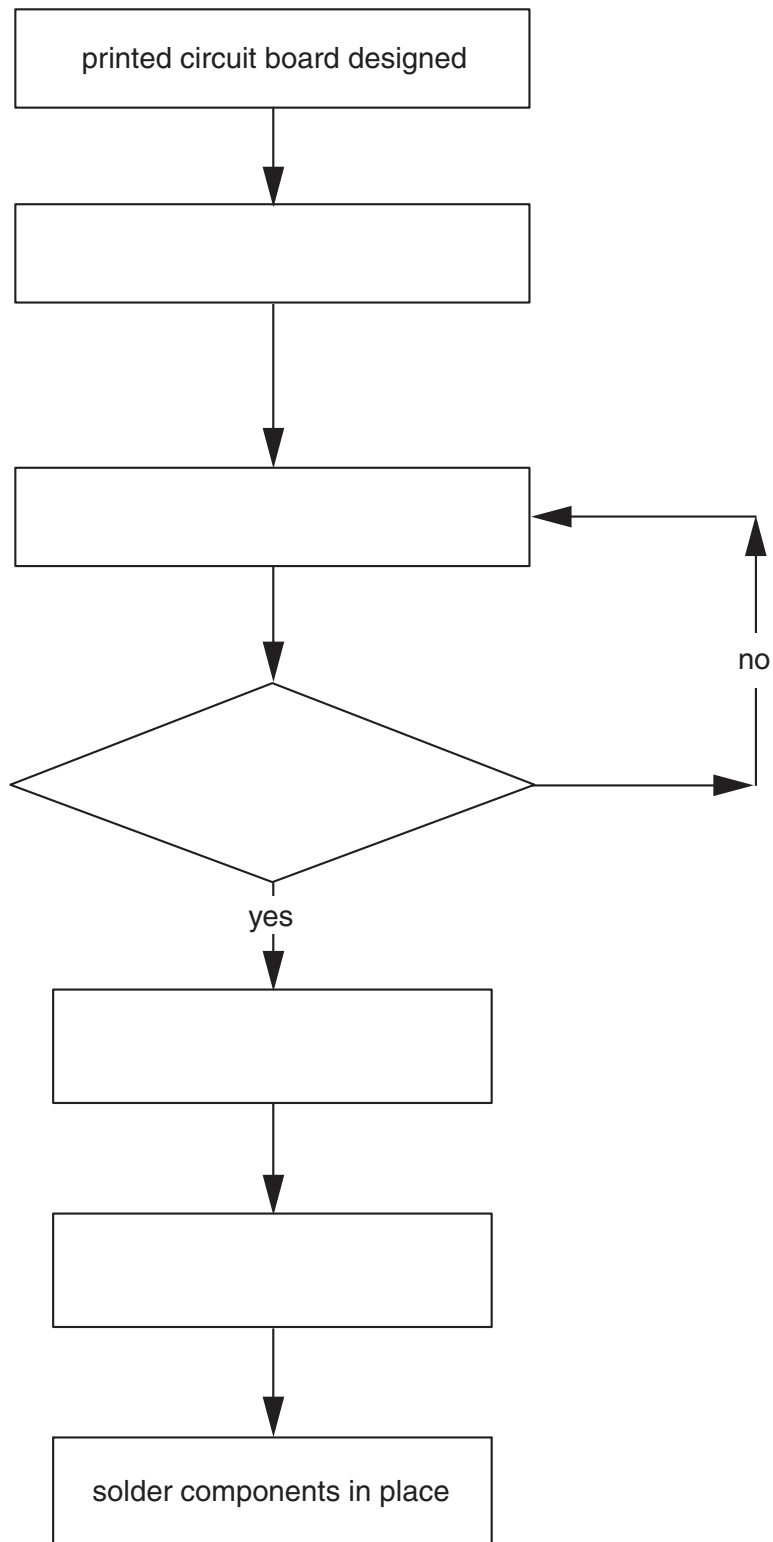

Fig. 3

[6]

(c) Another student wishes to make a burglar alarm to fit inside a guitar case. The alarm will trigger when the case is picked up. It can only be switched on or off using a key switch.

(i) Name a suitable simple device that can be used to trigger the alarm when the guitar case is moved.

..... [1]

(ii) Use sketches and notes to describe how this device works.

[4]

(iii) Fig. 4 below shows an incomplete circuit for the alarm. Complete Fig. 4 to show a suitable audio signal alarm.

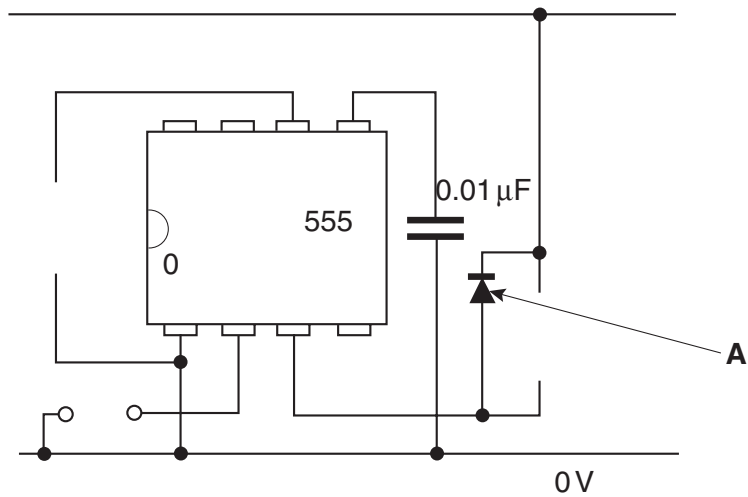

Fig. 4

[6]

(iv) Identify the component labelled A in the circuit shown in Fig. 4.

..... [1]

(v) Explain the purpose of component **A** in the circuit shown in Fig. 4.

.....
.....
.....
..... [3]

(vi) Describe how the student can avoid damaging the 555 timer IC when soldering it onto a printed circuit board.

.....
.....
.....
..... [2]

2 Fig. 5 shows part of a guitar tuning system.

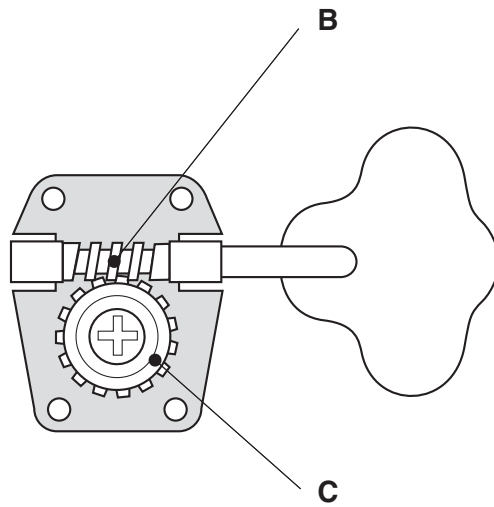

Fig. 5

(a) (i) Name the mechanism used to tighten or loosen the guitar strings.

..... [1]

(ii) Name the parts of the mechanism labelled **B** and **C**.

B [1]

C [1]

(iii) Explain why this mechanism is suitable for this application.

.....
.....
.....
..... [2]

(iv) Describe the motion conversion that takes place when the mechanism is operated.

.....
.....
.....
..... [2]

(b) Fig. 6 shows a folding stand for an electronic keyboard.

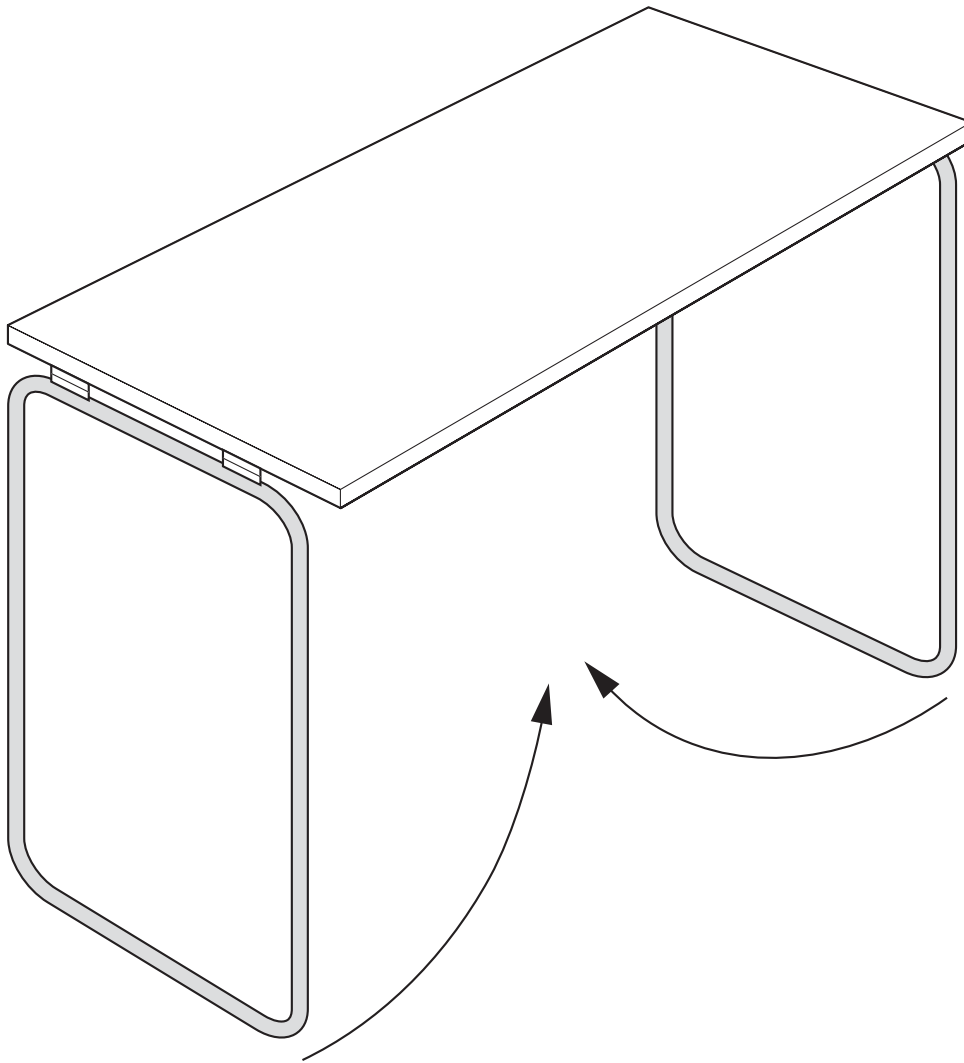

Fig. 6

(i) Show how levers and linkages can be used to lock the frame into the open position.

[3]

(ii) Explain what is meant by the term "moment".

.....

.....

..... [2]

(iii) Fig. 7 shows part of a linkage.

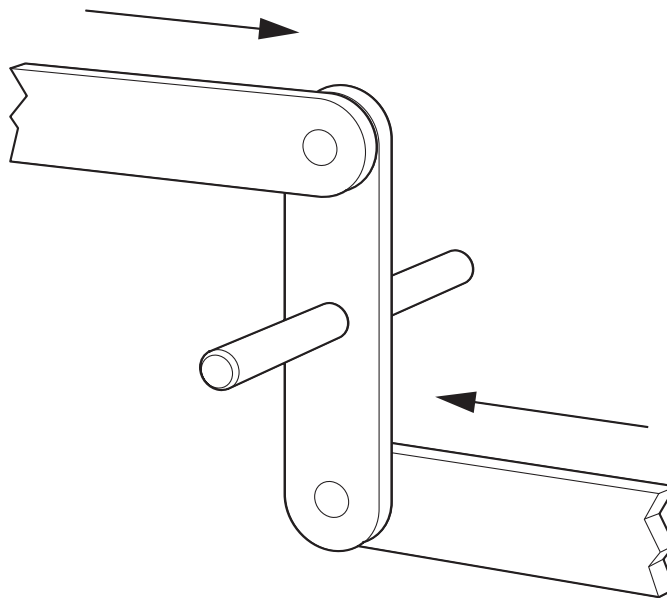

Fig. 7

Label the following parts on Fig. 7:

input; output; fixed pivot; moving pivot. [4]

(iv) Give an example of a class 2 lever.

..... [1]

(v) Describe **one** way in which a linkage can be modelled before it is manufactured.

.....

.....

.....

..... [2]

- (c) A cam could be used as a locking mechanism. Use sketches and notes to show how a cam can be used in this way.

[4]

- (d) Another type of locking device is a ratchet and pawl. Fig. 8 shows a diagram of a ratchet and pawl.

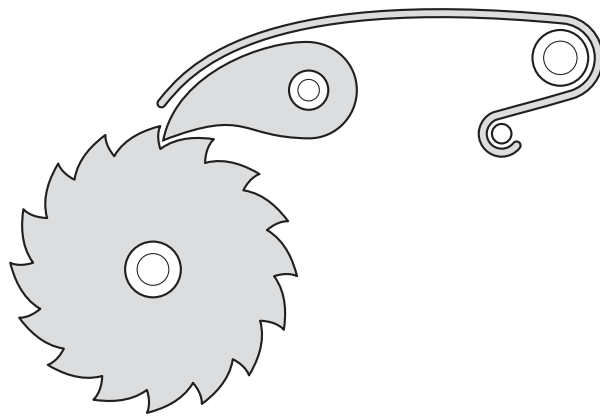

Fig. 8

- (i) Add labels to Fig. 8 to show the following:
ratchet; pawl; spring; direction of free rotation. [4]

- (ii) Give an example of the use of a ratchet and pawl.
.....
..... [1]

- (iii) Suggest **one** way in which the locking action of the ratchet and pawl could be released when necessary.
.....
.....
..... [2]

BLANK PAGE

- 3 (a) Fig. 9 shows a simplified diagram of the keyboard and its stand.

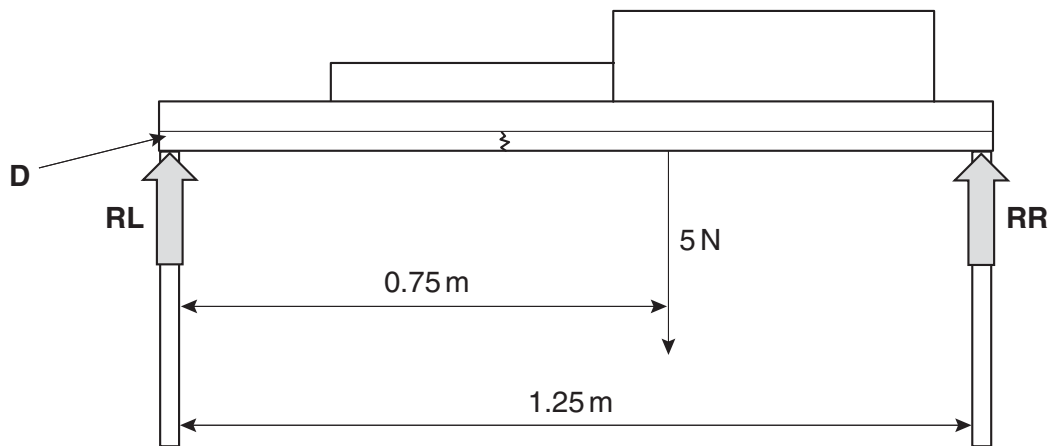

Fig. 9

- (i) Calculate the reactions, **RL** & **RR**, of the stand.

[4]

- (ii) Fig. 10 shows part of the stand and how it deflects when loaded.

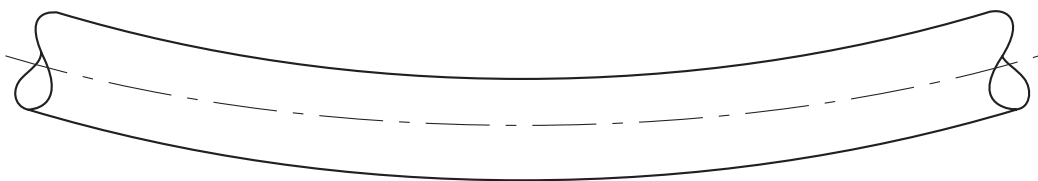

Fig. 10

Add labels to Fig. 10 to show:

tension; compression; neutral axis.

[3]

(iii) Sketch a suitable cross-section for the material used to make the stand.

[2]

(iv) The stand is broken across member **D** as shown in Fig. 9. Use sketches and notes to show **one** way that could be used to repair the cross member.

[3]

(v) A student wishes to measure the deflection of member **D** after it has been repaired. State **one** way that the deflection could be measured accurately.

.....

.....

.....

..... [2]

(b) Fig. 11 shows a graph of load against extension for a metal.

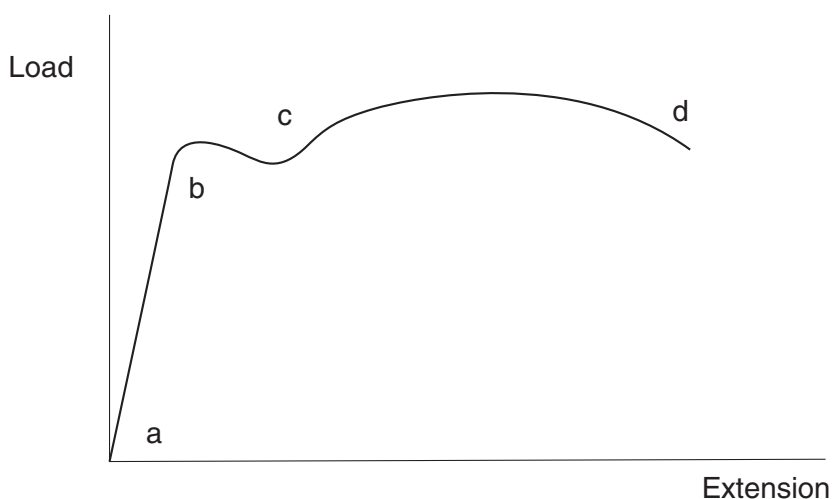

Fig. 11

(i) Explain what is happening to the material between points 'a' and 'b'.

.....

 [2]

(ii) Explain what happens to the material between points 'b' and 'c'.

.....

 [2]

(iii) The region between points 'c' and 'd' is called the "plastic region". State what happens to the material in this region.

.....

 [2]

(iv) State what happens at point 'd'.

.....
 [1]

(c) When a material is loaded it is said to be under stress and strain.

(i) Explain what is meant by the term stress.

.....
.....
.....
..... [2]

(ii) Explain **one** way that stress can be reduced when designing a structural member.

.....
.....
.....
..... [2]

(iii) Strain is a measure of the ratio of change of length compared to the original length of a member.

If a member is originally 2 m long and reduces by 4 mm on loading, calculate the strain for this member.

[3]

(iv) Explain what is meant by the term redundant member.

.....
.....
.....
..... [2]

- 4 Fig. 12 shows a design for a music stand to be used for school concerts.

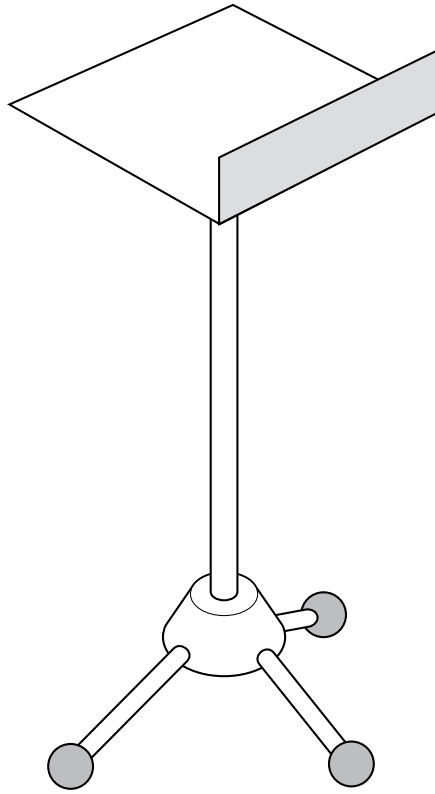

Fig. 12

- (a) There are several faults with this design. The music teacher asks a student to modify the design so that it will fulfil the following design requirements:
- the stand must be collapsible;
 - it must be adjustable to suit different students' heights;
 - it must have a low intensity light attached;
 - it must be stable in use.
- (i) use sketches and notes to show a method of collapsing the stand.

(ii) Use sketches and notes to show how the stand could be made height adjustable.

[3]

(b) LED's could provide low intensity lighting for the stands.

(i) Give **one** benefit of using these lighting devices.

..... [1]

(ii) A battery would power the light. Explain the difference between a battery and a cell.

.....
.....
.....
..... [2]



(iii) Give **one** benefit and **one** drawback in using a battery as the power source.

Benefit:
..... [1]

Drawback:
..... [1]

(iv) Draw and label a simple lighting circuit that can be switched on and off.

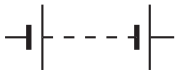
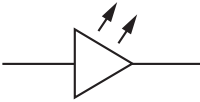
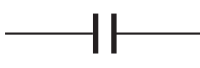
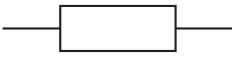
Select from the components listed below to design your circuit.

component	circuit symbol
9V battery	
LED	
capacitor	
resistor	
SPST switch	
PTM switch	

Draw your circuit here:

_____ +9V

_____ 0V

[5]

(c) The lighting system would need to be removable to aid storage.

Fig. 13 shows a design for a lighting enclosure that holds the circuit and a 9 v battery.

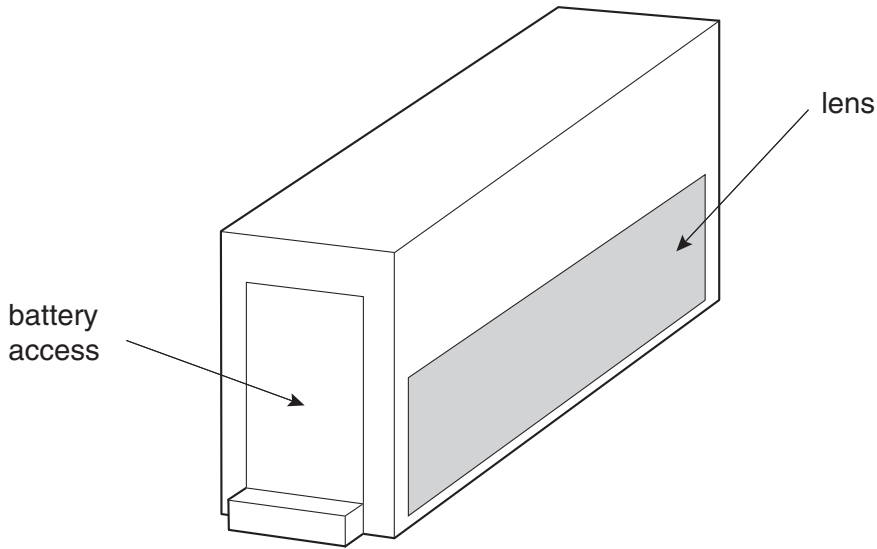

Fig. 13

(i) Add sketches and labels to Fig. 13 to show a way of temporary attachment of the enclosure to the music stand. [4]

(ii) Describe **three** main design requirements for the light enclosure that would need to be considered.

1. [2]

2. [2]

3. [2]

(d) It is decided to batch produce the stands in sets of 25. In order to speed up production a series of jigs is made. Explain what is meant by the term jig in this situation.

..... [2]

