

Centre Number	Candidate Number	Name
---------------	------------------	------

UNIVERSITY OF CAMBRIDGE INTERNATIONAL EXAMINATIONS  
International General Certificate of Secondary Education

**DESIGN AND TECHNOLOGY**

**0445/04**

Paper 4 Technology

May/June 2004

**1 hour**

Candidates answer on the Question Paper.  
No additional materials are required.

**To be taken together with Paper 1 in one session of 2 hours 45 minutes.**

**READ THESE INSTRUCTIONS FIRST**

Write your Centre number, candidate number and name on all the work you hand in.  
Write in dark blue or black pen in the spaces provided on the Question Paper.  
You may use a soft pencil for any diagrams, graphs or rough working.  
Do not use staples, paper clips, highlighters, glue or correction fluid.

Answer any **two** questions.  
The number of marks is given in brackets [ ] at the end of each question or part question.  
You may use a calculator.

FOR EXAMINER'S USE	
1	
2	
3	
4	
<b>TOTAL</b>	

If you have been given a label, look at the details. If any details are incorrect or missing, please fill in your correct details in the space given at the top of this page.

Stick your personal label here, if provided.

This document consists of **17** printed pages and **3** blank pages.



Fig. 1 shows a glasshouse, garden furniture and gardening equipment.

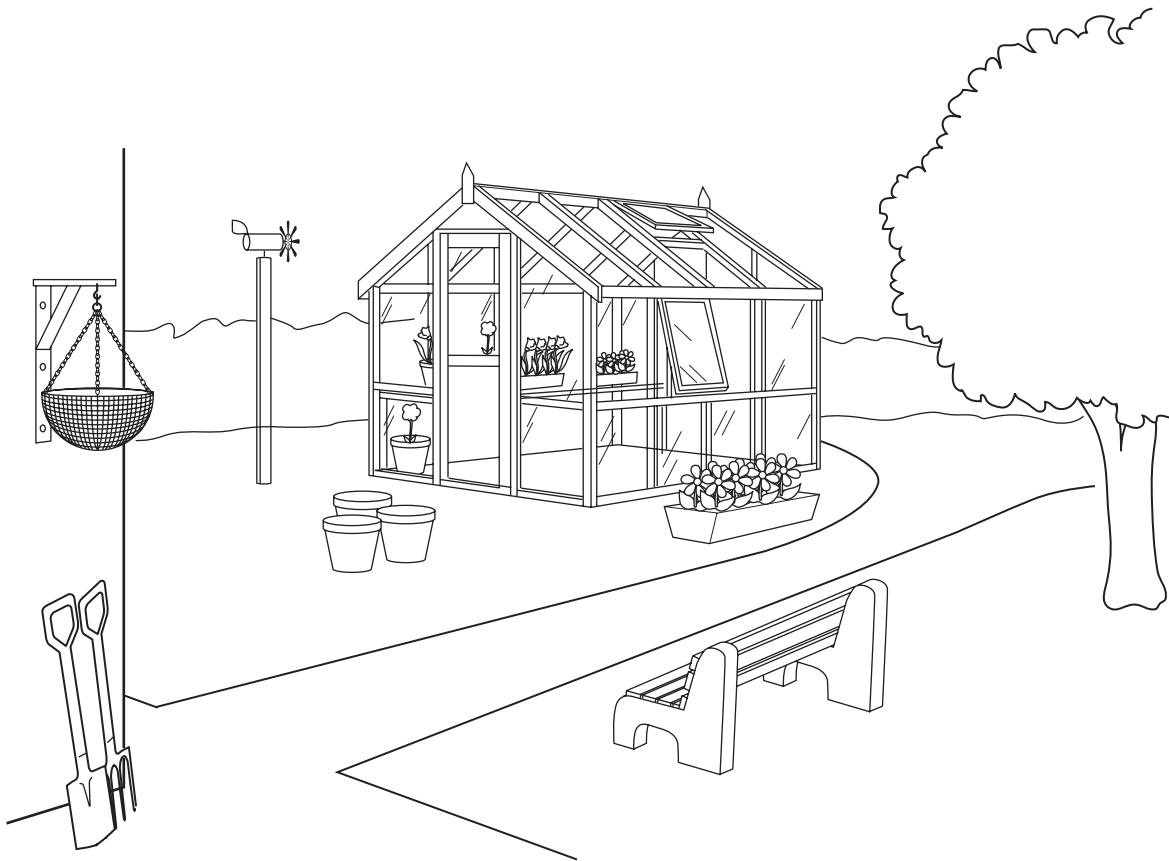

Fig. 1

- 1 (a) A wind powered generator is used to charge the batteries needed to power a watering system for the glasshouse.

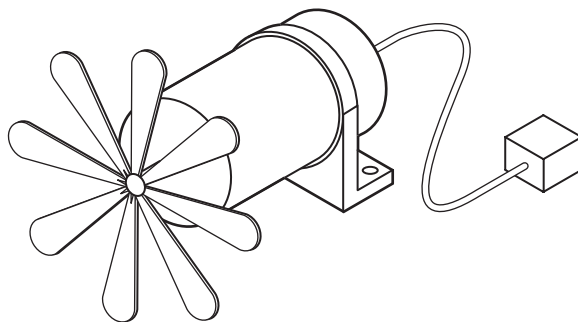
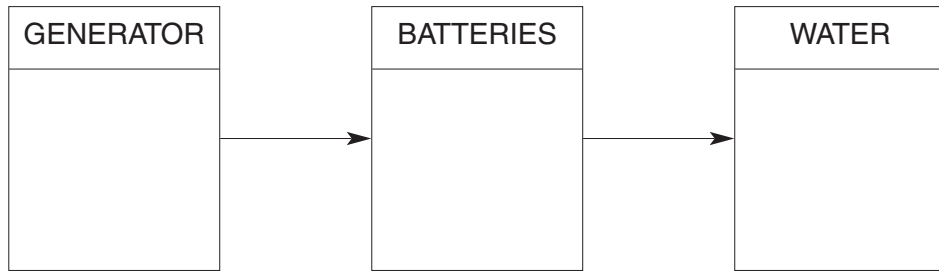

Fig. 2

- (i) Complete the block diagram below to show the energy conversions that take place when the watering system is in use.



[3]

- (ii) State **one** benefit of using the above system instead of mains electricity.

.....  
 .....[2]

- (iii) State **one** drawback of using the above system instead of mains electricity.

.....  
 .....[2]

- (iv) Circle the word from the list given below that best describes a battery as an energy source.

**Secondary**                      **Direct**                      **Natural**                      [1]

- (v) Explain how the wind powered generator could be improved to make it more energy efficient.

.....  
 .....  
 .....  
 .....[2]

- (b) (i) During a storm, the wind powered generator sways on its pole. Explain, using labelled sketches, how this could be prevented.

- (ii) The deflection of the pole is to be measured. State **one** device that could be used to measure deflection **accurately**.

.....  
 .....[1]

(iii) Sketch and label the device used to measure deflection that you have named in part(b)(ii).

[3]

(iv) When the pole is deflected it is said to experience a moment. Explain the term 'moment'.

.....





.....

.....

[3]

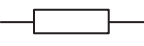
(c) The watering system for the glasshouse has a safety cut-off device to prevent watering the plants too much.

(i) Using the components shown in the table below, complete the circuit diagram in Fig. 3.

component name	component symbol
resistor	
variable resistor	
diode	
relay	

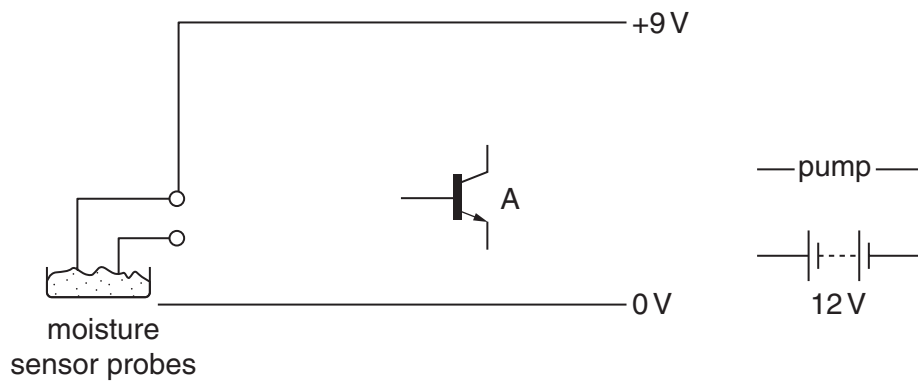

[5]

Fig. 3

(ii) The circuit shown in Fig. 3 is produced by soldering components onto a printed circuit board.

Explain **one** way of preventing damage to component **A** when soldering it to the printed circuit board.

.....  
.....  
.....[2]

(iii) A 'mock-up' of the circuit shown in Fig. 3 was made. Describe **one** way of mocking-up a circuit.

.....  
.....  
.....  
.....[2]

(iv) Give **one** benefit of mocking-up a circuit before soldering components to a printed circuit board.

.....  
.....[1]

2 Fig. 4 shows details of a hanging basket and bracket.

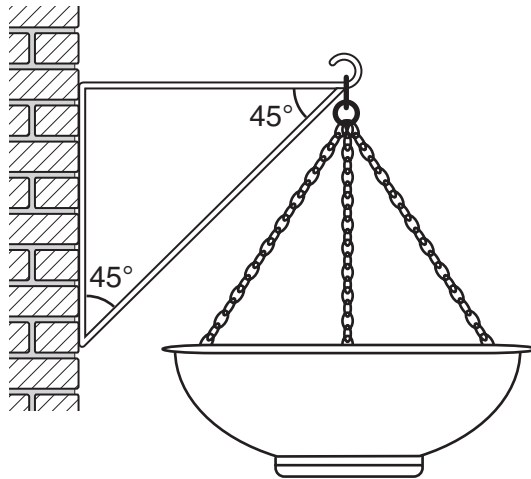

Fig. 4

(a) (i) Add labels to Fig. 4 to show which member of the bracket is in tension and which member is in compression. [2]

(ii) The weight of the basket is 200 N. Determine the forces in the members of the bracket.

[3]

(iii) Explain the term 'redundant member' in a structure.

.....  
 ..... [2]

(iv) The bracket is made from mild steel and is joined by welding.

Give **one** benefit to the manufacturer of joining the bracket in this way.

.....  
 ..... [1]

Give **one** benefit to the user of joining the bracket in this way.

.....  
 ..... [1]

- (v) Using a gusset plate could strengthen the bracket joints. Show, using labelled sketches, what is meant by a 'gusset plate'

[3]

- (b) The bracket could be made from either solid mild steel bar or from mild steel tube. Complete the table below.

bracket section	Diagram (cross-section)	Reason for use
mild steel bar		
mild steel tube		light weight and easy to lift up when fixing to a wall.

[4]

(c) When designing the bracket the designer used a stress/strain graph.

(i) Using the axes below draw a typical stress/strain graph for mild steel.  
Label the graph to identify the following key features:

- elastic region,
- plastic region,
- ultimate tensile stress,
- fracture stress.

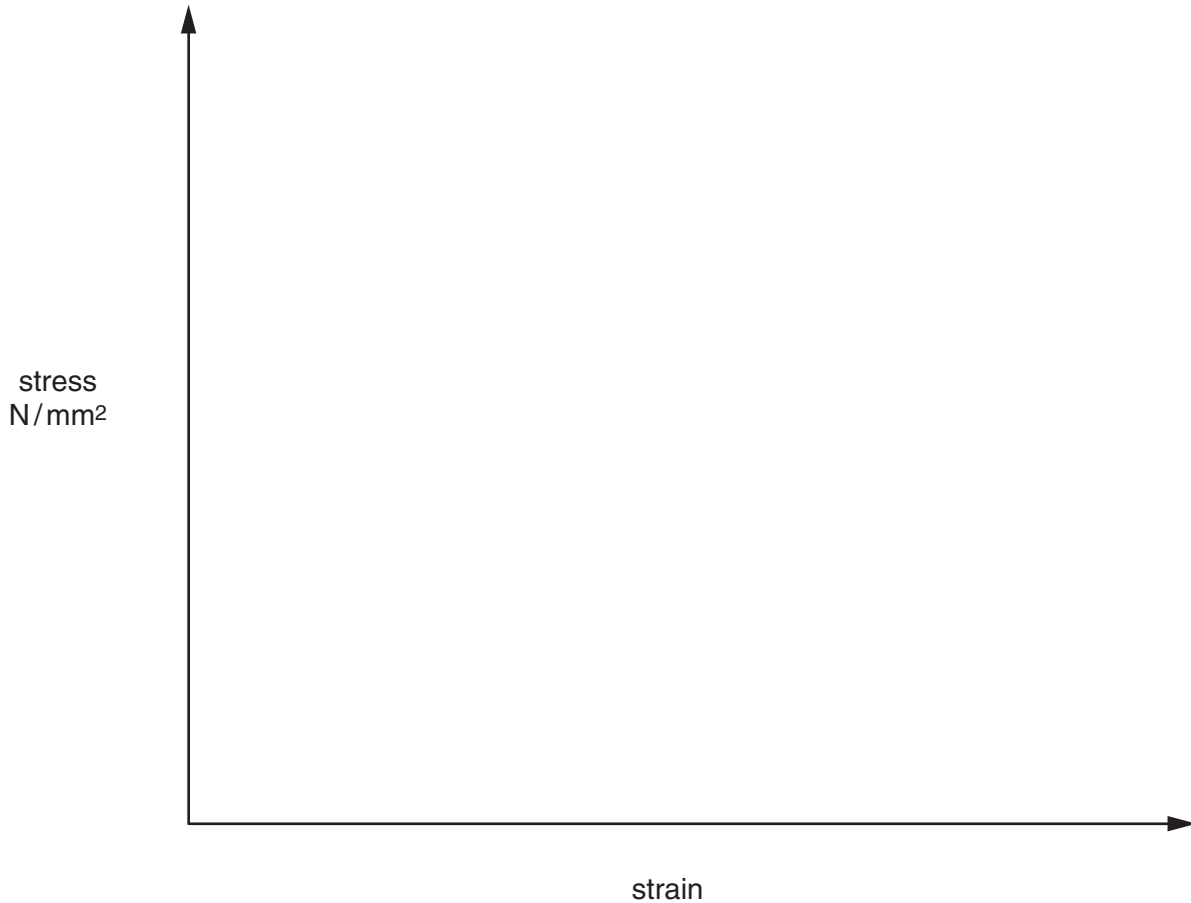

[6]

(ii) In a tensile test a mild steel specimen of diameter 10 mm is subjected to a load of 14 kN. Calculate the stress on the specimen.

[4]



- (iii) If the modulus of elasticity is  $210 \text{ kN/mm}^2$ , calculate the strain on the specimen.

[4]

3 Fig. 5 shows a gardener pushing a wheelbarrow.

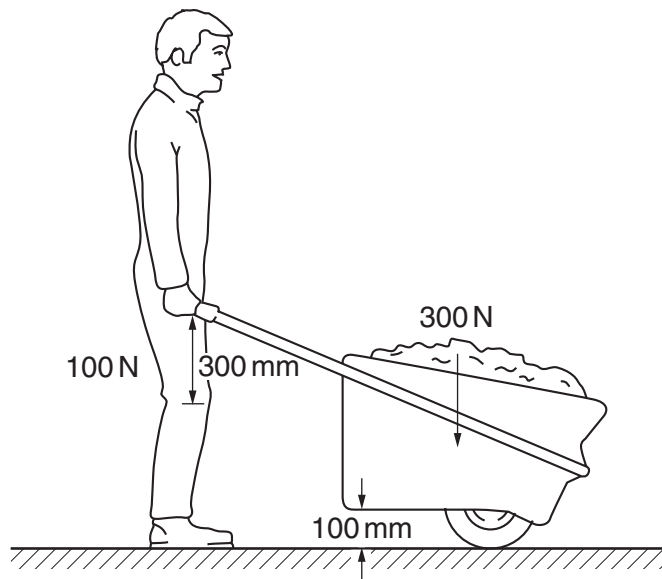

Fig. 5

(a) (i) Label on Fig. 5 The following features:

- load,
- effort,
- fulcrum.

[3]

(ii) From the list below, circle the type of lever that a wheelbarrow represents:

first order                      second order                      third order

[1]

(iii) For the wheelbarrow shown, calculate the velocity ratio (VR).

[4]

(iv) State **one** way that lifting the load could be made easier for the gardener.

.....

.....[1]

(v) Give **one** other example of a gardening tool that uses leverage.

.....  
.....[1]

(b) A drip-feed watering system is to be used to water plants in the glasshouse. An eccentric cam will be used to control the flow of the water.

Use sketches and notes to show how an eccentric cam could be used in this way.

[6]

(c) State a suitable material from which to make the cam. Give **one** reason for your choice.

Material: .....[1]

Reason for choice: .....[1]

(d) The glasshouse has an automatic fan light window to prevent overheating. The fan light is opened and closed by a worm gear system.

(i) Fig. 6 shows a worm gear system.

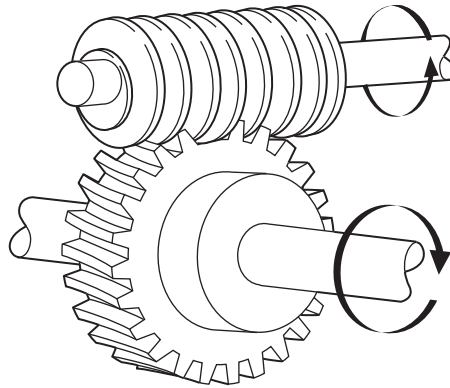

**Fig. 6**

Add labels to Fig. 6 to show the worm gear and the worm wheel. [2]

(ii) Give **two** benefits of using the worm gear system in this situation.

1 ..... [1]

2 ..... [1]

(iii) For the worm gear system shown the velocity ratio is 30:1. If the input speed is 120 rpm calculate the output speed.

[3]

- (iv) A rack and pinion could be used to open and close the fan light. Fig. 7 shows a rack and pinion.

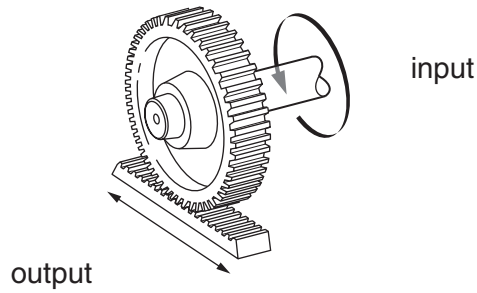

Fig. 7

Complete the block diagram below to show the motion conversions taking place during the operation of the rack and pinion.

input motion	output motion

[2]

- (v) Give **one** other example of the use of a rack and pinion.

.....  
 .....[1]

- (e) Fig. 8 shows a clutch as used in a motor lawnmower.

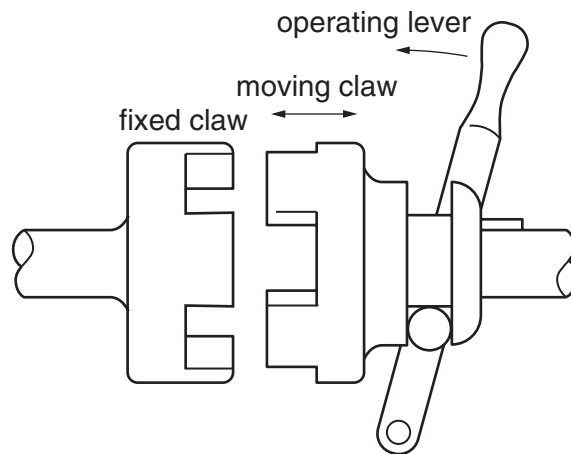

Fig. 8

Explain the purpose of a clutch in the operation of the lawnmower.

.....  
 .....  
 .....  
 .....[2]

- 4 The glasshouse has a frost alarm installed to alert the gardener to the danger of low temperature to the plants. Fig. 9 shows a diagram for an incomplete circuit for a frost alarm.

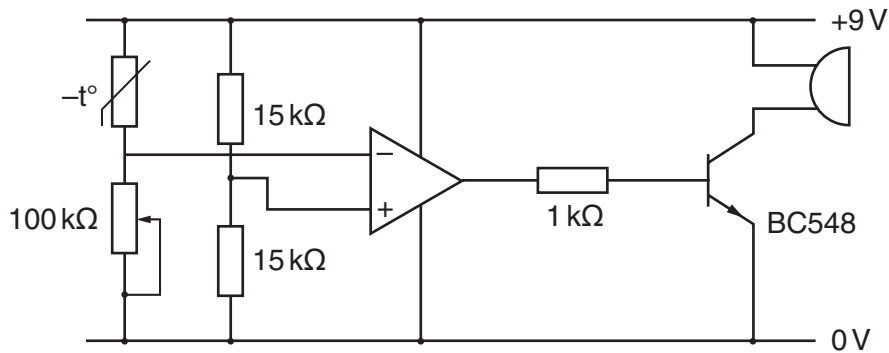

Fig. 9

- (a) (i) Draw a  $1\text{ M}\Omega$  feedback resistor on the circuit diagram in Fig. 9. [2]

- (ii) Explain the purpose of the  $100\text{ k}\Omega$  variable resistor in this circuit.

.....

.....

.....

.....[2]

- (iii) The pair of  $15\text{ k}\Omega$  resistors is a potential divider. Explain the term 'potential divider.'

.....

.....

.....

.....[2]

- (iv) The circuit could be modified to monitor high, instead of low temperatures. Explain how this can be done.

.....

.....

.....

.....[2]

- (v) An Integrated Circuit (IC) is used in this circuit. Give **one** benefit of using an Integrated Circuit in this situation.

.....

.....[1]

(vi) Integrated Circuits are delicate components. State **one** precaution that should be taken when connecting the IC to the circuit board.

.....  
 .....[1]

(b) The table below shows the colour coding system for resistor values.

colour	band 1	band 2	band 3	band 4
black	0	0	x1	red 2%
brown	1	1	x10	gold 5%
red	2	2	x100	silver 10%
orange	3	3	x1 000	
yellow	4	4	x10 000	
green	5	5	x100 000	
blue	6	6	x100 0000	
violet	7	7	x10 000 000	
grey	8	8	x100 000 000	
white	9	9	x1000 000 000	

(i) Label the colours for Fig. 10 to show a 470 Ω resistor with a tolerance of 10%.

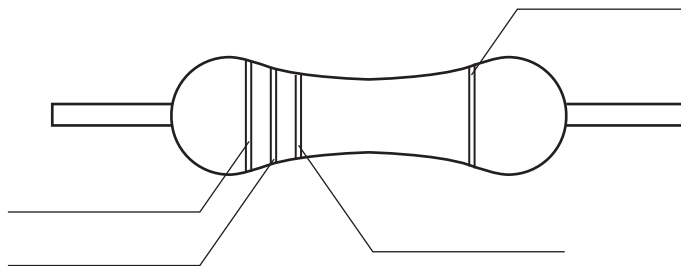

Fig. 10

(ii) Explain the term 'tolerance' in this situation.

.....  
 .....  
 .....  
 .....[2]

(iii) Fig. 11 shows two methods of connecting resistors. Name each method.

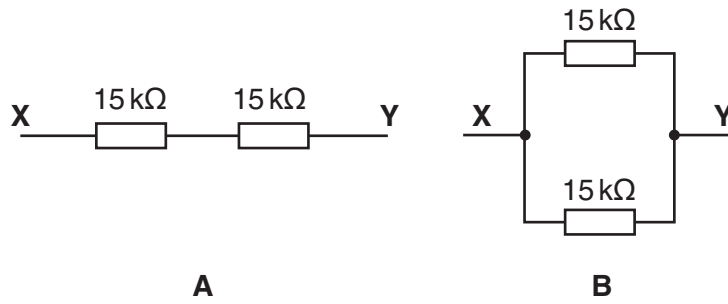

Fig. 11

Method A .....[1]

Method B .....[1]

(iv) Calculate the value of the total resistance for method B.

[3]

(c) When the alarm is activated it is required to 'latch on'.

(i) Explain the term 'latch on'.

.....

.....

.....

.....[2]



(ii) Show, by completing Fig. 12, how a relay could be used to latch the circuit below.

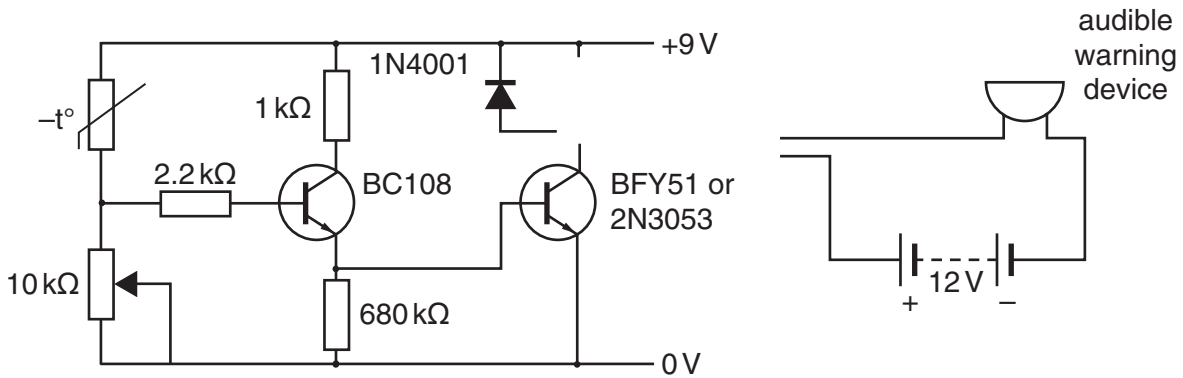

Fig. 12

[4]

(iii) Name the component used in the circuit shown in Fig. 12 to alter the sensitivity of the circuit.

.....  
 .....[1]

(iv) The circuit uses a buzzer. A buzzer is an electromagnetic device. Explain the term 'electromagnetic device'.

.....  
 .....  
 .....  
 .....[2]

(d) Circuits are designed using block diagrams.

(i) Complete the block diagram below for the frost alarm circuit.

	input		output
function	heat sensor	amplifier	
component		darlington-pair transistor circuit	buzzer

[3]

(ii) Name another type of output device that could be used in this circuit.

.....[1]





