

1 A sketch plan of the *OCEAN HOSPITAL* is given to the right. Given below is an incomplete view of a notice board to be placed at the entrance to the hospital in the position indicated on the sketch.

Using instruments, complete the view of the notice board below by:

- (a) drawing a logo for the hospital, made up from the two letters *O* and *H*, in the square indicated. Marks will be given for design sketches. [10]
- (b) drawing a diagram showing the layout of the hospital which will help visitors find their way about. Include arrows showing the way round the traffic island to the car park. [16]
- (c) printing *CAR PARK* and *MEDICAL WARDS* in appropriate positions on your diagram. [4]

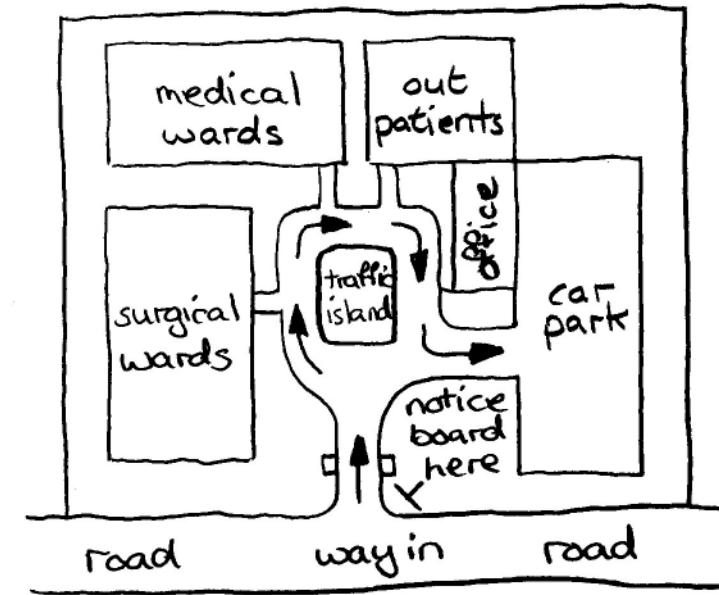

DRAW YOUR DESIGN SKETCHES FOR (a) HERE

ANSWER (b) AND (c) HERE

DRAW LOGO
IN THIS
SQUARE

DRAW YOUR DESIGN SKETCHES HERE

2 An electricity-producing company called *ENEDEX* is to place an advertisement in a newspaper giving details of its sources of energy in 2003.

You are required to complete the advertisement started at the bottom of the page by:

- (a) using any accurate method to draw an enlarged view of the trademark of the company in the space indicated. The trademark consists of an ellipse with a symbol in it as shown in the smaller view given. The centre lines and the positions of the top, bottom and sides of the ellipse are given. [13]

- (b) drawing a suitable graph, chart or diagram to illustrate the following figures:

Source of Energy	Percentage of Total
Water	32.5
Oil	40
Coal	15
Wind	12.5

- (c) using suitably positioned symbols on your illustration to represent each of the four sources of energy. Marks will be given for design sketches of the symbols. [6]

Do not colour your answer.

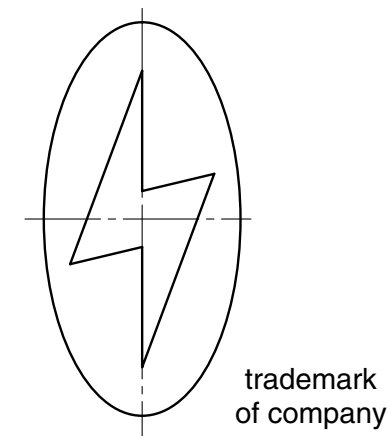

ANSWER (a) HERE

ANSWER (b) AND (c) HERE

ENEDEX

3 A hanging basket is shown in the sketch. An incomplete plan of the basket, drawn to a scale of 1:10 is given below.

(a) Give the geometrical name for the container of the basket.

..... [3]

(b) Project a front view of the basket, including the support wires, above the given plan. Do **not** draw the holes in the basket. [8]

(c) Use a geometrical method to find the true length of one of the support wires and print your answer in the box provided. [4]

(d) The container of the hanging basket is made of eight thin panels. Use a geometrical construction to draw the true shape of **one** of the panels. [4]

(e) There is a 300 mm diameter hole in each panel. The centre of the hole is at the intersection of the lines which bisect the three angles of the triangle. Use a geometrical construction to draw the hole in **one only** of the panels on the given plan. [11]

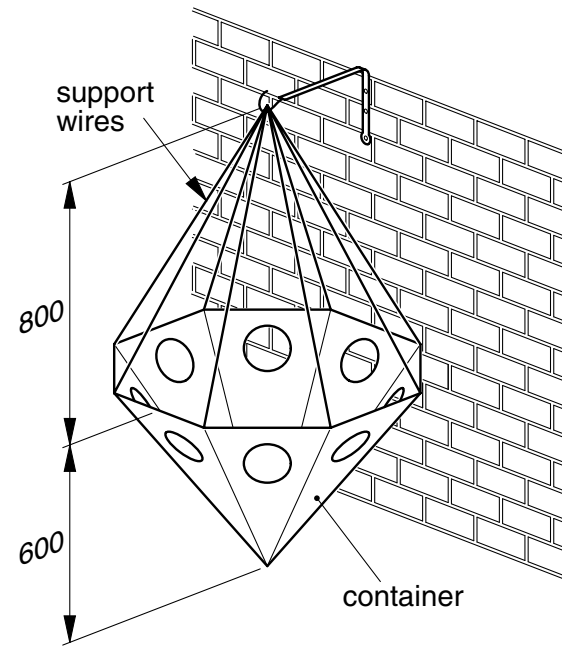

TRUE LENGTH OF SUPPORT WIRE

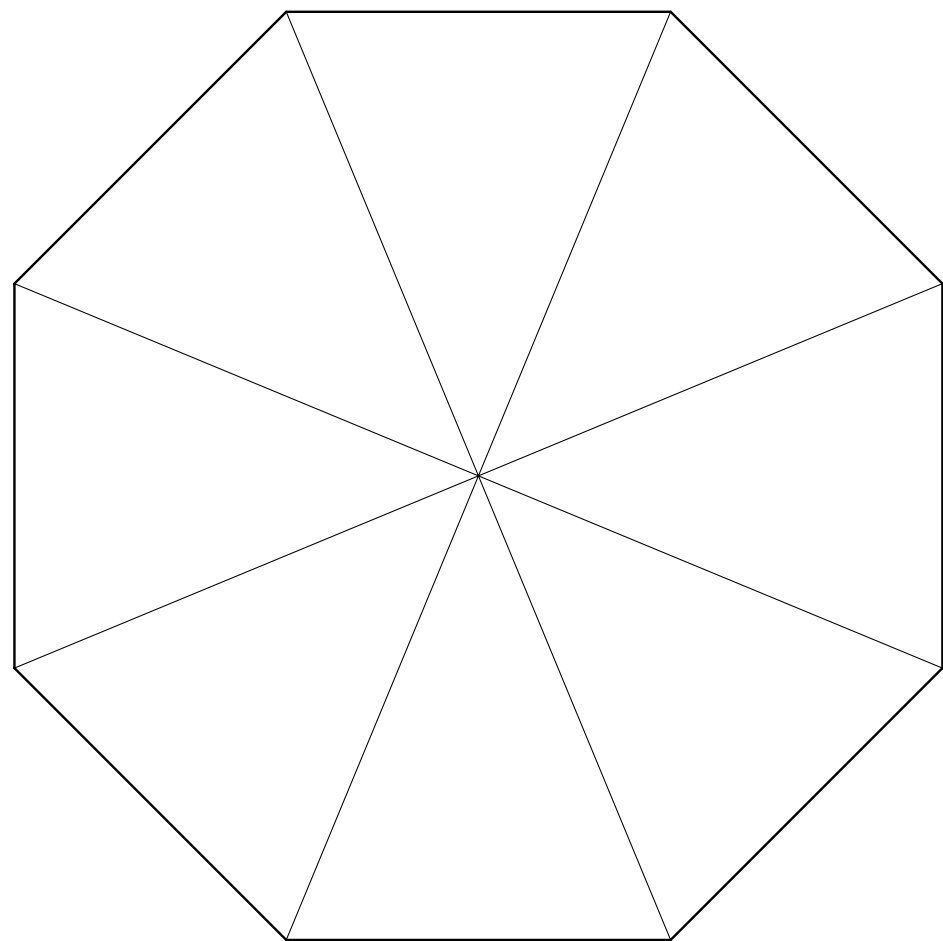

4 A wooden base is needed to hold a salt, a pepper and a mustard pot. Orthographic views of the pots are given to the right. The salt and pepper pots are the same size and shape.

In the positions indicated:

(a) design a suitable wooden base to hold the three pots; [4]

(b) **sketch freehand**, approximately full size, an **isometric view** of your chosen design for the base with the three pots in it; [20]

(c) colour and shade:

(i) the base to show that it is made from wood; [3]

(ii) the mustard pot only to show that it is made from shiny plastics. [3]

ANSWER (a) HERE

ANSWER (b) HERE

MUSTARD

SALT / PEPPER

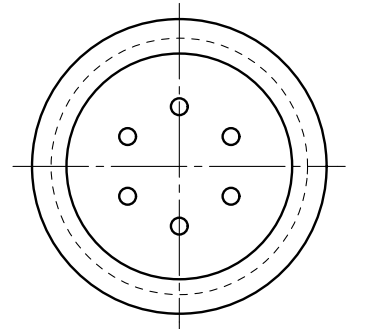
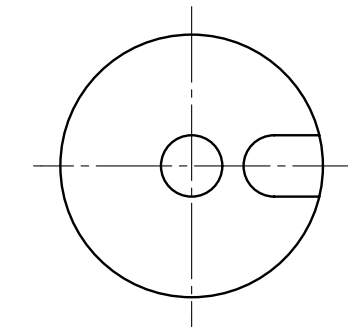
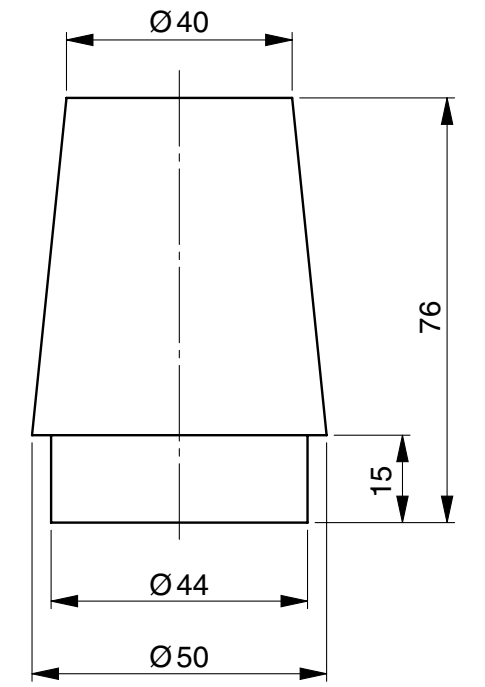
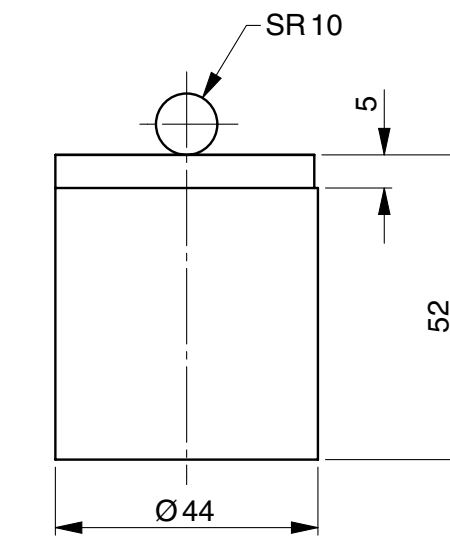

Copyright Acknowledgements:

Every reasonable effort has been made to trace all copyright holders. The publishers will be pleased to hear from anyone whose rights we have unwittingly infringed.

University of Cambridge International Examinations is part of the University of Cambridge Local Examinations Syndicate (UCLES), which is itself a department of the University of Cambridge.