



UNIVERSITY OF CAMBRIDGE INTERNATIONAL EXAMINATIONS
International General Certificate of Secondary Education

CANDIDATE
NAME

CENTRE
NUMBER

--	--	--	--	--

CANDIDATE
NUMBER

--	--	--	--



DESIGN AND TECHNOLOGY

0445/04

Paper 4 Systems and Control

May/June 2009

1 hour

Candidates answer on the Question Paper.

No Additional Materials are required.

To be taken together with Paper 1 in one session of 2 hours and 15 minutes.

READ THESE INSTRUCTIONS FIRST

Write your Centre number, candidate number and name on all the work you hand in.

Write in dark blue or black pen.

You may use a soft pencil for any diagrams or graphs.

Do not use staples, paper clips, highlighters, glue or correction fluid.

DO NOT WRITE IN ANY BARCODES.

You may use a calculator.

Section A

Answer **all** questions.

Section B

Answer **one** question.

At the end of the examination, fasten all your work securely together.

The number of marks is given in brackets [] at the end of each question or part question.

For Examiner's Use	
Section A	
Section B	
Total	

This document consists of **16** printed pages.



Section A

Answer **all** questions in this section.

1 Frameworks are one type of structure.

(a) (i) Give **one** example of a man-made framework.

..... [1]

(ii) Give **one** example of a natural framework.

..... [1]

(b) State the name of the other type of structure.

..... [1]

2 (a) Complete the statement below.

A strain gauge senses changes in [1]

(b) Give **one** specific example of a use for a strain gauge.

..... [1]

3 Fig. 1 shows a cross sectional diagram of electrical cable.

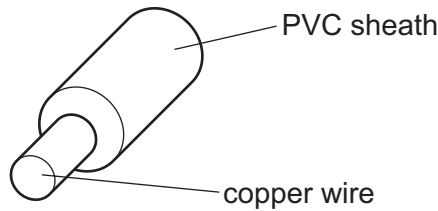

Fig. 1

State the electrical property of each material.

PVC [1]

Copper [1]

4 Fig. 2 shows a cranked handle.

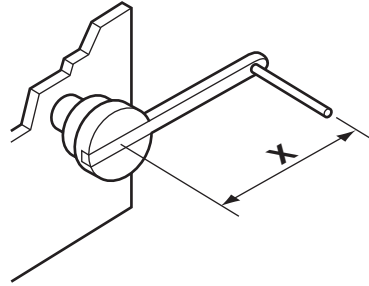

Fig. 2

Explain the term Mechanical Advantage (MA) for the cranked handle shown in Fig. 2.

.....

.....

.....

..... [2]

5 Sketch and label the circuit symbol for a light emitting diode.

[3]

6 A bevel gear system is a commonly used transmission system.

(a) Give **one** example of the use of a bevel gear system.

..... [1]

(b) Describe the motion conversion that takes place when a bevel gear system operates.

.....

.....

.....

..... [2]

7 Give **one** example of the use of logic gates in control systems.

..... [1]

8 'I' section beams are commonly used in building construction.

(a) Sketch an 'I' section beam.

[2]

(b) Explain briefly why the beam is shaped in this way.

.....
.....
.....
..... [2]

9 Fig. 3 shows a device used to accurately measure deflection in structures.

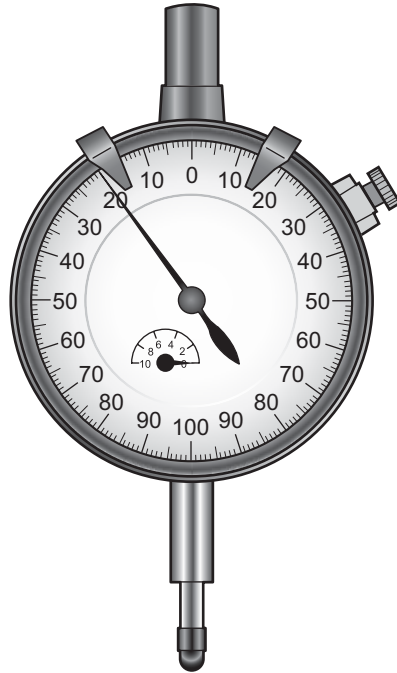

Fig. 3

Name the device shown in Fig. 3.

..... [1]

10 Electricity is measured in both voltage and current.

Explain these terms.

Voltage

.....

.....

..... [2]

Current

.....

.....

..... [2]

Section B

Answer **one** question from this section.

For
Examiner's
Use

11 Fig. 4 shows a circuit diagram for an audible alarm device.

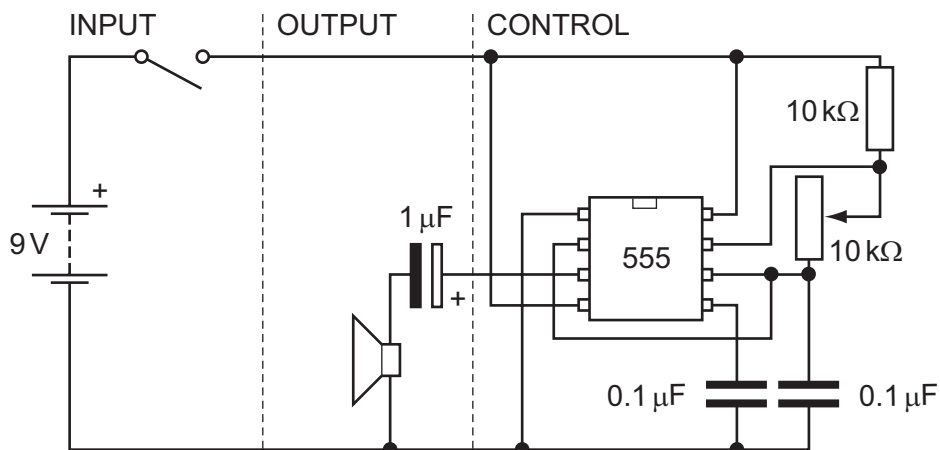

Fig. 4

(a) Explain how the circuit works.

.....

.....

.....

.....

.....

.....

.....

.....

..... [4]

(b) Label the 555 I.C. circuit symbol in Fig. 4 to show the pin numbers. [2]

(c) There are **two** types of capacitor shown in the circuit diagram.

Explain the difference between the two types of capacitor.

.....

.....

.....

.....

..... [3]

(d) Explain the function of the 10 kΩ variable resistor.

.....
.....
.....
..... [2]

(e) The circuit diagram shows a 9 V battery.

State how many cells make up a 9 V battery.

..... [1]

(f) The circuit is powered by a 9 V battery.

Describe how a battery works in terms of energy conversion.

.....
.....
.....
..... [2]

(g) A slide switch is used in the input part of the circuit.

(i) Sketch and label a slide switch.

[3]

(ii) Sketch the symbol for a toggle switch.

[2]

(iii) Explain how, by changing the type of input switch, the circuit could be used to sense someone entering a room.

.....

.....

.....

..... [3]

(h) Logic gates could be used to control the audible alarm.

Sketch and label a simple logic circuit that would activate the alarm when the input switch is 'on' and a light dependent resistor is 'off'.

[3]

- 12 Fig. 5 shows a black box diagram of a mechanism designed to convert one form of motion to another.

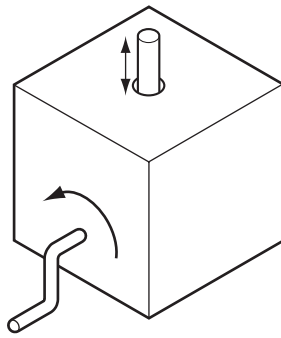

Fig. 5

- (a) Name the **two** forms of motion indicated on Fig. 5.

..... [1]

..... [1]

- (b) Sketch and label a cam and follower that could be used to perform this conversion.

[3]

(c) Fig. 6 shows a diagram of a snail cam and follower.

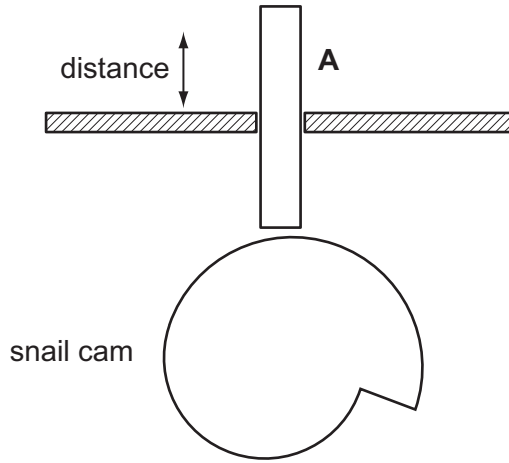

Fig. 6

(i) Describe the motion of the follower **A** for one revolution of the snail cam.

.....
.....
.....
..... [2]

(ii) Draw on Fig. 6 to show the direction of rotation of the snail cam.

[1]

(d) Mechanical transmission systems can be operated by the following methods.

- Chains and sprockets
- Pulleys and belts
- Gears

Complete the table below to show these methods giving benefits, drawbacks and **one** example of the use of each method.

Method	Benefit	Drawback	Example of use
Chains and sprockets			
Pulleys and belts			
Gears			

[9]

(e) In some situations it is important to stop a gear from moving backwards. In these cases a ratchet and pawl mechanism can be used.

(i) Use sketches and notes to show a ratchet and pawl mechanism.

[4]

(ii) Give **one** specific example of the use of a ratchet and pawl mechanism.

..... [1]

(f) Fig. 7 shows a gear system from a lawn mower.

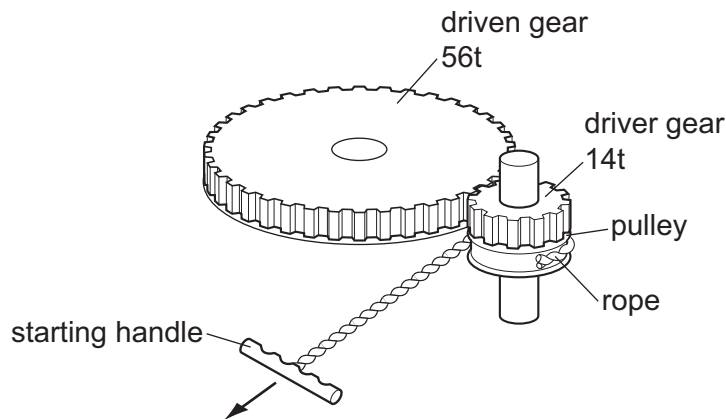

Fig. 7

Determine the velocity ratio (VR) for the system shown.

[3]

- 13 Fig. 8 shows an experiment to investigate the use of sheet materials to span a gap and carry a load.

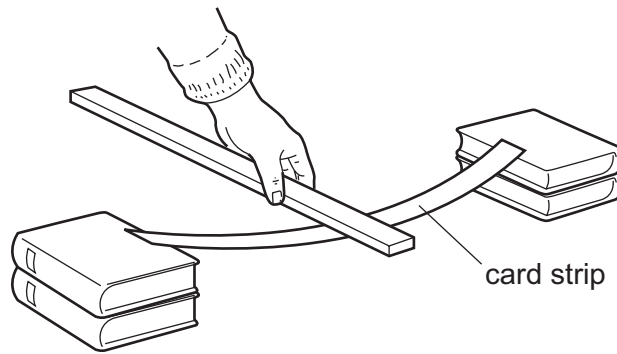

Fig. 8

- (a) Explain how the card strip can be modified, without adding any more materials, to enable it to support the load more effectively.

.....

.....

..... [2]

- (b) Fig. 9 shows a cutaway view of an internal door that has a cellular filling.

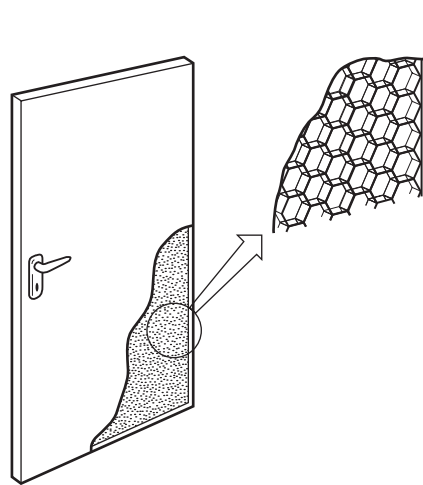

Fig. 9

- (i) Give **three** benefits of this type of door construction.

1 [1]

2 [1]

3 [1]

(ii) Name **one** other product that uses a similar type of construction.

..... [1]

(c) Fig. 10 shows an example of plastics food packaging.

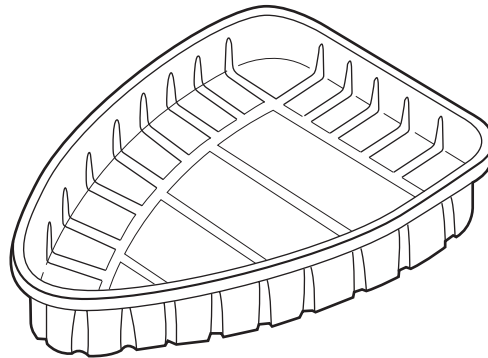

Fig. 10

Describe the structural features of this packaging.

.....
.....
..... [3]

(d) Fig. 11 shows members in a framework.

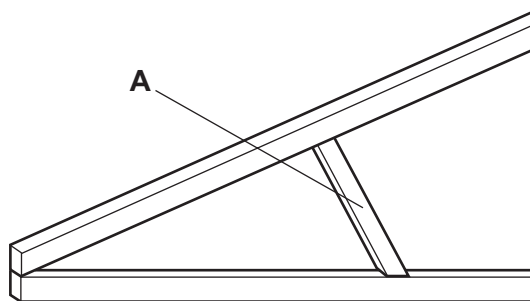

Fig. 11

(i) Name part **A** and explain its use in a framework.

.....
.....
.....
..... [3]

(ii) Use sketches and notes to show how the joints could be reinforced using gussets.

[3]

(iii) Give **one** benefit of using gussets to reinforce roofing trusses.

.....
.....

[1]

(e) Fig. 12 shows a suspension bridge.

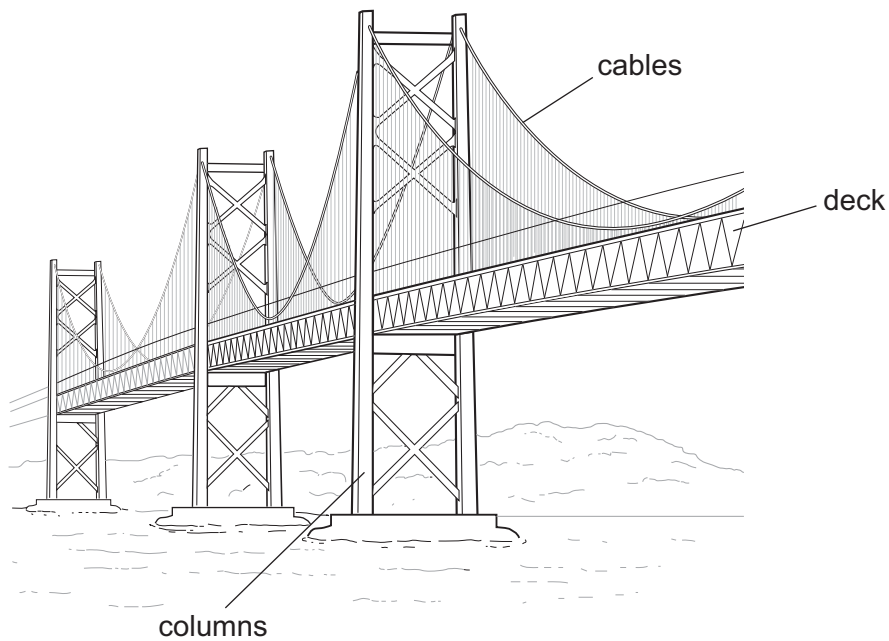

Fig. 12

(i) Complete the table below.

Member	Type of forces experienced	Failure
Cable	Tension	
Column		Buckling
Deck		

[4]

(ii) Name the type of loading that a bridge experiences.

..... [1]

(iii) Fig. 13 shows how the cables are joined to the columns with pins.

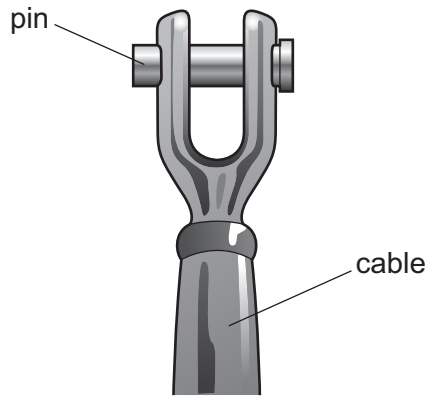

Fig. 13

Name the force acting on the pins.

..... [1]

(iv) The pins experience stress.

Explain how the effects of stress can be reduced on the pins.

.....

 [3]

Permission to reproduce items where third-party owned material protected by copyright is included has been sought and cleared where possible. Every reasonable effort has been made by the publisher (UCLES) to trace copyright holders, but if any items requiring clearance have unwittingly been included the publisher will be pleased to make amends at the earliest possible opportunity.

University of Cambridge International Examinations is part of the Cambridge Assessment Group. Cambridge Assessment is the brand name of University of Cambridge Local Examinations Syndicate (UCLES), which is itself a department of the University of Cambridge.