



UNIVERSITY OF CAMBRIDGE INTERNATIONAL EXAMINATIONS
International General Certificate of Secondary Education

CANDIDATE
NAME

CENTRE
NUMBER

--	--	--	--	--

CANDIDATE
NUMBER

--	--	--	--	--



DESIGN AND TECHNOLOGY

0445/31

Paper 3 Resistant Materials

October/November 2011

1 hour

Candidates answer on the Question Paper.

No Additional Materials are required.

To be taken together with Paper 1 in one session of 2 hours 15 minutes.

READ THESE INSTRUCTIONS FIRST

Write your Centre number, candidate number and name on all the work you hand in.

Write in blue or black pen.

You may use a soft pencil for any diagrams, graphs or rough working.

Do not use staples, paper clips, highlighters, glue or correction fluid.

DO **NOT** WRITE IN ANY BARCODES.

Section A

Answer **all** questions in this section.

Section B

Answer **one** question in this section.

You may use a calculator.

The total of the marks for this paper is 50.

The number of marks is given in brackets [] at the end of each question or part question.

For Examiner's Use	
Section A	
Section B	
Total	

This document consists of **14** printed pages and **2** blank pages.



Section A

Answer **all** questions in this section.

1 (a) Name the tool shown below.

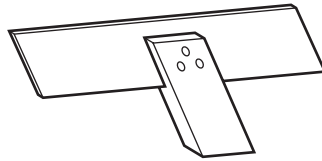

..... [1]

(b) State **one** use for the tool in (a).

..... [1]

2 (a) Name the process shown in Fig. 1.

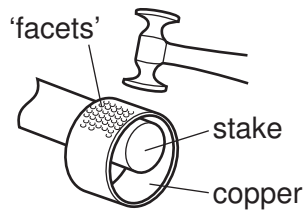

Fig. 1

..... [1]

(b) Give **two** reasons why the process would be carried out.

1 [1]

2 [1]

3 Name the **three** standard metal sections shown below.

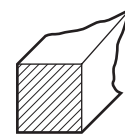
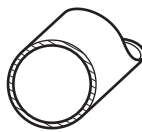
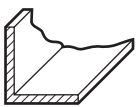

.....

.....

.....

[3]

4 Name the centre lathe operations shown below.

work rotates

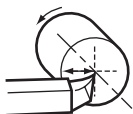

.....

work rotates

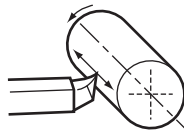

.....

work rotates

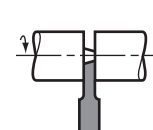

.....

[3]

- 5 Fig. 2a shows a scan fitting.
Complete Fig. 2b to show how a scan fitting could be used to join the rail and leg.

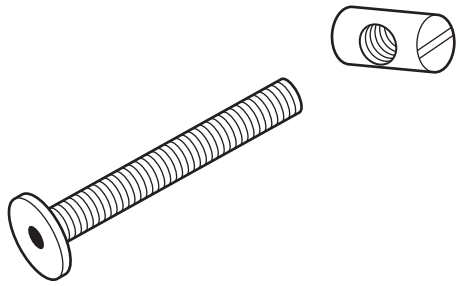

Fig. 2a

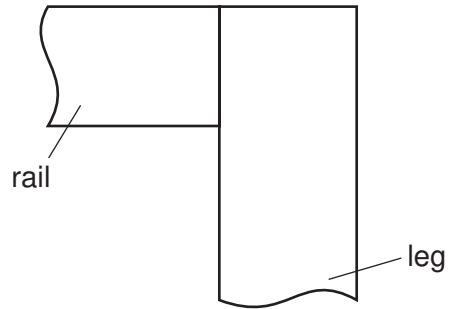

Fig. 2b

[3]

- 6 Complete the drawing below to show a coping saw.



[2]

- 7 Fig. 3 shows a prototype tray used to hold a DVD case. The tray has been vacuum formed.

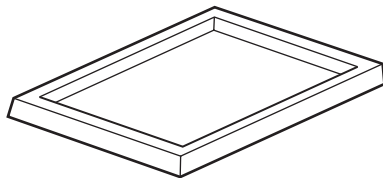
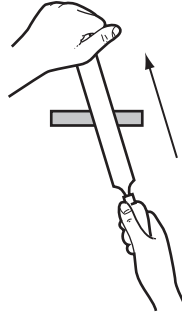

Fig. 3

Use sketches and notes to show a modification to the design of the tray to make it easier to remove the DVD case but still hold it securely.

[2]

8 Name the method of filing shown below.



..... [1]

9 Complete the drawing below to show an exploded view of a cross halving joint.

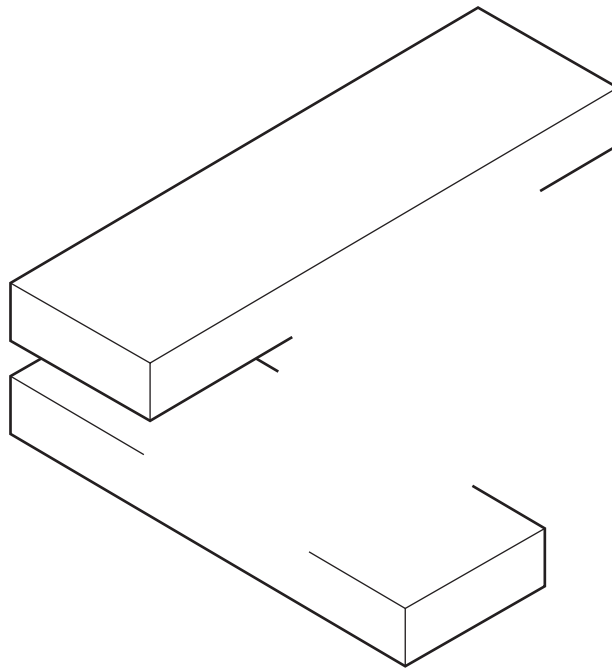

[3]

10 Name the parts of the wood turning lathe labelled **A**, **B** and **C** shown below.

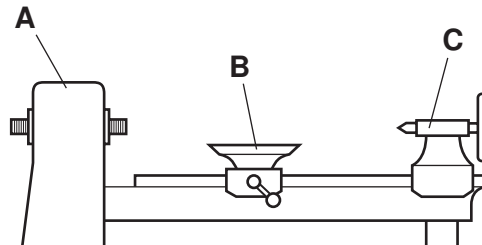

Part **A** [1]

Part **B** [1]

Part **C** [1]

Section B

Answer **one** question from this section.

11 Fig. 4 shows a design for a rabbit hutch. The rabbit hutch will be used outdoors.

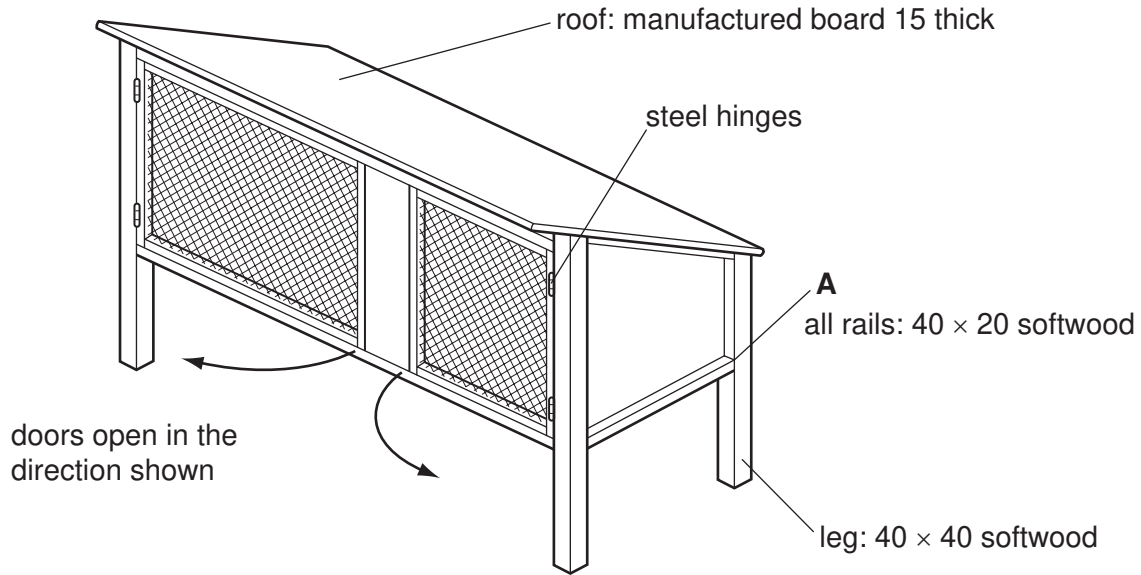

Fig. 4

(a) Sketch and name a suitable permanent joint at **A**.

[3]

Name of joint [1]

(b) (i) Name a suitable manufactured board for the roof of the rabbit hutch.

..... [1]

(ii) Give **one** reason why the roof of the rabbit hutch is sloping backwards.

..... [1]

- (iii) Use sketches and notes to show how the roof could be fixed to the rabbit hutch. Your method must allow the roof to be taken off for maintenance. Name any fittings used.

[3]

- (c) (i) Sketch and name a suitable hinge that could be used to join the doors to the rabbit hutch.

[3]

Name of hinge [1]

- (ii) State **one** disadvantage of using steel hinges outdoors.

..... [1]

(d) Fig. 5 shows one recess for a hinge marked out on a leg of the rabbit hutch.



Fig. 5

(i) Name **two** marking out tools, other than a pencil and rule, that could be used to mark out the recess.

1 [1]

2 [1]

(ii) Use sketches and notes to show how the recess could be cut out.
Name the tools used.

[4]

(e) Use sketches and notes to show how each door could be:

- secured in the closed position;
- prevented from swinging inwards.

[5]

12 Fig. 6 shows views of an incomplete design for a bracket used to support the net on a table tennis table.

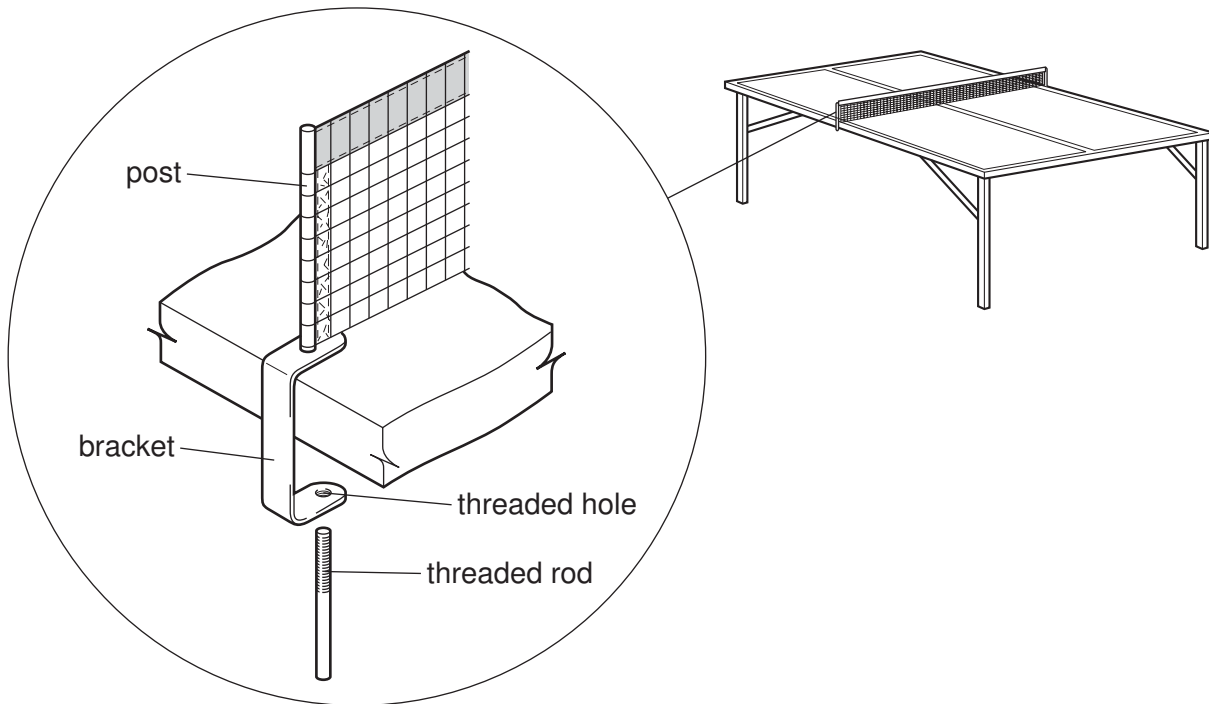

Fig. 6

(a) (i) Name a suitable ferrous metal for the bracket and rod.

..... [1]

(ii) Give a reason, other than strength, why a ferrous metal would be more suitable for the bracket and rod than a non-ferrous metal.

..... [1]

(iii) State a suitable thickness of the metal from which the bracket would be made.

..... [1]

(iv) State a suitable diameter for the threaded rod.

..... [1]

(b) Give **two** reasons why the metal for the bracket would be drilled **before** it is bent to shape.

1 [1]

2 [1]

(c) Use sketches and notes to show how:

(i) a thread could be cut in the hole in the bracket;

[4]

(ii) a thread could be cut on the rod.

[4]

(d) In use, the end of the threaded rod damages the underside of the table.
Use sketches and notes to show how this could be prevented.

[2]

- (e) In use, the threaded rod is difficult to tighten by hand.
Use sketches and notes to show how the threaded rod could be modified to make it easier to tighten.

[3]

- (f) Use sketches and notes to show how the post could be brazed into the bracket.
Include details of all the equipment used in the brazing process.

[6]

13 Fig. 7 shows a kitchen roll holder made mainly from 15 mm thick softwood.

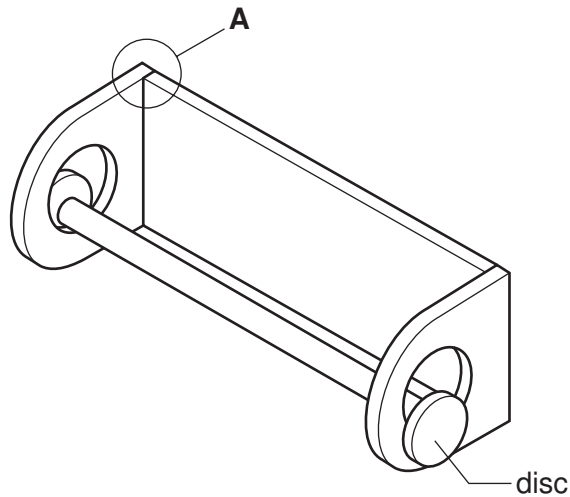

Fig. 7

(a) Fig. 8 shows parts of the kitchen roll holder marked out, ready to be cut, drilled and joined.



Fig. 8

Complete the table by naming the processes, tools and equipment required to make the kitchen roll holder.

Stage	Process	Tools and equipment
1	Mark out	
2	Drill a hole in each end	
3	Round the corners	
4		Tenon saw/bench hook
5	Square the sawn ends	
6		PVA adhesive

[6]

(b) Sketch and name a joint, other than a butt joint, that could be used at **A**.

[3]

Name of joint [1]

(c) Give a reason why the disc shown in Fig. 7 is smaller than the hole in the side of the kitchen roll holder.

..... [1]

(d) Fig. 9 shows a plastic kitchen roll holder.

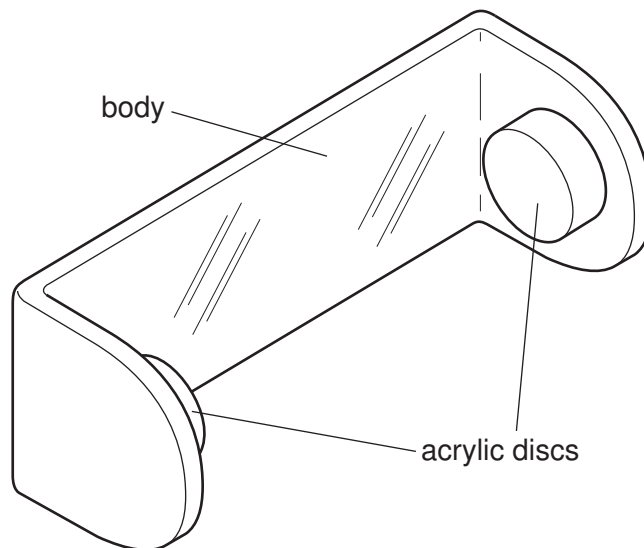

Fig. 9

- (i) Use sketches and notes to show how the body of the kitchen roll holder could be bent to shape from a single piece of acrylic.

[4]

- (ii) Use sketches and notes to show how the acrylic discs to support the kitchen roll could be made and joined to the body of the kitchen roll holder using acrylic cement.

[4]

(iii) State **two** safety precautions to be taken when using acrylic cement.

1 [1]

2 [1]

(e) Explain how the flexible property of acrylic has been used in the design of the plastic kitchen roll holder.

.....
.....
..... [2]

(f) The kitchen roll holder in Fig. 9 could also be made by injection moulding.
Explain why injection moulding is only suitable when making products in large quantities.

.....
.....
..... [2]

BLANK PAGE

Permission to reproduce items where third-party owned material protected by copyright is included has been sought and cleared where possible. Every reasonable effort has been made by the publisher (UCLES) to trace copyright holders, but if any items requiring clearance have unwittingly been included the publisher will be pleased to make amends at the earliest possible opportunity.

University of Cambridge International Examinations is part of the Cambridge Assessment Group. Cambridge Assessment is the brand name of University of Cambridge Local Examinations Syndicate (UCLES), which is itself a department of the University of Cambridge.