



UNIVERSITY OF CAMBRIDGE INTERNATIONAL EXAMINATIONS  
International General Certificate of Secondary Education

CANDIDATE  
NAME

CENTRE  
NUMBER

--	--	--	--	--

CANDIDATE  
NUMBER

--	--	--	--	--

\* 3 7 4 9 2 2 0 5 7 0 \*

**DESIGN AND TECHNOLOGY**

**0445/32**

Paper 3 Resistant Materials

**May/June 2012**

**1 hour**

Candidates answer on the Question Paper.

No Additional Materials are required.

**To be taken together with Paper 1 in one session of 2 hours 15 minutes.**

**READ THESE INSTRUCTIONS FIRST**

Write your Centre number, candidate number and name on all the work you hand in.

Write in blue or black pen.

You may use a soft pencil for any diagrams, graphs or rough working.

Do not use staples, paper clips, highlighters, glue or correction fluid.

DO **NOT** WRITE IN ANY BARCODES.

**Section A**

Answer **all** questions in this section.

**Section B**

Answer **one** question in this section.

You may use a calculator.

The total of the marks for this paper is 50.

The number of marks is given in brackets [ ] at the end of each question or part question.

For Examiner's Use	
<b>Section A</b>	
<b>Section B</b>	
<b>Total</b>	

This document consists of **14** printed pages and **2** blank pages.



**Section A**

Answer **all** questions in this section.

1 Fig. 1 shows a cordless rechargeable drill.

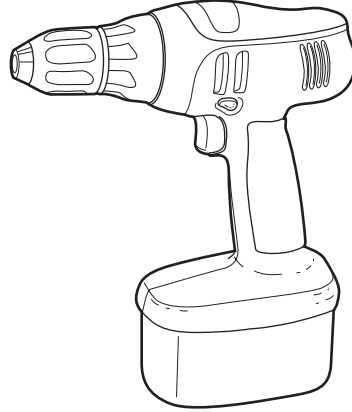

**Fig. 1**

(a) State **one** benefit of using a cordless rechargeable drill.

..... [1]

(b) State **one** drawback of using a cordless rechargeable drill.

..... [1]

2 (a) Name the types of file shown in section below.

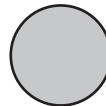

..... [4]

(b) Describe **one** safety check you should carry out before using a file.

..... [1]

3 (a) Name the measuring tool shown in Fig. 2.

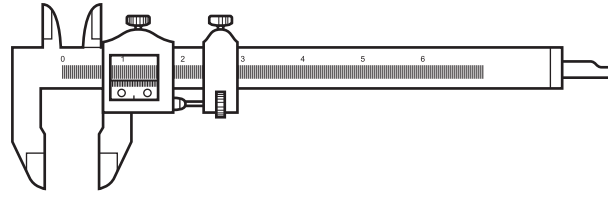

Fig. 2

..... [1]

(b) Give **one** specific use for the tool in Fig. 2.

..... [1]

4 Fig. 3 shows two methods of seasoning timber.

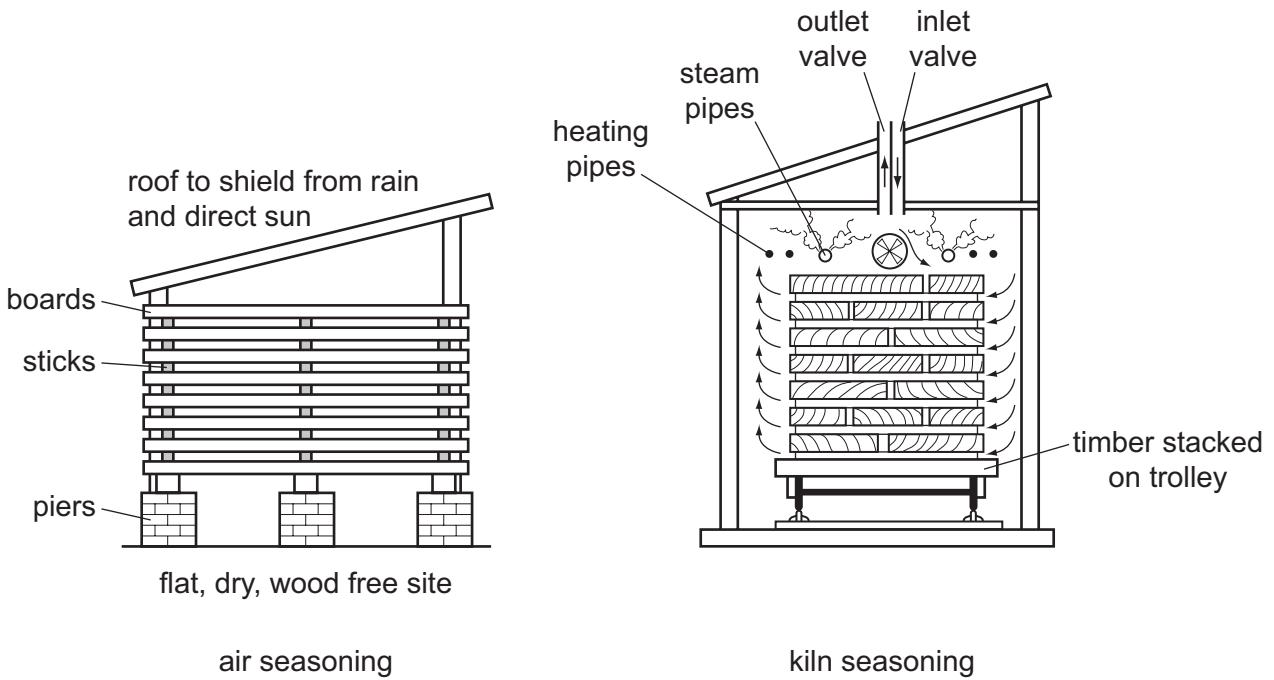

Fig. 3

(a) State **one** advantage of air seasoning.

..... [1]

(b) State **one** advantage of kiln seasoning.

..... [1]

5 Fig. 4 shows two different kettles.

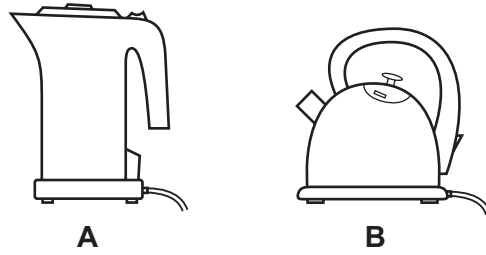

Fig. 4

(a) Name a specific plastic for the body of kettle A.

..... [1]

(b) Name a specific metal for the body of kettle B.

..... [1]

6 Fig. 5 shows a haunched mortise and tenon joint.

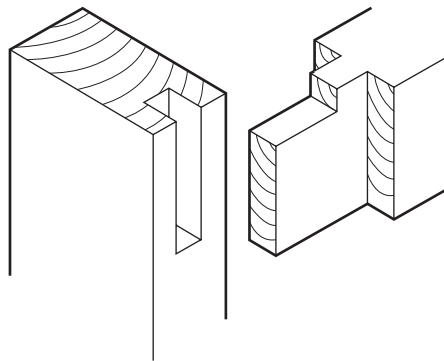

Fig. 5

Label the following parts of the joint on Fig. 5: **mortise tenon shoulder haunch** [4]

7 Planing across the end grain of solid wood can result in the splitting shown in Fig. 6.

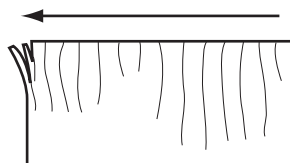

Fig. 6

Describe **two** ways by which this could be prevented.

1 ..... [1]

2 ..... [1]

- 8 Complete the drawing below to show how the odd-leg calipers would be used to mark a line on the metal.

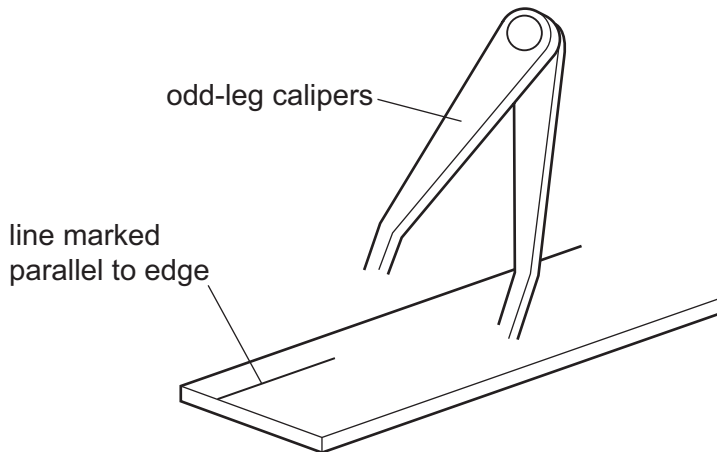

[2]

- 9 Complete the drawing below to show the construction of blockboard.

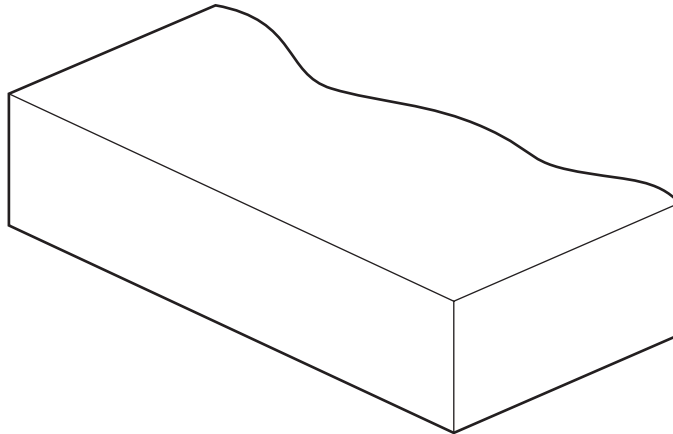

[2]

- 10 The machine screw shown in Fig. 7 is tightened by means of an allen key. Give **two** benefits of using an allen key to tighten the machine screw.

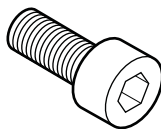

Fig. 7

1 ..... [1]

2 ..... [1]

Section B

Answer **one** question from this section.

11 Fig. 8 shows a tray used by elderly people.

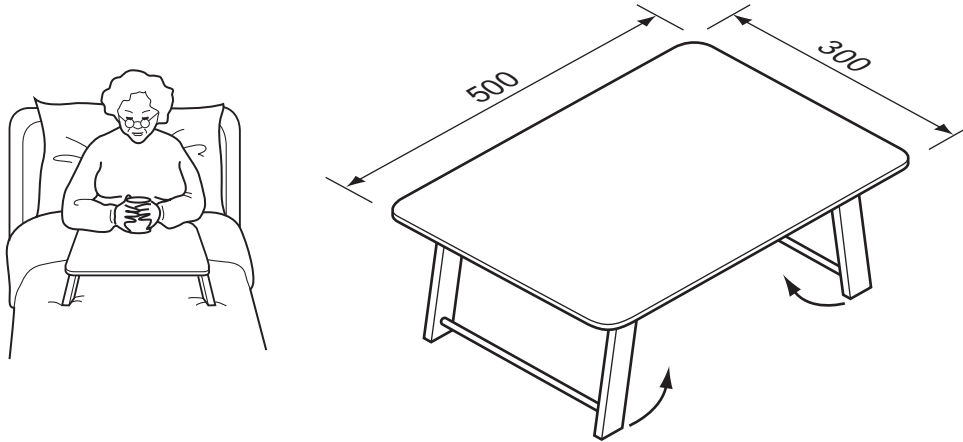

Fig. 8

(a) Explain how the designer has used anthropometric data in the design of the tray.

.....

..... [2]

(b) Fig. 9 shows the underside of the tray. Add sketches and notes to Fig. 9 to show how the legs could be made to fold against the tray top for ease of storage.

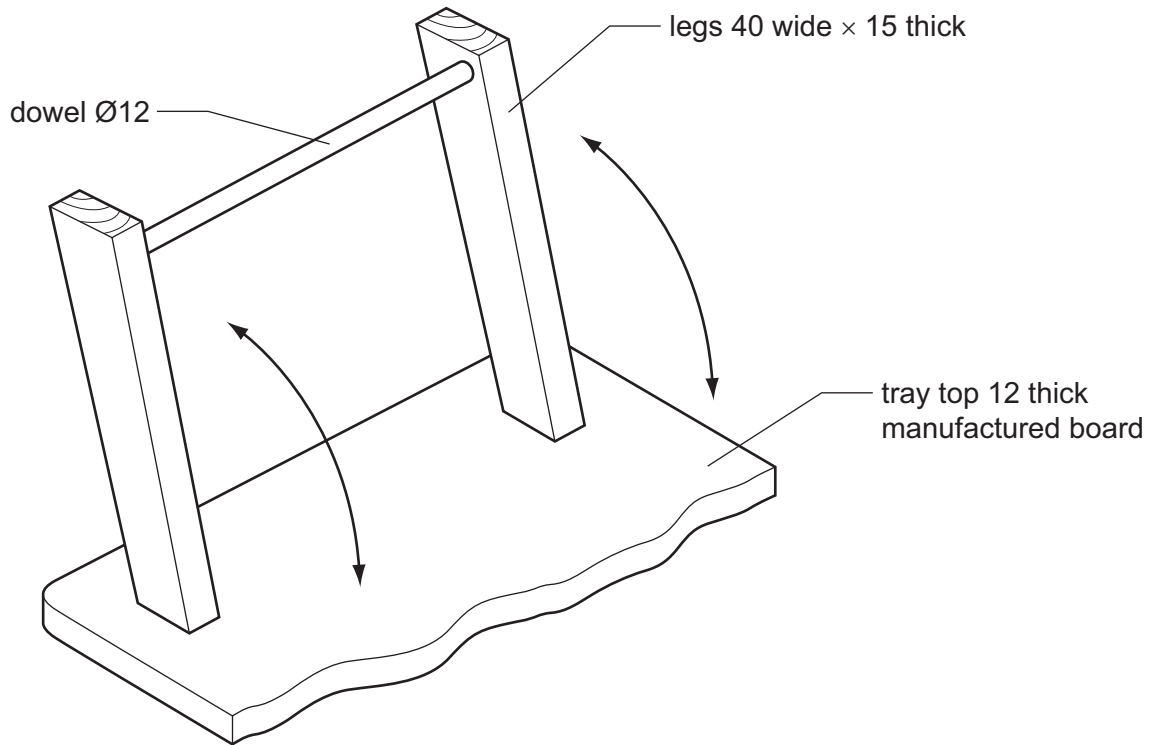

Fig. 9

[5]

- (c) (i) Fig. 10 shows one end of the dowel used to join the legs.  
Add sketches to Fig. 10 to show how the end of the dowel could be prepared to make it easier to be glued into the leg.

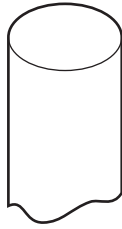

Fig. 10

[2]

- (ii) Fig. 11 shows the legs and dowel glued together. Add sketches to Fig. 11 to show how the legs and dowel could be clamped together while the glue sets.

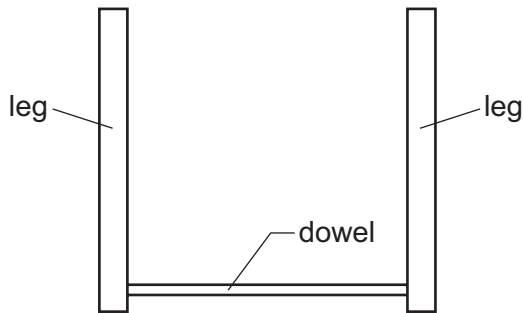

Fig. 11

[3]

- (iii) Name a suitable glue that could be used to join the dowel to the legs and state its drying time.

Glue ..... [1]

Drying time ..... [1]

- (d) Use sketches and notes to show **two** functional improvements to the tray.

[4]

(e) The tray top will be finished with polyurethane varnish.

(i) Give **two** reasons why polyurethane varnish is a suitable finish for the tray top.

1 ..... [1]

2 ..... [1]

(ii) Describe how the surface of the tray top could be prepared before applying the polyurethane varnish.

.....  
.....  
..... [3]

(f) The tray top could be made from plastic. State **two** advantages of using plastic for the tray top rather than a manufactured board.

1 ..... [1]

2 ..... [1]



12 Fig. 12 shows a bracket made from mild steel sheet that could be used to support a variety of garden tools.

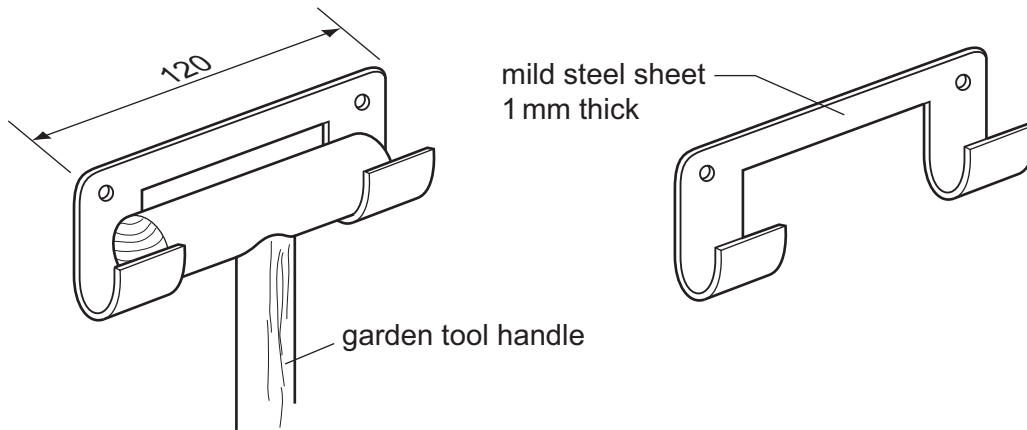

Fig. 12

(a) State **two** properties of mild steel that make it suitable for the bracket.

- 1 ..... [1]
- 2 ..... [1]

(b) State **two** important pieces of information you would need to find out before designing the bracket.

- 1 ..... [1]
- 2 ..... [1]

(c) Fig. 13 shows the steel sheet from which the bracket will be made. Draw the flat shape of the bracket before bending and the positions for the holes on Fig. 13.

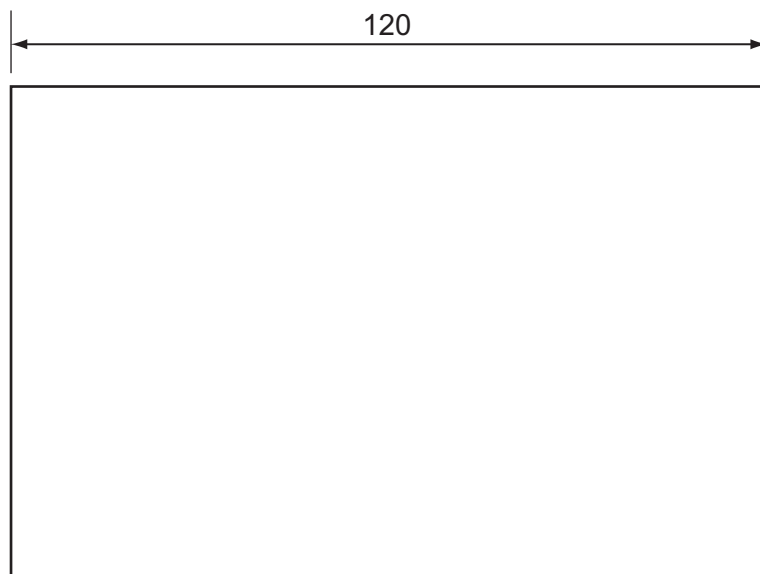

Fig. 13

[2]

(d) (i) Give **one** reason why a centre punch would be used to mark the centre of the holes before they are drilled.

..... [1]

(ii) State **two** safety precautions you would take when drilling sheet steel.

1 ..... [1]

2 ..... [1]

(e) Give **two** reasons why a template would be useful when making twenty brackets.

1 ..... [1]

2 ..... [1]

(f) The bracket will be cut from mild steel sheet and bent to shape.  
Use sketches and notes to show how the following processes could be carried out.  
Name all the tools used.

(i) Cutting the mild steel sheet to shape.

[4]

(ii) Bending the mild steel sheet to shape.

[4]

**(g) (i)** Give **two** reasons why the bracket would be painted.

1 ..... [1]

2 ..... [1]

**(ii)** Describe how the surface of the mild steel sheet would be prepared before it is painted.

.....

.....

..... [2]

**(h)** The bracket will be screwed to the side of a wooden shed.  
Sketch and name the type of screws used.

[2]

13 Fig. 14 shows an incomplete design for a case containing artist's painting equipment.

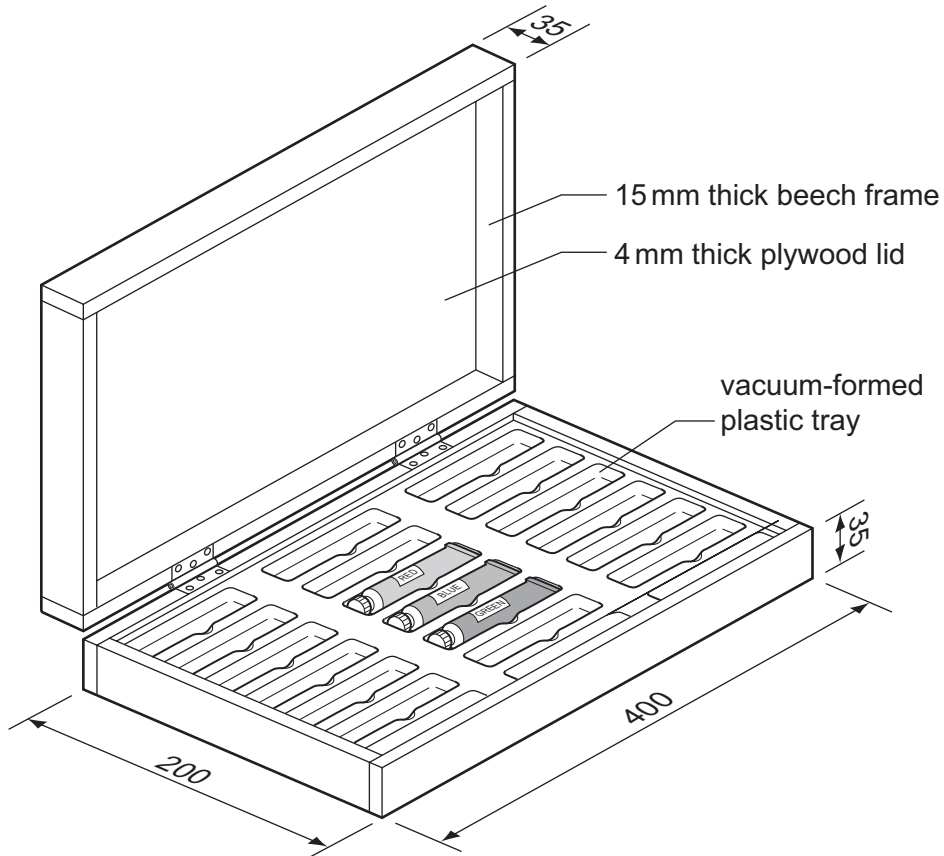

Fig. 14

(a) Explain how the designer has considered ergonomics in the design of the case.

.....

.....

..... [2]

(b) (i) Use sketches and notes to show how the vacuum-formed plastic tray would be supported inside the case.

[3]

(ii) Give **two** advantages of using a vacuum-formed plastic tray to store the tubes of paint rather than separate wooden partitions.

1 ..... [1]

2 ..... [1]

(c) Hinges used to join the two halves of the case will be recessed into the edge of the case. Fig. 15 shows one recess marked out, ready to be cut out.

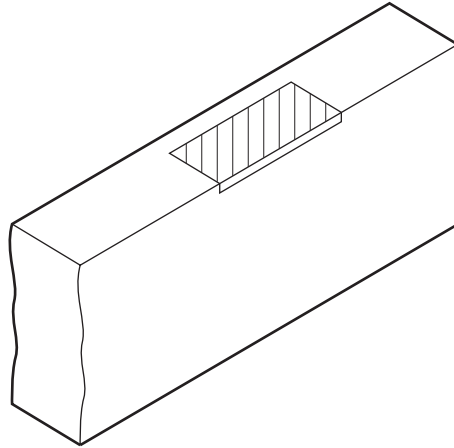

Fig. 15

(i) Name a suitable hinge used to join the two halves of the case.

..... [1]

(ii) Name **two** marking out tools, other than a pencil and steel rule, that could be used to mark out the recess.

1 ..... [1]

2 ..... [1]

(iii) Use sketches and notes to show how the recess could be cut out. Name all the tools used.

[3]

- (d) Use sketches and notes to show how the 4 mm thick plywood lid could be fitted inside the 15 mm thick beech frame. The edges of the plywood must not be visible.

[3]

- (e) Use sketches and notes to show a pre-manufactured fitting that could be used to fasten the two halves of the case securely when being carried.

[3]

- (f) Use sketches and notes to show how artists' paintbrushes could be stored inside the lid. The design must:

- store the paintbrushes securely;
- protect the bristles of the paintbrushes;
- include details of materials and fittings used.

[6]



**BLANK PAGE**

---

Permission to reproduce items where third-party owned material protected by copyright is included has been sought and cleared where possible. Every reasonable effort has been made by the publisher (UCLES) to trace copyright holders, but if any items requiring clearance have unwittingly been included the publisher will be pleased to make amends at the earliest possible opportunity.

University of Cambridge International Examinations is part of the Cambridge Assessment Group. Cambridge Assessment is the brand name of University of Cambridge Local Examinations Syndicate (UCLES), which is itself a department of the University of Cambridge.