



UNIVERSITY OF CAMBRIDGE INTERNATIONAL EXAMINATIONS
International General Certificate of Secondary Education

CANDIDATE
NAME

CENTRE
NUMBER

--	--	--	--	--

CANDIDATE
NUMBER

--	--	--	--

* 8 5 5 0 3 7 8 3 5 7 *

DESIGN AND TECHNOLOGY

0445/33

Paper 3 Resistant Materials

October/November 2012

1 hour

Candidates answer on the Question Paper.

No Additional Materials are required.

To be taken together with Paper 1 in one session of 2 hours 15 minutes.

READ THESE INSTRUCTIONS FIRST

Write your Centre number, candidate number and name on all the work you hand in.

Write in blue or black pen.

You may use a soft pencil for any diagrams, graphs or rough working.

Do not use staples, paper clips, highlighters, glue or correction fluid.

DO **NOT** WRITE IN ANY BARCODES.

Section A

Answer **all** questions in this section.

Section B

Answer **one** question in this section.

You may use a calculator.

The total of the marks for this paper is 50.

The number of marks is given in brackets [] at the end of each question or part question.

For Examiner's Use	
Section A	
Section B	
Total	

This document consists of **15** printed pages and **1** blank page.



Section A

Answer **all** questions in this section.

- 1 Fig. 1 shows a metal bracket screwed to a block of wood.

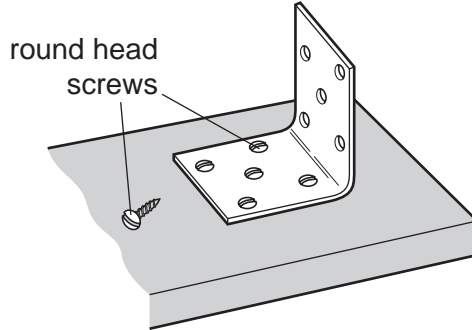

Fig. 1

Give **one** reason why round head screws have been used rather than countersunk head screws.

..... [1]

- 2 Fig. 2 shows a solid wood board that has warped. Give **two** reasons why the solid wood board has warped.

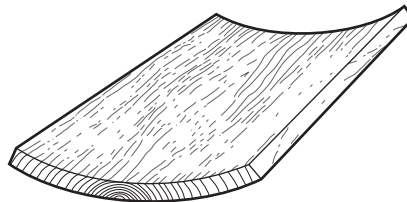
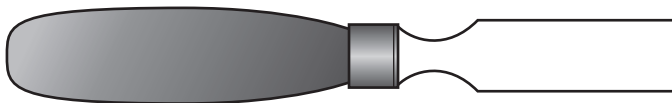

Fig. 2

1 [1]

2 [1]

- 3 Complete the drawing below to show a firmer chisel.



[2]

4 Complete the table below by naming the tool or item of equipment and stating a specific use.

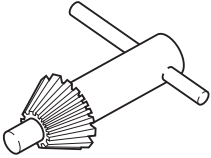
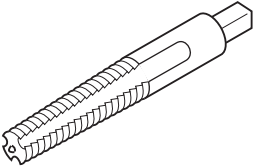
Tool/item of equipment	Name	Specific use
		
		

[4]

5 Name the **two** standard metal sections shown below.

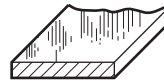
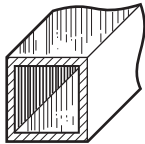

.....

.....

[2]

6 Fig. 3 shows a plastic kettle.



Fig. 3

(a) Name a specific plastic for the kettle.

..... [1]

(b) Name a method of manufacture for the body of the kettle.

..... [1]

(c) Give **two** advantages of using a plastic rather than a metal for the kettle.

1 [1]

2 [1]

7 Complete the drawing below to show a junior hacksaw.

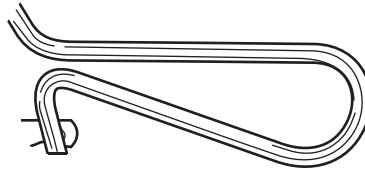

[2]

8 Annealing is carried out when metal becomes work hardened due to hammering. Describe how brass sheet would be annealed.

.....

.....

..... [2]

9 Complete the drawing below to show a flat bit.

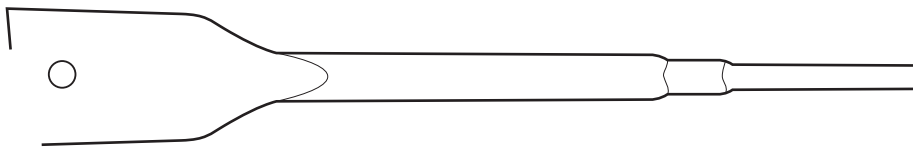

[2]

10 Complete the table below by giving the drying time and a specific use for each adhesive.

Adhesive	Drying time	Specific use
PVA		
Synthetic Resin		

[4]

Section B

Answer **one** question in this section.

- 11 Fig. 4 shows views of a basic design for a computer desk made from 18mm thick manufactured board. The computer desk is sold as flat-pack for self-assembly.

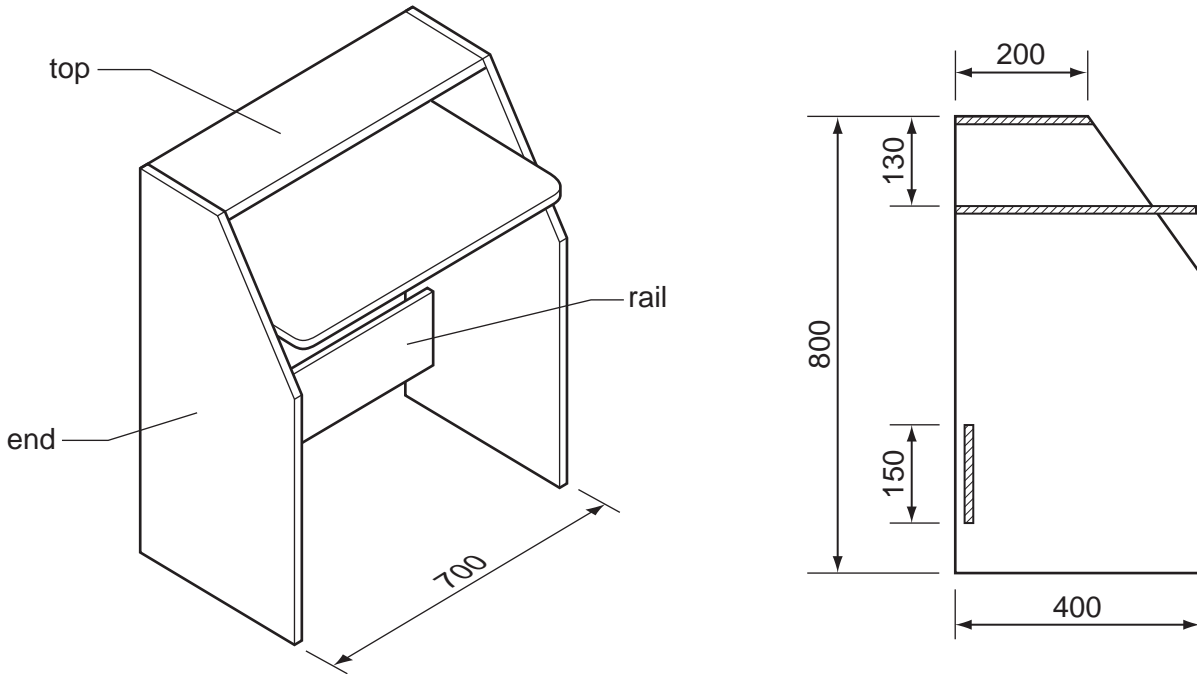

Fig. 4

- (a) Name **two** suitable manufactured boards that could be used for the computer desk.

1 [1]
 2 [1]

- (b) State **two** advantages of using manufactured board rather than solid wood for the computer desk.

1 [1]
 2 [1]

- (c) Give **two** reasons why flat-pack furniture is very popular with consumers.

1 [1]
 2 [1]

(d) Fig. 5 shows two KD (knock-down) fittings used to assemble parts of the computer desk.

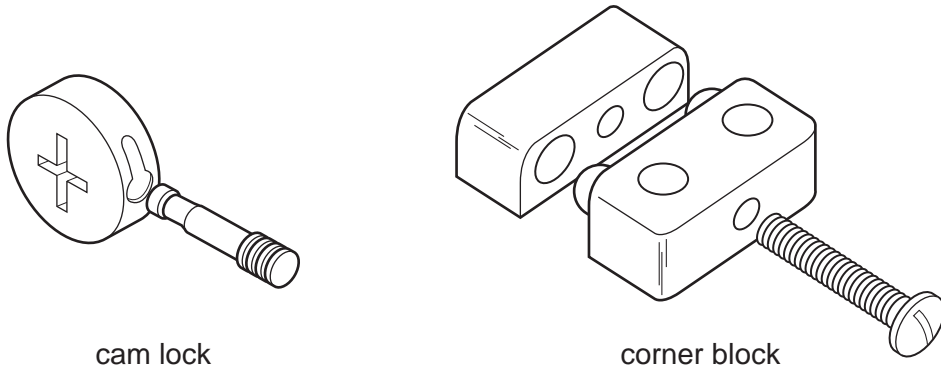

Fig. 5

(i) Use sketches and notes to show how the cam lock could be used to join the top to one end of the computer desk.

[3]

(ii) Use sketches and notes to show how the corner block could be used to join the rail to one end of the computer desk.

[3]

- (e) Fig. 6 shows one end of the computer desk marked out, ready to be cut to shape.

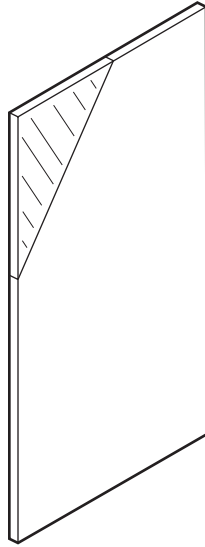

Fig. 6

- (i) Name a portable power saw that could be used to saw off the waste wood.
 [1]
- (ii) State **one** safety precaution you would take when using the saw named in (i).
 [1]
- (iii) Use sketches and notes to show how the sawn edge would be planed flat.
 Name the type of plane used and the method of holding the manufactured board.

[3]

(f) Fig. 7 shows a computer tower and a CD case.

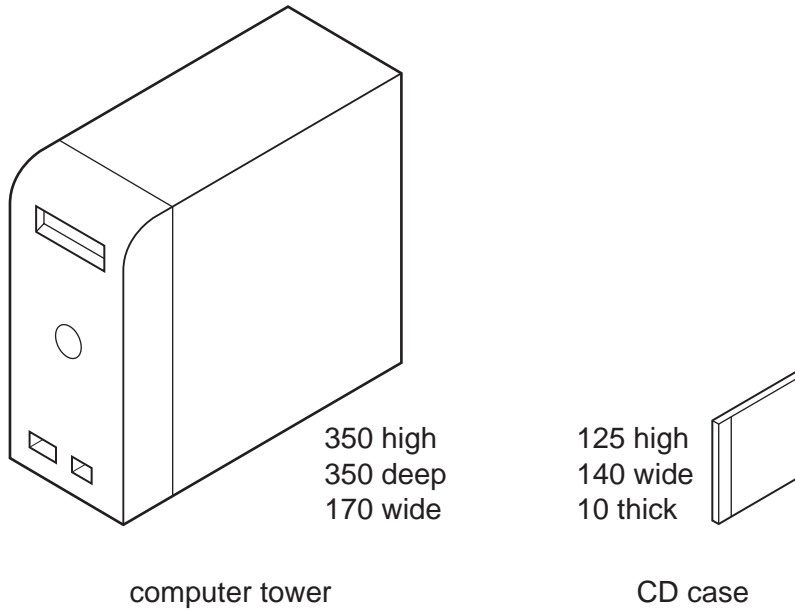

Fig. 7

The basic design of the computer desk needs to be modified.
Use sketches and notes to show modifications to the computer desk so that it can store the computer tower and 20 CDs.
Include details of materials, constructions and fittings used.

- 12 Fig. 8 shows a signboard that could be attached to an office door. The coloured acrylic slider moves across to show either 'IN' or 'OUT'.

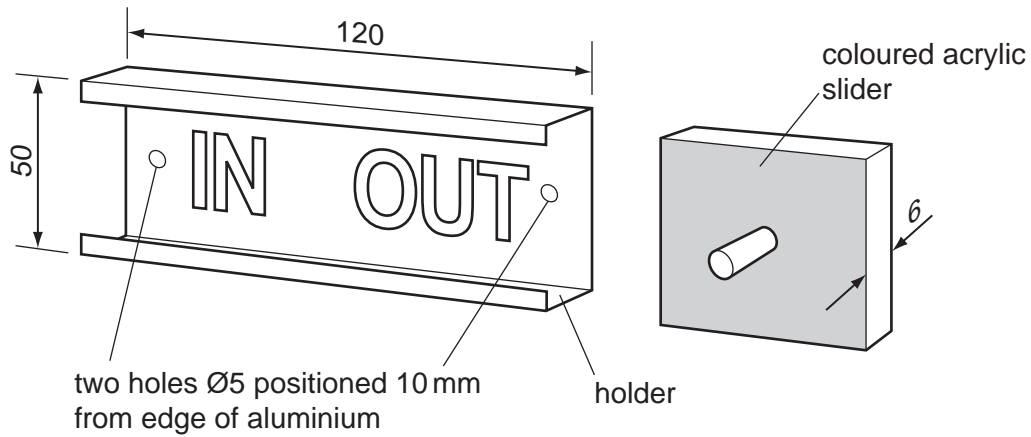

Fig. 8

- (a) Give **two** advantages of using aluminium rather than steel for the holder.

1 [1]

2 [1]

- (b) Fig. 9 shows the aluminium blank from which the holder will be made.

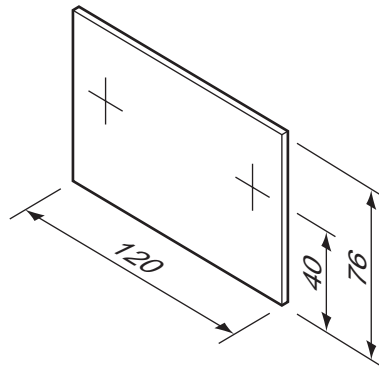

Fig. 9

Complete the table below by naming **one** tool used for each process.

Stage	Process	Tool
1	Mark out blank on sheet of aluminium	
2	Cut out blank	
3	Make edges flat	
4	Mark out centres for holes	
5	Drill holes	
6	Clean surface of blank	

[6]

10

(c) Fig. 10 shows a pre-drilled aluminium blank ready to be bent to shape for the holder.

For
Examiner's
Use

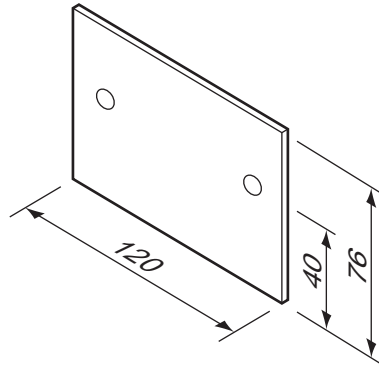

Fig. 10

Use sketches and notes to show a design for a bending jig that could be used to produce ten identical holders. The jig must use both 5 mm diameter holes to locate the blanks. Describe clearly how the jig would be used.

[6]

- (d) Use sketches and notes to show a modification to the signboard that will stop the slider falling out of the holder during use.

[2]

- (e) Describe the stages involved in making the slider. Include details to explain how the acrylic rod would be fixed to the slider.

.....

.....

.....

.....

..... [4]

- (f) The holder for the signboard could also be made from MDF or acrylic sheet. Use sketches and notes to show how the holder for the sign board could be made from **either** MDF **or** acrylic sheet.

[5]

13 Fig. 11 shows a rack used to support garden tools. The rack is made from 19 mm thick softwood.

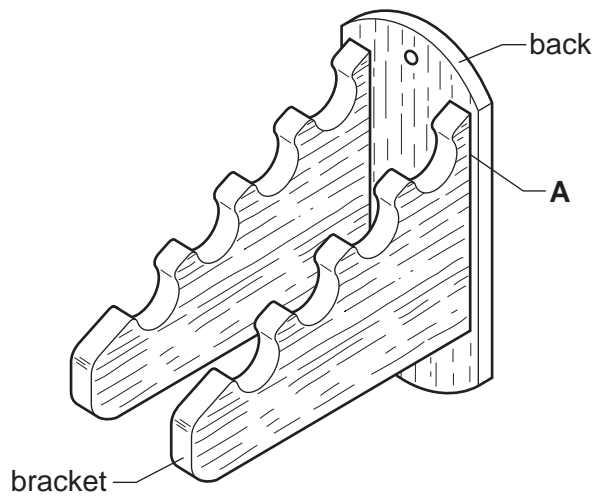

Fig. 11

(a) State **three** items of research the designer would need to carry out when designing the rack for garden tools.

1 [1]

2 [1]

3 [1]

(b) (i) Use sketches and notes to show a suitable construction used to join the bracket permanently to the back of the rack at **A**.

[3]

(ii) Name the joint you have drawn.

..... [1]

(c) Fig. 12 shows one side of the bracket marked out ready to be cut out and shaped.

For
Examiner's
Use

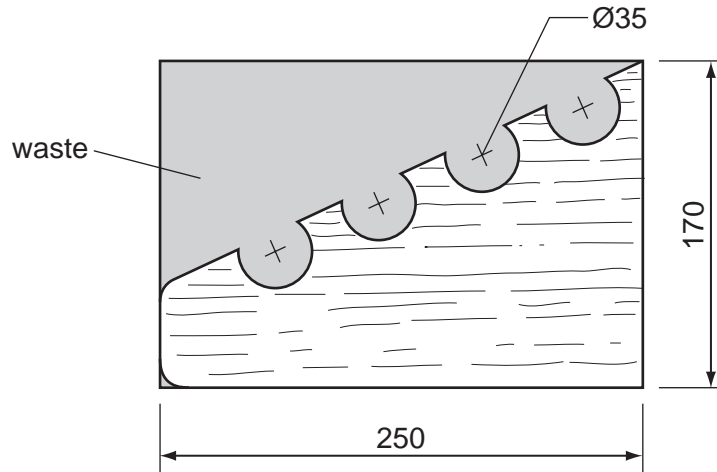

Fig. 12

Use sketches and notes to show how the side of the bracket could be produced.

[6]

(d) Fig. 13 shows one side of the bracket cut out.

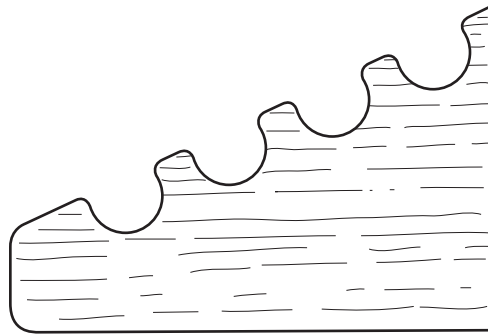

Fig. 13

(i) Indicate clearly on Fig. 13 **one** example of 'short grain'. [1]

(ii) Explain why short grain is a problem that occurs only in solid wood and not in manufactured boards.

.....
..... [2]

(e) (i) Give **two** reasons why the rack would need to have an applied finish. [1]

1 [1]

2 [1]

(ii) Name **two** suitable finishes, other than paint, for the rack. [1]

1 [1]

2 [1]

(iii) Describe how the surface would be prepared to take **one** of the finishes named in (ii).

Chosen finish
.....
.....
..... [3]

- (iv) A finish could be applied before or after the parts of the rack are assembled. State **one** advantage of applying a finish before the parts are assembled and **one** advantage of applying a finish after the parts are assembled.

Advantage of applying a finish **before** the parts are assembled

..... [1]

Advantage of applying a finish **after** the parts are assembled

..... [1]

BLANK PAGE

Permission to reproduce items where third-party owned material protected by copyright is included has been sought and cleared where possible. Every reasonable effort has been made by the publisher (UCLES) to trace copyright holders, but if any items requiring clearance have unwittingly been included the publisher will be pleased to make amends at the earliest possible opportunity.

University of Cambridge International Examinations is part of the Cambridge Assessment Group. Cambridge Assessment is the brand name of University of Cambridge Local Examinations Syndicate (UCLES), which is itself a department of the University of Cambridge.