



UNIVERSITY OF CAMBRIDGE INTERNATIONAL EXAMINATIONS
International General Certificate of Secondary Education

CANDIDATE
NAME

CENTRE
NUMBER

--	--	--	--	--

CANDIDATE
NUMBER

--	--	--	--	--

* 9 1 7 2 7 2 7 2 7 3 8 9 *

DESIGN AND TECHNOLOGY

0445/33

Paper 3 Resistant Materials

October/November 2013

1 hour

Candidates answer on the Question Paper.

No Additional Materials are required.

To be taken together with Paper 1 in one session of 2 hours 15 minutes.

READ THESE INSTRUCTIONS FIRST

Write your Centre number, candidate number and name on all the work you hand in.

Write in blue or black pen.

You may use a soft pencil for any diagrams, graphs or rough working.

Do not use staples, paper clips, highlighters, glue or correction fluid.

DO NOT WRITE IN ANY BARCODES.

Section A

Answer **all** questions in this section.

Section B

Answer **one** question in this section.

You may use a calculator.

The total of the marks for this paper is 50.

The number of marks is given in brackets [] at the end of each question or part question.

For Examiner's Use	
Section A	
Section B	
Total	

This document consists of **14** printed pages and **2** blank pages.



Section A

Answer **all** questions in this section.

1 Give **two** properties of balsa wood that make it suitable for model making.

- 1
- 2 [2]

2

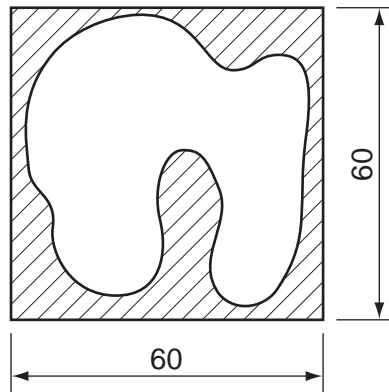

Name the type of saw used to cut the curved shape shown above when the sheet material is:

(a) 4 mm thick MDF;

..... [1]

(b) 1 mm thick brass.

..... [1]

3 State the tool used to tighten each of the fastenings shown below.

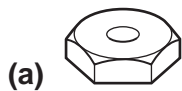

..... [1]

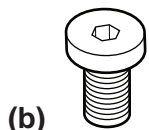

..... [1]

4 Fig. 1 shows a drinks can.

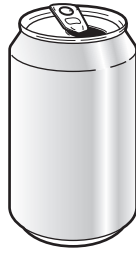

Fig. 1

(a) Name the non-ferrous metal used to make the drinks can shown in Fig. 1.

..... [1]

(b) Give **one** reason for using a non-ferrous metal for the drinks can.

..... [1]

5 Describe **two** drawbacks of working with chipboard when making furniture.

1

2 [2]

6 Fig. 2 shows two watering cans made from different materials.

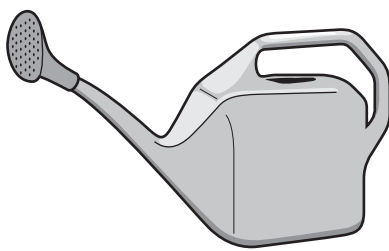

plastic

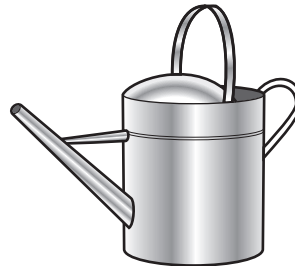

metal

Fig. 2

Give **two** advantages of using a plastic watering can rather than a metal watering can.

1

2 [2]

7 Complete the sketch below to show an **exploded** view of a through housing joint.

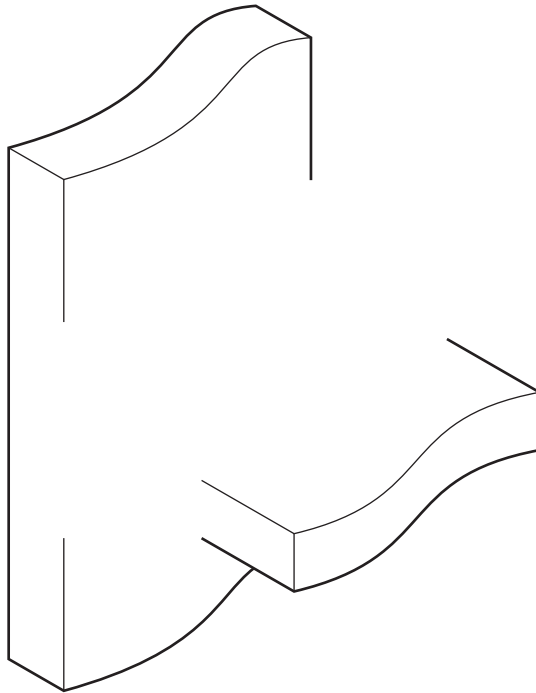

[3]

8 Fig. 3 shows part of three solid wood boards joined together to make a table top.

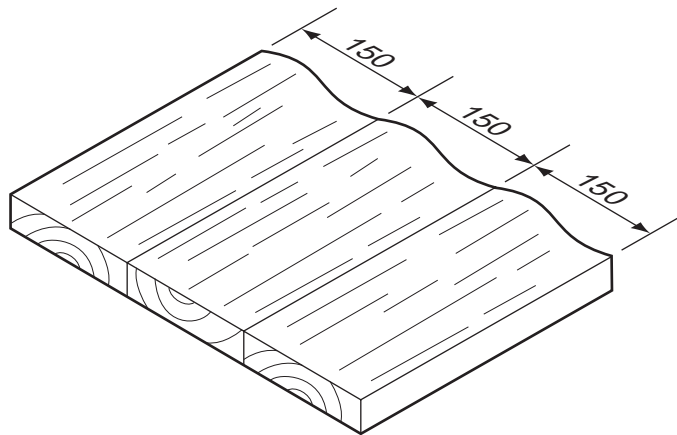

Fig. 3

Give **two** reasons why the table top has been constructed as shown in Fig. 3.

1

2 [2]

9 Complete the table below by naming each tool and giving a specific use.

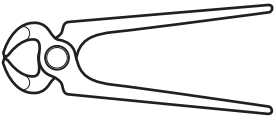
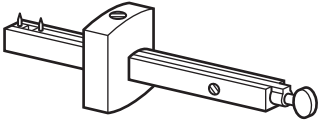
Tool	Name	Specific use
		
		

[4]

10 Fig. 4 shows four products made from plastic.



washing-up liquid bottle



boat hull

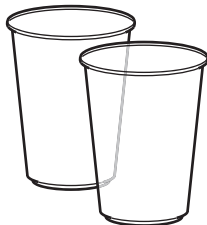

disposable cups



comb

Fig. 4

Name a specific plastic that could be used to make each of the products.

washing-up liquid bottle

boat hull

disposable cups

comb..... [4]

Section B

Answer **one** question in this section.

- 11 Fig. 5 shows an incomplete design for a holder that will allow students to carry four paint bottles.

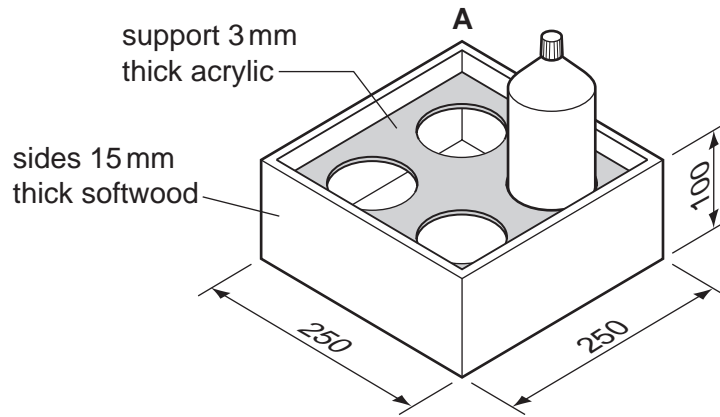

Fig. 5

- (a) Fig. 6 shows a finger (comb) joint used at corner A.

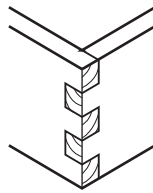

Fig. 6

Use sketches and notes to show how the finger (comb) joint could be marked out and cut out, ready to be fitted together. Include names of all the tools used.

(b) Use sketches and notes to show how the four sides of the holder could be glued and held together.

Include:

- the name of a suitable adhesive;
- the method of holding the sides together.

[5]

(c) Fig. 7 shows the acrylic support with the holes marked out ready to be cut out.

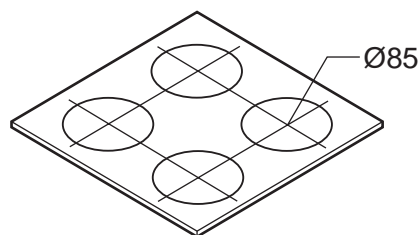

Fig. 7

(i) Use sketches and notes to show how **one** hole could be cut out and the edges made smooth.

[4]

(ii) Give **one** safety precaution you would take when working with acrylic.

..... [1]

- (d)** Use sketches and notes to show how the 3 mm thick acrylic could be supported inside the holder.

[3]

- (e)** Use sketches and notes to show a modification to the holder so that students could carry the four paint bottles safely.
Include details of materials, constructions and fittings used.

[6]

12 Fig. 8 shows an incomplete design for a holder to support a roll of wire. The stand and the arm are made from mild steel.

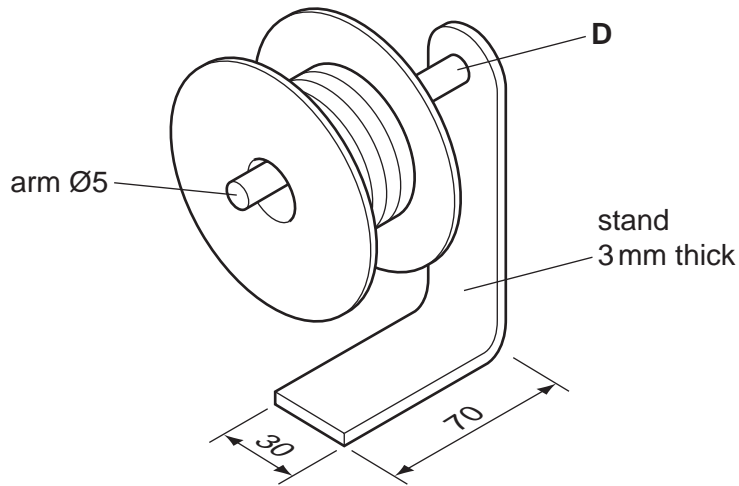

Fig. 8

(a) Give **two** reasons why mild steel is a suitable material for the holder.

- 1
- 2 [2]

(b) Fig. 9 shows the stand of the holder marked out before it is bent to shape.

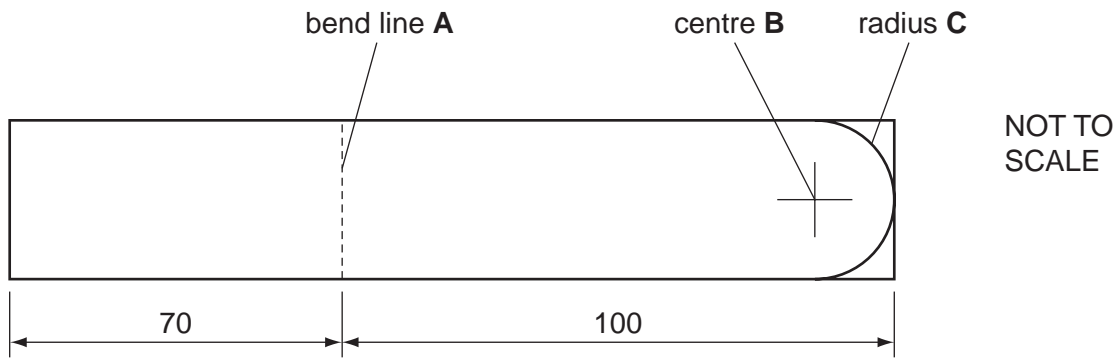

Fig. 9

Name the tools used to mark out:

- bend line **A**
- centre **B**
- radius **C** [3]

(c) Use sketches and notes to show how the mild steel stand could be bent to shape.

*For
Examiner's
Use*

[3]

(d) Use sketches and notes to show how the arm could be joined to the stand at **D** by means of brazing. Name all equipment used and give details describing how the metal would be prepared.

[6]

- (e) Use sketches and notes to show how the arm could be joined to the stand at **D** by means of screw threads. Name all equipment used to cut the screw threads.

[6]

- (f) Use sketches and notes to show how a roll of wire could be prevented from sliding off the arm.

[2]

- (g) Use sketches and notes to show how the design of the holder could be modified to prevent it from falling over. Additional materials may be used.

[3]

- 13 Fig. 10 shows views of an incomplete design for a DVD holder. The body of the DVD holder is made by laminating three layers of 2 mm thick plywood.

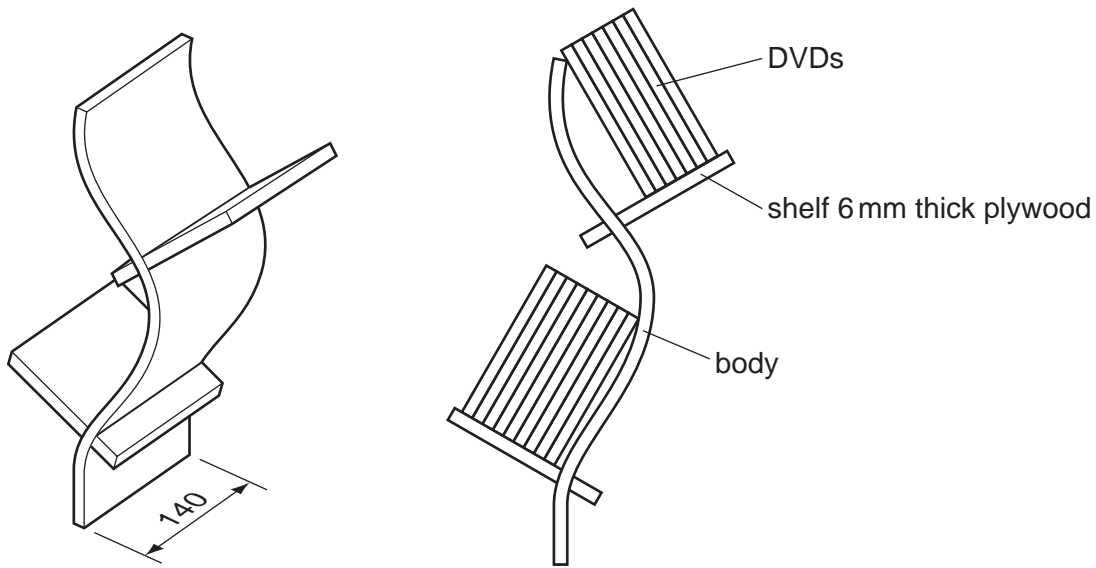

Fig. 10

- (a) Give **two** properties of plywood that make it suitable for the DVD holder.

1

2 [2]

- (b) Give **two** reasons why it could be helpful to make a model of the DVD holder before making it from plywood.

1

2 [2]

- (c) Use sketches and notes to show how the body of the DVD holder could be made by laminating three layers of 2 mm thick plywood.

(d) (i) The shelf is made from 6 mm thick plywood.
Use sketches and notes to show how **one** shelf could be joined to the body of the DVD holder.

[3]

(ii) Name a suitable adhesive that could be used for the joint in **(d)(i)**.

..... [1]

(e) (i) Describe how the surfaces of the body could be prepared to take an applied finish.

.....
.....
.....
..... [3]

(ii) Name a suitable finish for the DVD holder and give a reason for your choice.

Finish

Reason for choice [2]

- (f) Use sketches and notes to design a stable base for the DVD holder.
Include:
- names of materials used;
 - methods of construction;
 - **two** important sizes.

*For
Examiner's
Use*

[6]

BLANK PAGE

Permission to reproduce items where third-party owned material protected by copyright is included has been sought and cleared where possible. Every reasonable effort has been made by the publisher (UCLES) to trace copyright holders, but if any items requiring clearance have unwittingly been included the publisher will be pleased to make amends at the earliest possible opportunity.

University of Cambridge International Examinations is part of the Cambridge Assessment Group. Cambridge Assessment is the brand name of University of Cambridge Local Examinations Syndicate (UCLES), which is itself a department of the University of Cambridge.