



UNIVERSITY OF CAMBRIDGE INTERNATIONAL EXAMINATIONS
International General Certificate of Secondary Education

CANDIDATE
NAME

CENTRE
NUMBER

--	--	--	--	--

CANDIDATE
NUMBER

--	--	--	--



DESIGN AND TECHNOLOGY

0445/41

Paper 4 Systems and Control

October/November 2013

1 hour

Candidates answer on the Question Paper.

No Additional Materials are required.

To be taken together with Paper 1 in one session of 2 hours and 15 minutes.

READ THESE INSTRUCTIONS FIRST

Write your Centre number, candidate number and name on all the work you hand in.

Write in dark blue or black pen.

You may use a soft pencil for any diagrams, graphs or rough working.

Do not use staples, paper clips, highlighters, glue or correction fluid.

DO **NOT** WRITE IN ANY BARCODES.

You may use a calculator.

Section A

Answer **all** questions.

Section B

Answer **one** question.

The total of the marks for this paper is 50.

The number of marks is given in brackets [] at the end of each question or part question.

For Examiner's Use	
Section A	
Section B	
Total	

This document consists of an **18** printed pages and **2** blank pages.



Section A

Answer **all** questions in this section.

1 Fig. 1 shows the support frame for a shelf unit attached to a wall using screws.

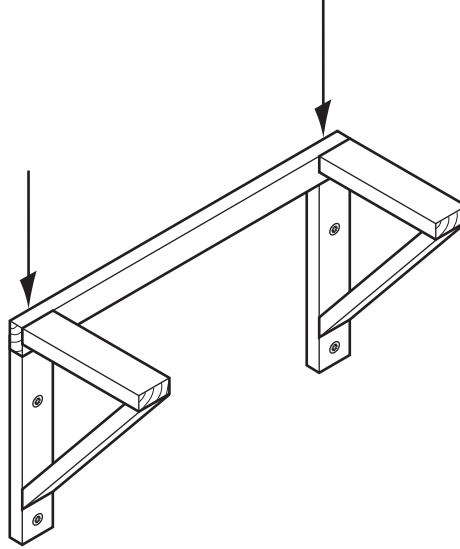

Fig. 1

(a) State the force that was acting on each screw as it was inserted with a screwdriver.

..... [1]

(b) State the force that will act on the screws when a load is applied in the direction of the arrows.

..... [1]

(c) Describe how the factor of safety on the fixing of the support frame to the wall could be increased.

.....
.....
..... [2]

2 Give **one** example of a natural shell structure and **one** example of a manufactured shell structure.

Natural shell structure [1]

Manufactured shell structure [1]

- 3 Draw and name an example of a third-order lever.

[2]

- 4 Use notes and sketches to show how the piece of card in Fig. 2 can be modified to be self-supporting and allow the card to support a compressive load. No additional materials should be used.

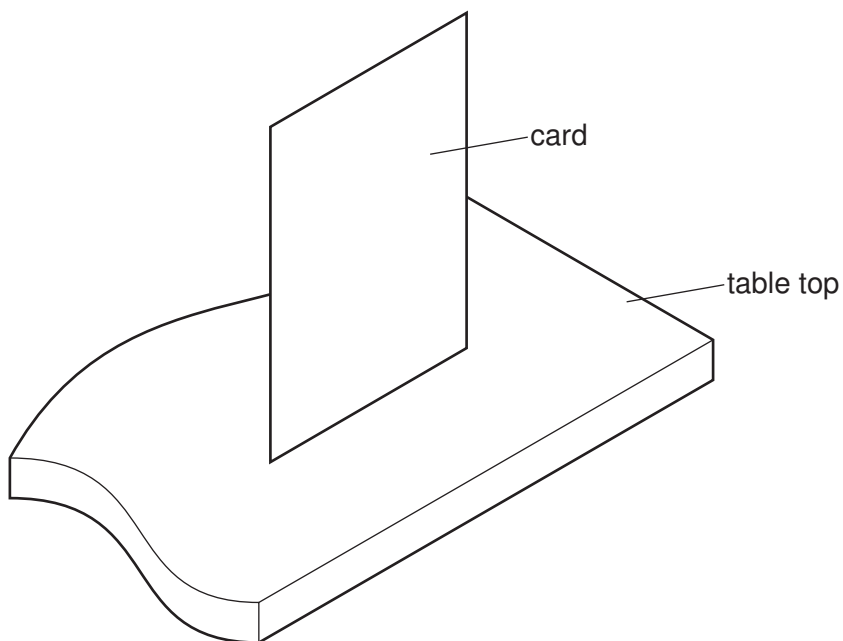

Fig. 2

[2]

5 Fig. 3 shows shear legs being used to raise a load. Add labels to show:

- a structural component in tension;
- a structural component in compression.

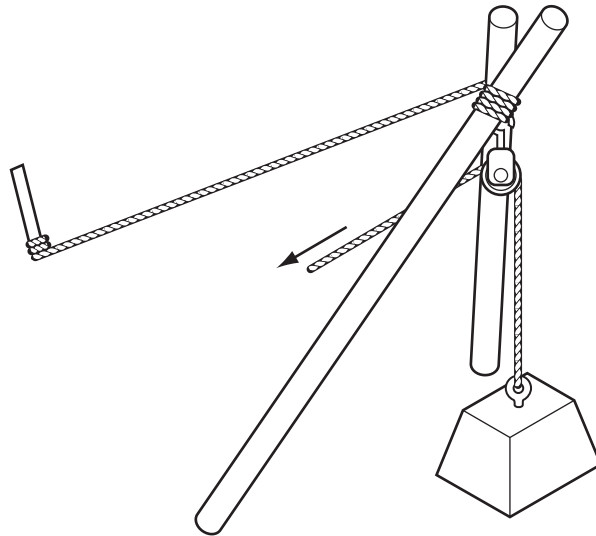

Fig. 3

[2]

6 Fig. 4 shows a gear system.

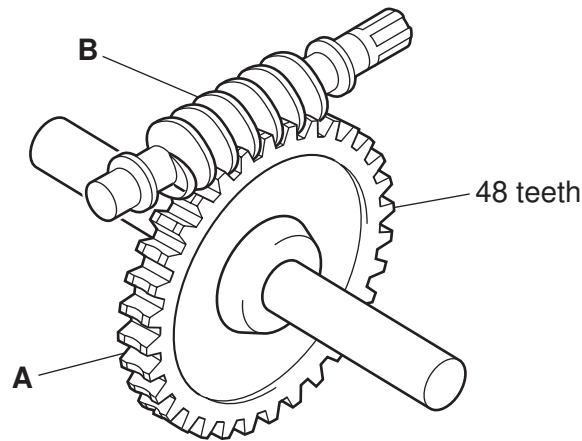

Fig. 4

(a) Name the **two** components in the gear system.

A

B [2]

(b) State the reduction ratio of the gear system in Fig. 4.

..... [1]

7 Complete the following sentence.

(a) A crankshaft converts motion to motion. [2]

(b) Give **one** example of a different mechanism that will produce a similar conversion of motion to a crankshaft.

..... [1]

8 (a) Give **one** reason why colour codes are used on electronic components rather than printed values.

..... [1]

(b) Fig. 5 shows a 560 kΩ, 5% tolerance resistor and a colour code chart.

1st Colour band 1st digit		2nd Colour band 2nd digit		3rd Colour band Number of zeros		4th Colour band Tolerance %	
Black	0	Black	0	Black	0		
Brown	1	Brown	1	Brown	1	Brown	1
Red	2	Red	2	Red	2	Red	2
Orange	3	Orange	3	Orange	3		
Yellow	4	Yellow	4	Yellow	4		
Green	5	Green	5	Green	5		
Blue	6	Blue	6	Blue	6		
Violet	7	Violet	7	Violet	7		
Grey	8	Grey	8	Grey	0.01	Silver	10
White	9	White	9	White	0.1	Gold	5

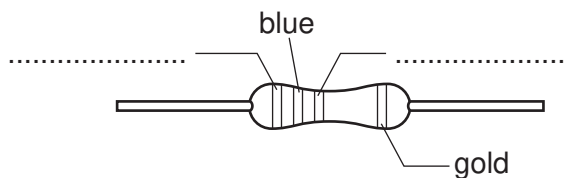

Fig. 5

Complete the diagram of the resistor by adding the missing colours. [2]

- 9 Fig. 6 shows a microswitch and the symbol for the microswitch.

Add connecting wires to the switch to allow it to be used as a push to break switch.

*For
Examiner's
Use*

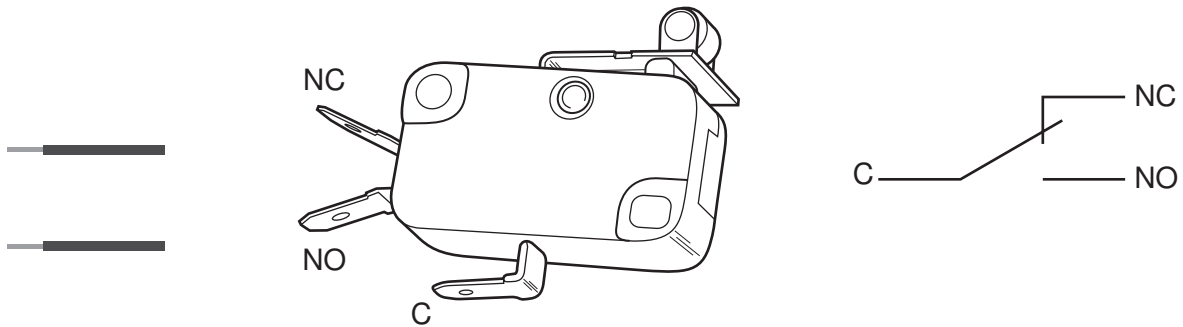

Fig. 6

[2]

- 10 Capacitors used in project work are available in the following values.

0.1 μF 100 pF 470 nF 100 nF 470 pF 1000 μF

Circle the **two** capacitor values that are the same.

[2]

Section B

Answer **one** question from this section.

11 An arched bridge is shown in Fig. 7.

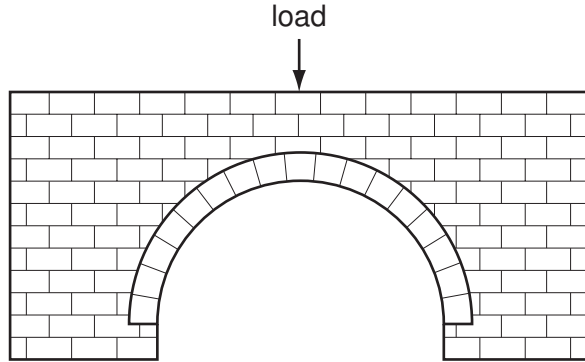

Fig. 7

(a) Use arrows to show the direction of the force through the structure when a load is centrally placed. [2]

(b) Fig. 8 shows a test specimen with one end fixed in position and a load applied at the other end in the direction of the arrow.

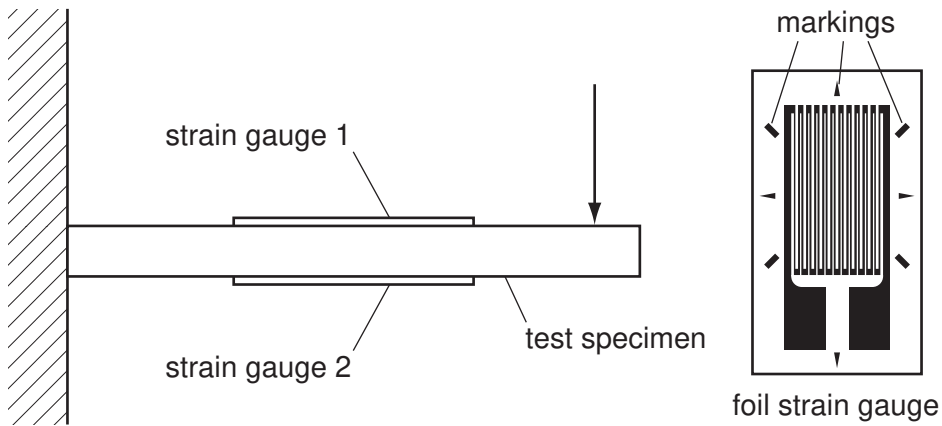

Fig. 8

(i) Describe the changes that the two strain gauges will measure.

.....

 [2]

(ii) Give **one** reason for the markings commonly found on strain gauges.

..... [1]

(c) A stress/strain graph for a sample of mild steel is shown in Fig. 9.

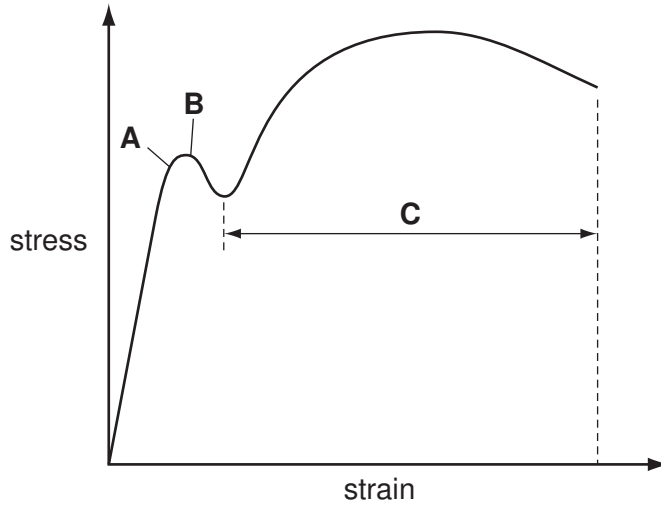

Fig. 9

(i) State what is happening at points **A** and **B** on the graph.

.....
 [2]

(ii) Describe the section of graph indicated by dimension **C**.

..... [1]

(iii) Indicate the area on the graph where Young's modulus will apply.

[2]

(d) A gate made from round steel tube is shown in Fig. 10.
 The frame of the gate is found to be distorting after some use.

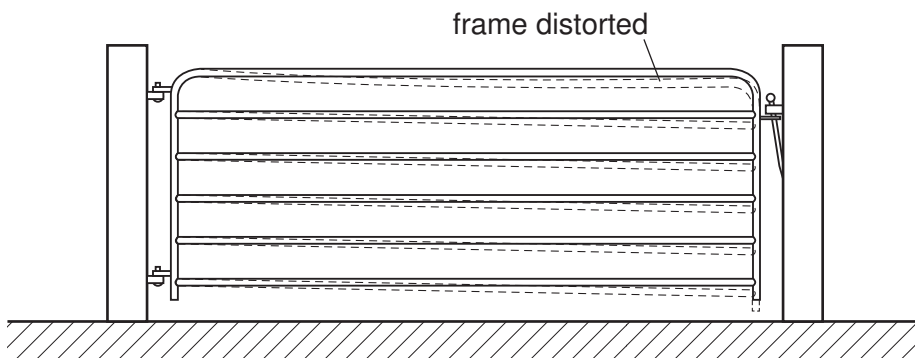

Fig. 10

(i) Add strengthening to the structure in Fig. 10 to overcome the problem.

[2]

(ii) Indicate on the diagram how the strengthening will be fixed to the gate.

[1]

- (e) Fig. 11 shows a framework fixed to a wall. Two forces are shown acting at a point on the frame.

*For
Examiner's
Use*

Find the resultant force at this point.

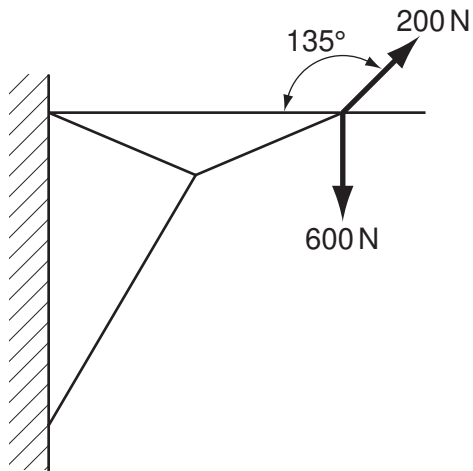

Fig. 11

[3]

- (f) When constructing a beam, two pieces of timber may need to be joined end-to-end in line with each other as shown in Fig. 12.

Use notes and sketches to show a suitable joining method.

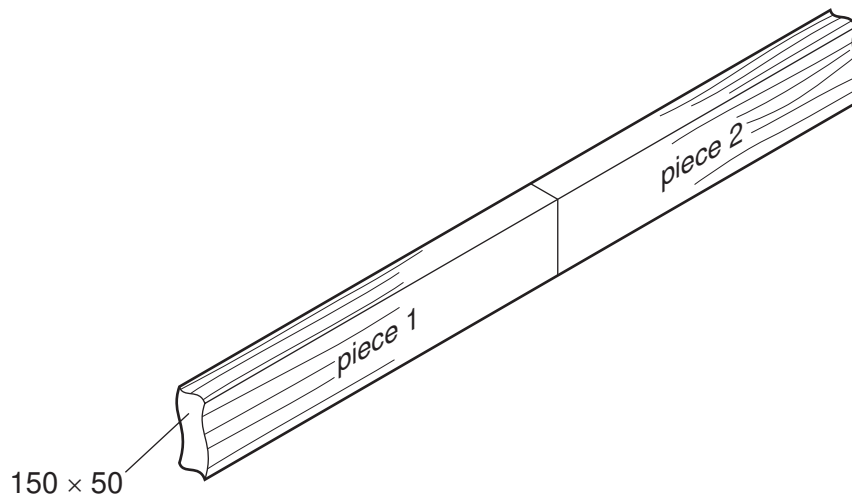

Fig. 12

[4]

(g) (i) State what is meant by a moment in structural terms.

..... [1]

(ii) Fig. 13 shows a wooden beam that is loaded at two points. The beam is supported at points **A** and **B**.

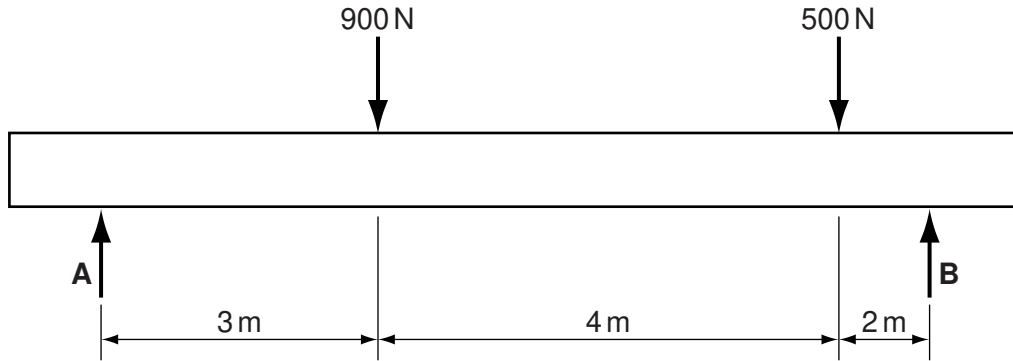

Fig. 13

Calculate the reactions at points **A** and **B** on the beam.

.....

 [4]

12 (a) Fig. 14 shows details of a system for turning an output shaft in a mechanism.

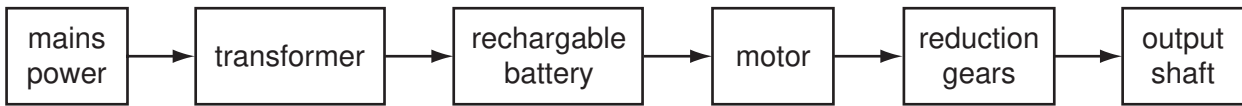

Fig. 14

Give **three** examples of where energy losses occur in the system.

- 1
- 2
- 3 [3]

(b) The system could be operated directly from the transformer, without using a battery.

Give **one** benefit and **one** drawback of using battery power for mechanical systems.

benefit [1]

drawback [1]

(c) A gear system is shown in Fig. 15.

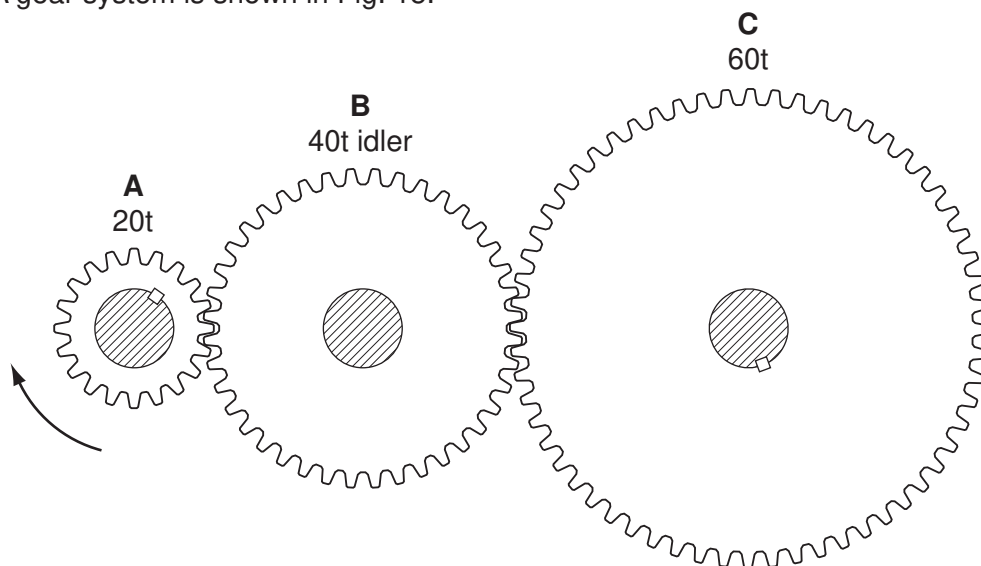

Fig. 15

(i) Add arrows to Fig. 15 to show the direction of rotation of gears **B** and **C**. [2]

(ii) Gear **A** rotates at 60 rpm.

State the speed of rotation of gear **C**.

..... [1]

(iii) Gears **A** and **C** are fixed to their shafts with a key.

Explain why gear **B** does not need to be fixed to the shaft.

.....

.....

..... [2]

(d) Views of a screw jack are shown in Fig. 16.

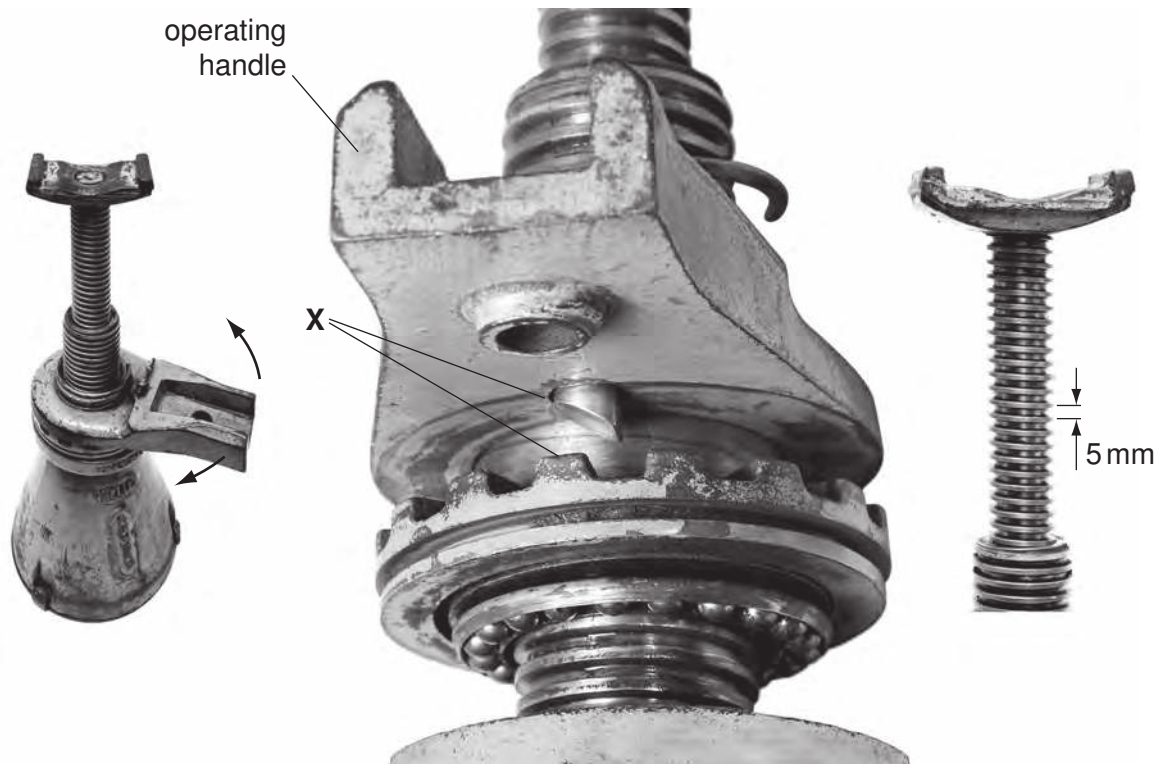

Fig. 16

(i) Circle the term below which describes mechanism **X** which allows the handle to be rotated part way and then pulled back for the next rotation.

rack and pinion cam and follower ratchet and pawl eccentric cam

[1]

(ii) Calculate the number of complete turns of the operating handle required to raise the jack from the closed height of 180 mm to fully open at 350 mm.

.....

.....

..... [2]

(iii) Give **two** ways of reducing the effort needed to raise a screw jack of this type.

1

.....

2

..... [2]

(e) Three different bearing types are shown in Fig. 17.

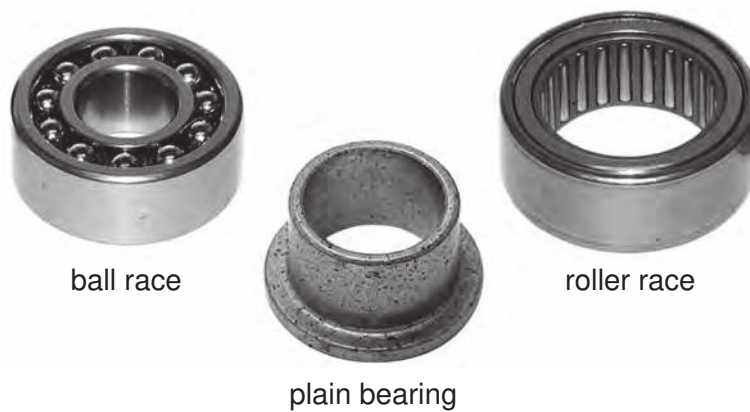

Fig. 17

(i) Give **one** benefit of each type of bearing.

Benefit of ball race

..... [1]

Benefit of roller race

..... [1]

Benefit of plain bearing

..... [1]

(ii) State **one** benefit of making the plain bearing from nylon.

.....

..... [1]

- (iii) Explain why a nylon bearing is only suitable for supporting an axle rotating at low speed.

.....

 [2]

- (f) Fig. 18 shows a railway signal and the bell crank lever used to operate it.

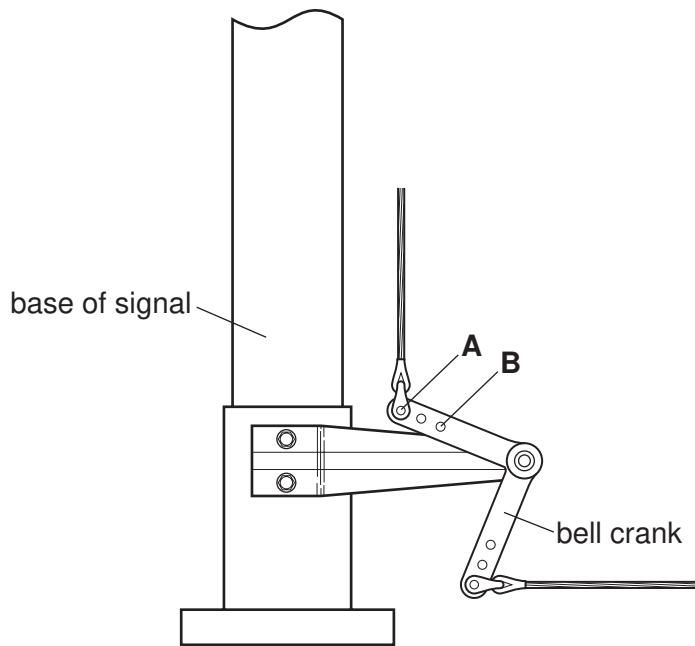

Fig. 18

- (i) Describe the function of a bell crank lever.

.....
 [2]

- (ii) Give **two** effects of moving the output linkage from position **A** to position **B**.

1

.....

2

..... [2]

13 (a) Materials used for connecting electronic components must be good electrical conductors.

(i) From the list below, select **three** materials that are good electrical conductors.

- | | | | |
|-------------|--------|-----|---------|
| polystyrene | silver | PVC | ceramic |
| MDF | brass | tin | glass |

1 2 3 [3]

(ii) Semiconductor materials such as germanium and silicon are used in some electronic components.

Give the name of **one** electronic component that contains a semiconductor.

..... [1]

(iii) Fig. 19 shows views of a calculator in which a sheet of conductive rubber is used for the keypad switches, making an electrical connection between two points on the gold-plated track.

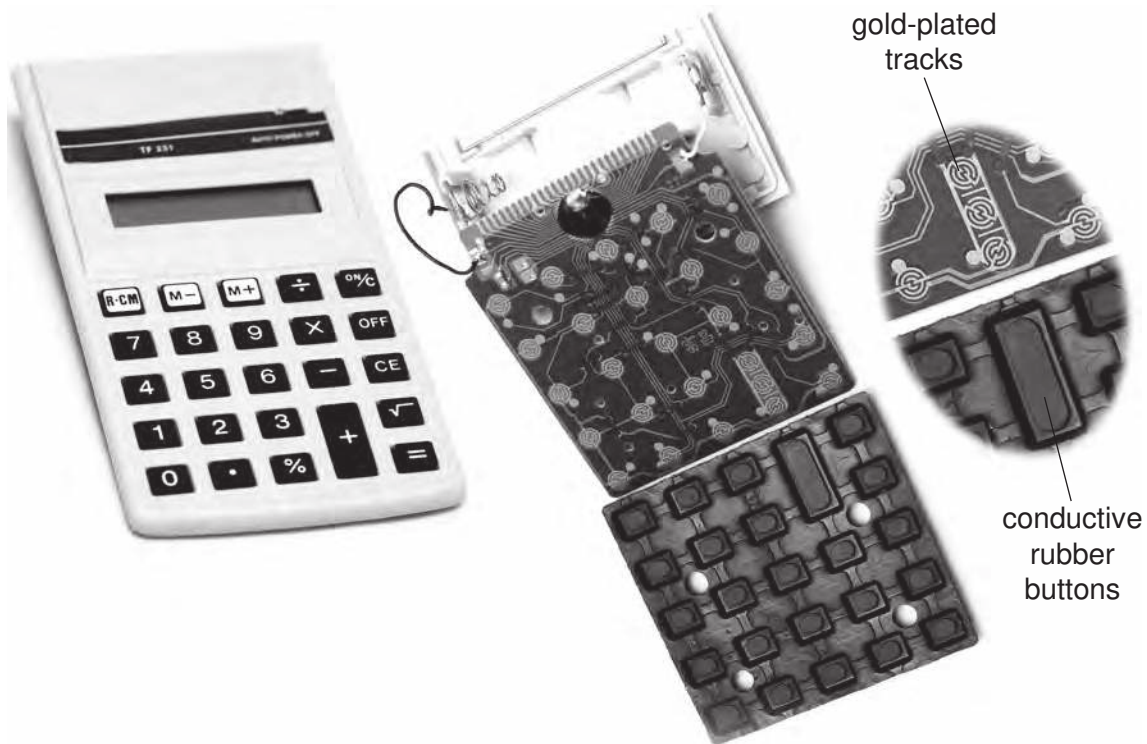

Fig. 19

Explain why this system is used rather than mechanical switches with metal contacts.

.....
.....
..... [2]

(b) A radio-controlled toy car can be made to reverse when a push-to-make switch, **SW1**, connected to the coil of a DPDT relay, is pressed. The circuit is shown in Fig. 20.

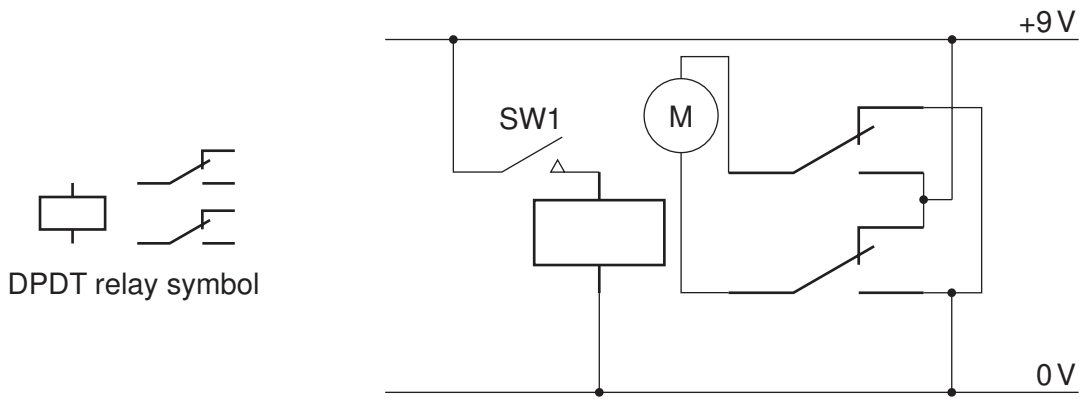

Fig. 20

(i) Describe how the circuit causes the motor to change direction.

.....

 [2]

(ii) State **one** advantage, in addition to reversing the motor, that connecting through a relay will give.

..... [1]

(c) LEDs of different colours are commonly used in electronic circuits.

(i) State **two** other ways in which LEDs can differ.

1
 2 [2]

(ii) Fig. 21 shows an LED circuit.

Calculate the value of R1 which will result in a current of 15 mA in the circuit.
The forward voltage of the LED is 1.8 V.

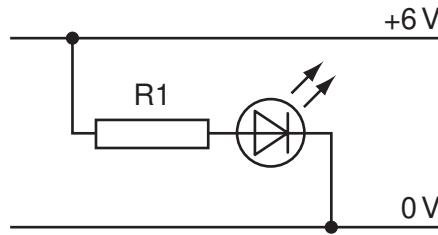

Fig. 21

.....

.....

..... [3]

(d) Fig. 22 shows a strain gauge and operating circuit.

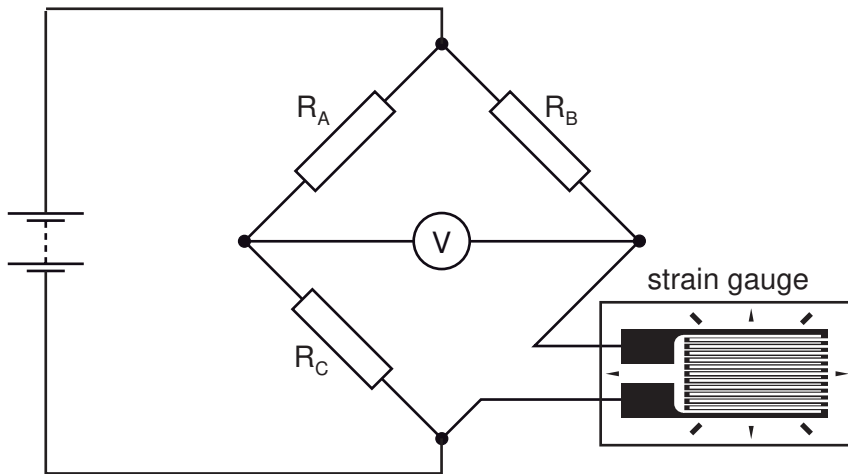

Fig. 22

(i) State the electrical property of a wire or foil strain gauge that will change in use.

..... [1]

(ii) Explain how the circuit in Fig. 22 can provide a changing voltage at the output.

.....

.....

..... [3]

- (e) In a quiz competition the first player to press their switch can answer the question. Fig. 23 shows a logic circuit that can detect which switch has been pressed first.

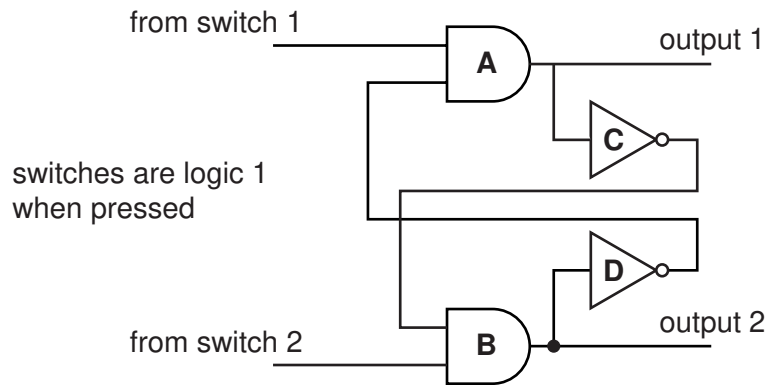

Fig. 23

- (i) State the names of the **two** types of logic gate used in the circuit.

1 2 [2]

- (ii) Explain why only output 1 will be at logic 1 when switch 1 has been pressed first.

.....

 [2]

- (iii) To show which player has pressed their switch first a light is connected to each of the outputs.

Complete the connections on the light switching circuit for output 1 in Fig. 24.

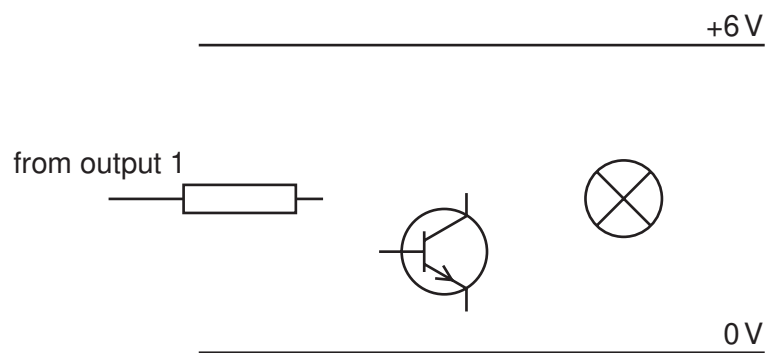

Fig. 24

[3]

BLANK PAGE

Permission to reproduce items where third-party owned material protected by copyright is included has been sought and cleared where possible. Every reasonable effort has been made by the publisher (UCLES) to trace copyright holders, but if any items requiring clearance have unwittingly been included the publisher will be pleased to make amends at the earliest possible opportunity.

University of Cambridge International Examinations is part of the Cambridge Assessment Group. Cambridge Assessment is the brand name of University of Cambridge Local Examinations Syndicate (UCLES), which is itself a department of the University of Cambridge.