



Cambridge International Examinations
Cambridge International General Certificate of Secondary Education

DESIGN AND TECHNOLOGY

0445/04

Paper 4 Systems and Control

For Examination from 2015

SPECIMEN MARK SCHEME

1 hour 15 minutes

MAXIMUM MARK: 50

This document consists of **7** printed pages and **1** blank page.

Section A

1

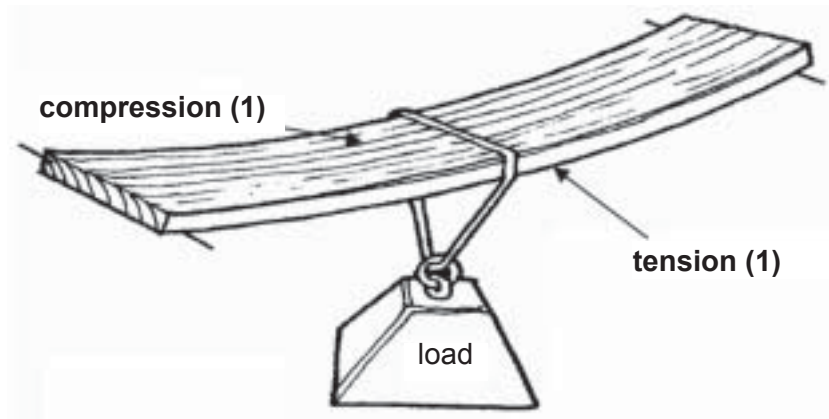

2 × (1)

[2]

2

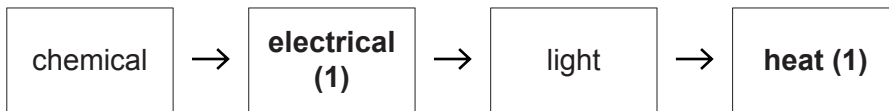

2 × (1)

[2]

3 Less slip/Positive drive

[1]

4 Tree/skeleton/shell

[1]

5 (a) A: Bevel gears (1)
 B: Worm and worm wheel (1)

[2]

(b) Change axis through 90°/change direction of rotation [1]

6 $V = IR$
 $R = V/I = (9 - 2)/0.01$ (1)
 $R = 7/0.01$ (1)
 $R = 700\Omega$ (1)

3 × (1)

[3]

7

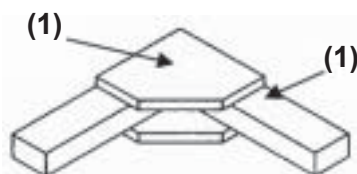

Gusset plate(s) shown (1), framework shown (1)

[2]

- 8 1 Linear (1)
- 2 Oscillating (1) [2]

9 Any **one** reason from the following list:

- plastics are good insulators
- plastics are suitable for injection moulding or vacuum forming processes, both of which are used for case manufacture
- plastics are available in different colours so the case colour can be changed quickly, most plastics can be recycled after use
- the waste from manufacture can be recycled. [1]

- 10 **A:** 1st order (1)
e.g. See-saw (1) [2]
- B:** 3rd order (1)
e.g. Fishing rod (1) [2]

11

Letter from diagram	Building component
C	Cantilever beam
B	Tie (Member in tension)
A	Strut (Member in compression)
D	Simply supported beam

4 × (1) [4]

[Total marks: 25]

Section B

- 12 (a) Any **three** stages from the following list:
- Trigger pin (2) goes low and circuit is triggered
 - C1 charges
 - LED switches on
 - C1 discharges during timing period
 - LED switches off.
- [3]

(b) The time delay is changed by altering the value of **C1** or **R2**. [2]

(c) **R3** is a current limiting (1) resistor for the LED (1). [2]

(d) *Name:* Push to make (PTM)

Reason for selection: Momentary action (1)
Cannot stick 'on' (1)
Easy to operate (1)

(e) (i) **RLA1** is a relay (SPDT). (1)

Interfaces (1) between low current and high current circuits (1)
allows high power devices to be controlled by low power processors (1) [4]

(ii) **D1** is a diode (1)

To protect the transistor (1) from back emf (1) [3]

(f) (i) **Gate 1** is an AND gate. (1)

Gate 2 is a NAND gate. (1) 2 × (1) [2]

(ii)

correct signals are logic 1

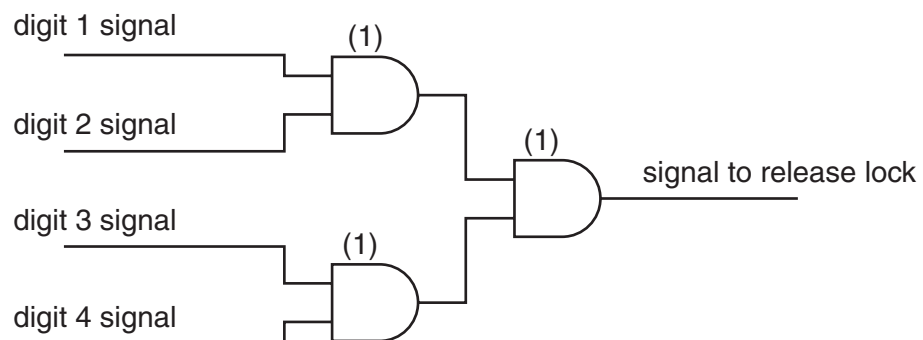

(iii) Segments for number two are **a, b, g, e, d** in any order.

Accept responses that show the segments shaded as below.

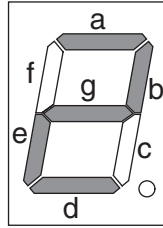

[1]

(iv) Modelling can be carried out using:

- real components (1) on a breadboard (1)
- simulated components (1) on simulation software (1)

2 × (1) mark for clear description.

[2]

[Total marks: 25]

- 13 (a) (i) **Static loading:**
A fixed value load (1) that does not move (1)

Example:

Roof tiles on the truss (1)

[3]

- (ii) **Dynamic loading:**
A variable value load (1) that is moving (1)

Example:

Builder walking about on roof/wind blowing against roof (1)

[3]

- (b) Triangulation (1) promotes rigidity (1)

[2]

- (c) $L + R = 100 \text{ kN}$

$$R \times S = S/2 \times 100 \quad (1)$$

$$2R \times 2S = S \times 100$$

$$2R = S/2S \times 100$$

$$R = 100/2 = \mathbf{50 \text{ kN}} \quad (1)$$

$$L = 100 \text{ kN} - 50 \text{ kN} = \mathbf{50 \text{ kN}} \quad (1)$$

[3]

- (d)

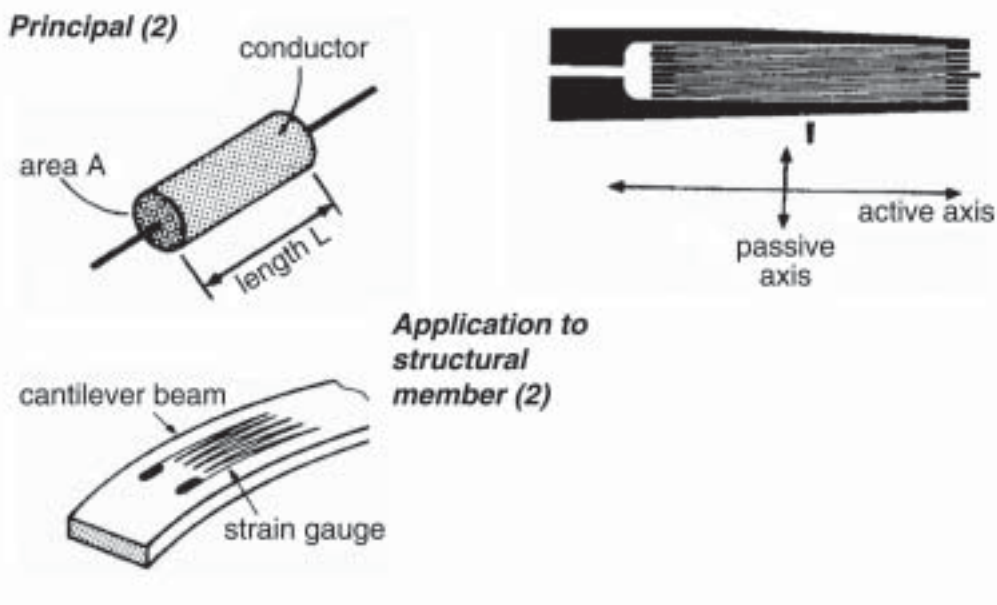

[4]

(e)

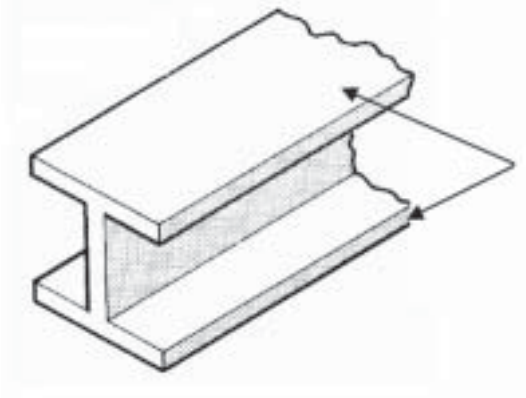

The web of the **I** beam resists shear (1),
the flanges resist bending (1)
Clear drawing (1)

3 × (1) [3]

- (f) (i) **A** Plastic region (1)
- B** Elastic region (1)
- C** Break point/Fracture point/Failure point (1) [3]
- (ii) Strain = change in length / original length
Change in length = strain × original length (1)
Change in length = $5 \times 10^{-3} \times 300$ (1)
Change in length = 1.5 mm (1)
New length = $300 + 1.5 = 301.5 \text{ mm}$ (1)
(Correct answer with no working 4 marks.) [4]

[Total marks: 25]

- 14 (a) Increase the speed (1) as driver pulley is bigger than driven (1) [2]
- (b) The direction is the same (1) as the driver due to belt drive (1) [2]
- (c) VR = Diameter Driven/Diameter Driver (1)
VR = $20 \text{ mm}/40 \text{ mm} = 0.5$ (1)
VR = Speed Driver/Speed of driven
Speed Driven = Speed driver/VR = $150 \text{ rpm}/0.5 = 300 \text{ rpm}$ (1) [3]
- (d) (i) Drilling machine/Lathe [1]
- (ii) To improve grip (1) to improve location (1)
Allow marks for other valid points. 2 × (1) [2]
- (iii) To allow speeds (1) to be varied (1) without having to change
the motor speed (1) 3 × (1) [3]

(e) (i)

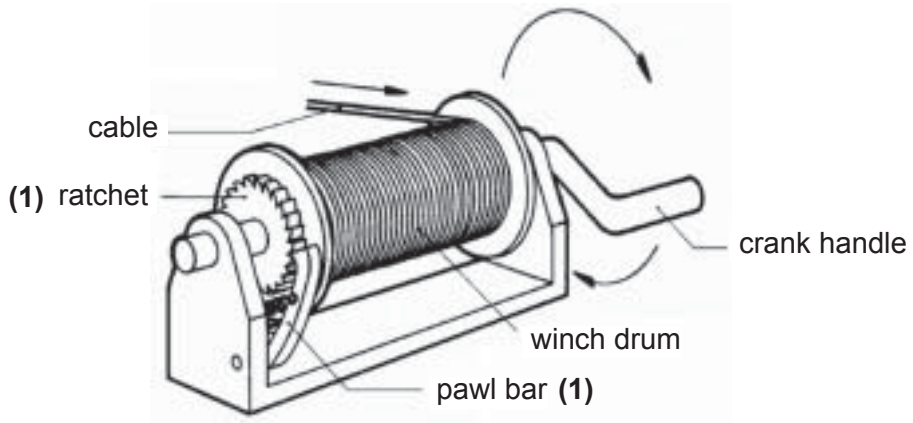

2 × (1) [2]

(ii) Fishing reel/ratchet screwdriver/shaping machine [1]

(f) (i)

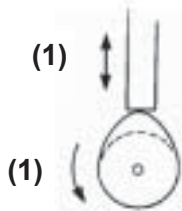

2 × (1) [2]

(ii) Motor car engine [1]

(iii) During this period the follower (1) does not move up or down (1) though the cam continues to rotate (1) 3 × (1) [3]

(iv)

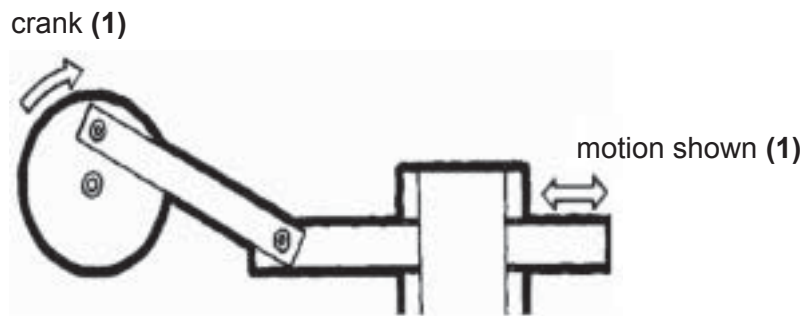

3 × (1) [3]

[Total marks: 25]