

Question 1

Orthographic views of the two parts of a battery operated toothbrush and a toothpaste dispenser are given below. A photograph of the items is given to the right. In the spaces indicated:

- (a) draw design sketches of a rack to hold the body of the toothbrush, **four** toothbrush heads and one toothpaste dispenser. The rack is to be:
- made of any suitable material;
 - suitable both for attaching to a vertical surface and for free-standing on a horizontal surface.
- It is expected that more than one idea will be investigated. [9]

- (b) (i) using instruments, draw full size your chosen design for the rack. Your answer may be presented in **EITHER** isometric projection **OR** oblique projection **OR** estimated two-point perspective. You need not show the parts of the toothbrush and the toothpaste dispenser in your answer. [17]

- (ii) in the boxes provided:
- give the name of the projection you have used for your answer; [1]
 - give the material(s) from which the dispenser is to be made. [1]

- (iii) use colour and/or shading to enhance your drawing so that it is suitable for printing on the box in which the rack is to be sold. [6]

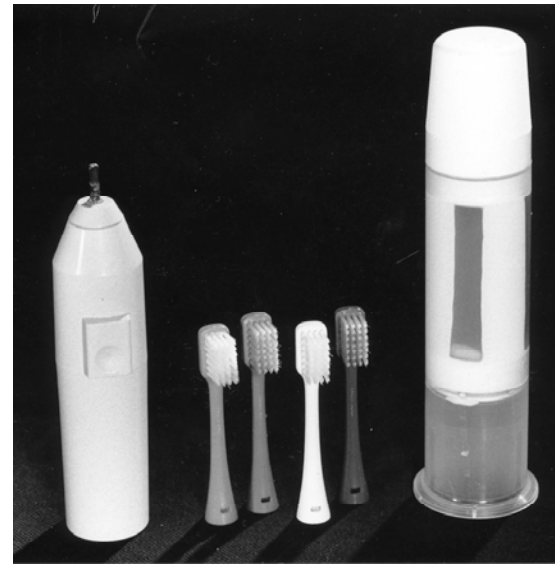

Answer (a) here

TOOTHBRUSH HEAD

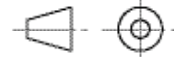
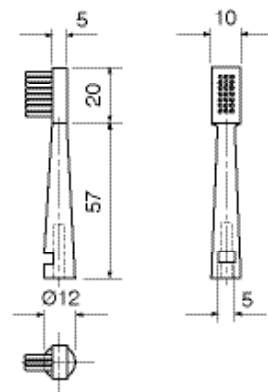

TOOTHBRUSH BODY

BODY

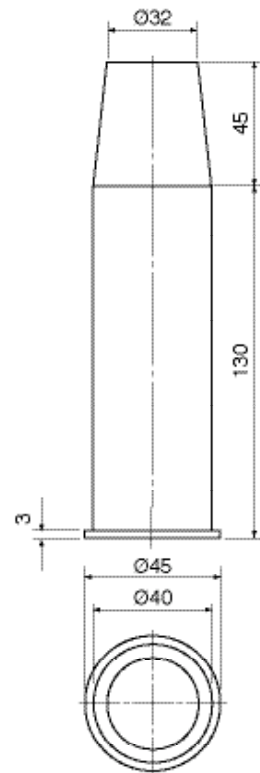
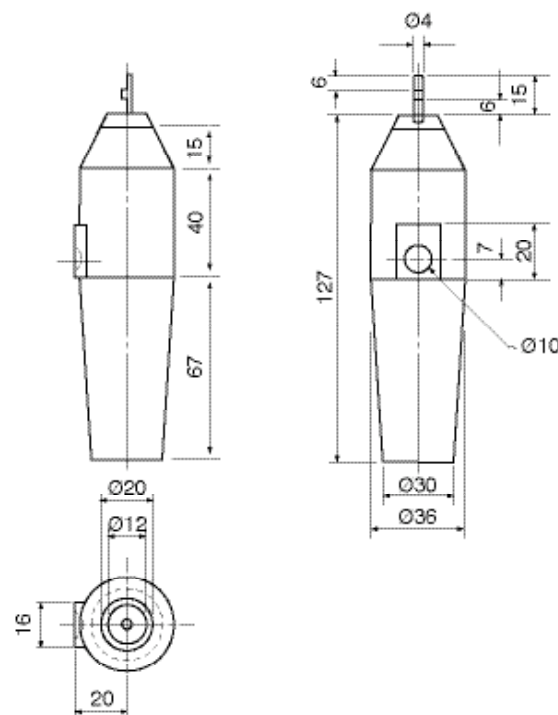

Answer (b) here

PROJECTION USED MATERIAL(S) USED

[Turn over

Candidate's Surname

Other Names

Centre Number

Candidate's Number

For
Examiner's
use

Question 2

Read all parts of the question before starting to draw.

Orthographic views and a pictorial view of a garden seat are given to the right. The three seat boards are attached to the four battens using countersunk head wood screws. The concrete supports are held in position between the battens using round-headed bolts, nuts and washers.

In the positions indicated:

- (a) colour and shade the given pictorial view of the seat to show that the boards and battens are made from wood and the supports are made from concrete. [6]
- (b) draw freehand sketches of your ideas for a design for a similar seat which has a back. Your design **must** include a modified shape for the concrete supports which will support the back. It is expected that more than one idea will be investigated.
Your sketches may be in either orthographic or pictorial form. Add notes to your sketches to explain your design. [12]
- (c) (i) using instruments, draw to a scale of 1:5 an end view of your chosen design for a seat with a back. The required view is indicated by the arrow on the given pictorial view. Do not colour or shade your answer. [12]
(ii) fully dimension the shape of the concrete support. [4]

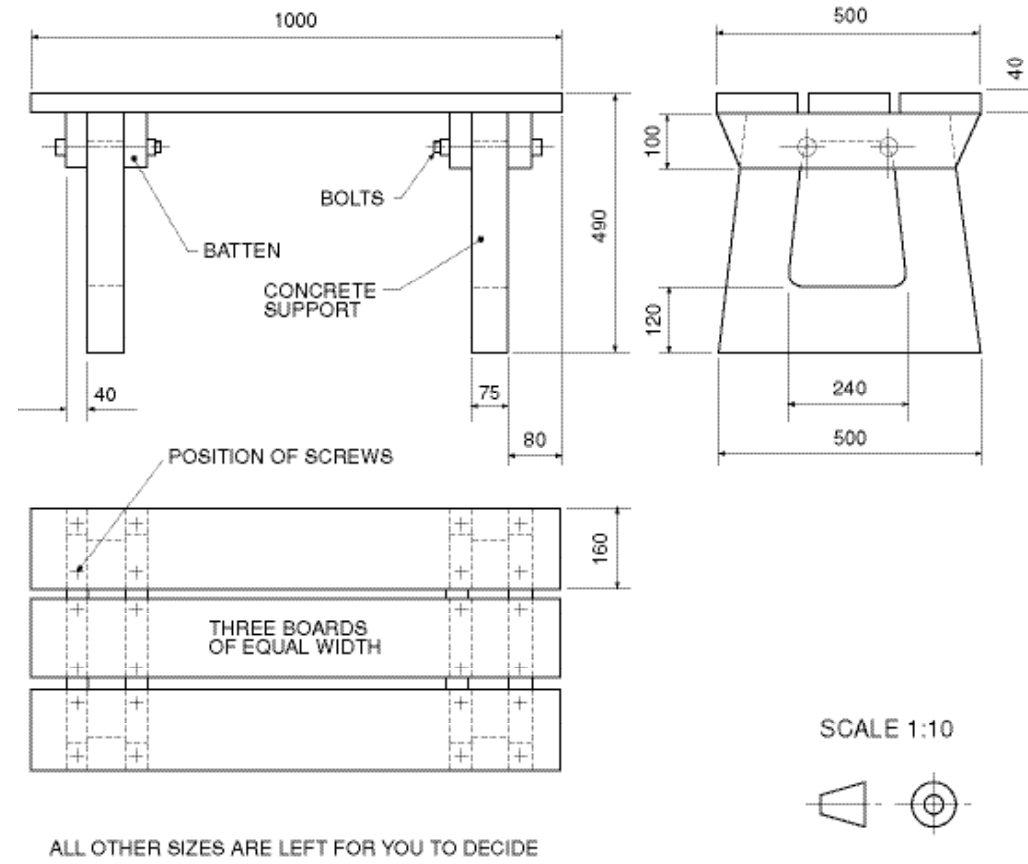

Answer (a) here

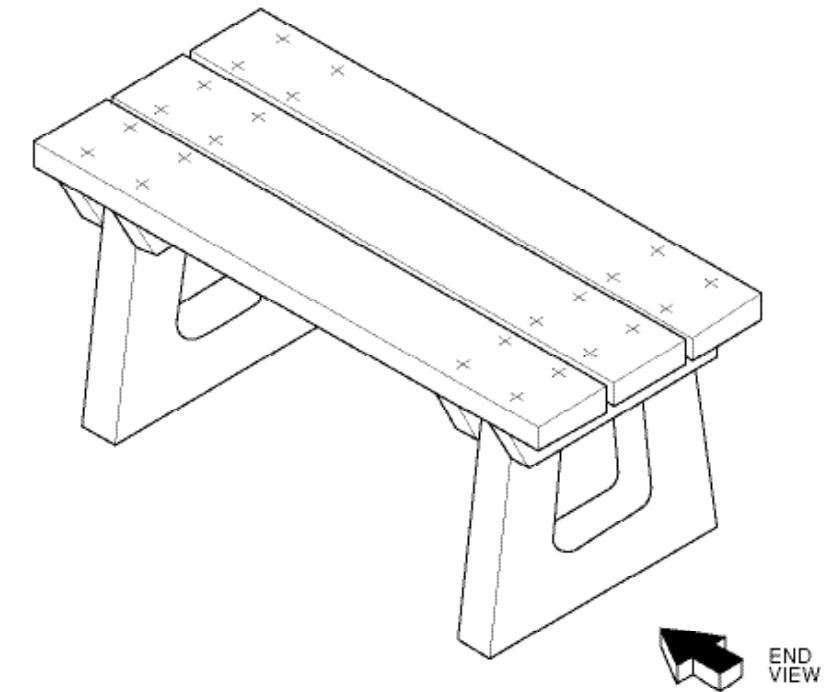

Answer (b) here

Answer (c) here

Question 3

Read all parts of the question before starting to draw.

An electronics company needs to represent the following figures in its annual report.

COMPANY TURNOVER FOR THE PERIOD 2000–2004					
DIVISION	2000 RS 000	2001 RS 000	2002 RS 000	2003 RS 000	2004 RS 000
TELEVISION	112	191	210	231	242
VIDEO	50	53	65	68	70
DVD	11	60	110	140	190
RADIO	75	76	88	91	94
COMPUTER	82	90	102	110	124
TOTAL FOR YEAR	330	470	575	640	720

In the spaces indicated:

- (a) draw a suitable graph, chart or diagram to show the total turnover of the company during the five year period given. Your answer should emphasise how well the company performed in 2004. [13]
- (b) draw a suitable chart to show the distribution of turnover between the five divisions in 2004. [12]
- (c) use colour, shading and appropriate symbols to enhance your answers to both (a) and (b). [8]

(a) TOTAL TURNOVER FOR PERIOD 2000–2004

(b) TURNOVER BY DIVISIONS 2004

Question 4

Orthographic views of a model spacecraft are given below. Parts A, B, C, D and G are made from coloured shiny plastics and parts E and F are made from black rubber.

- The model is assembled as follows:
- Parts A and B are glued together to form a hollow cylinder;
 - Parts C and D are glued together to form a truncated cone;
 - The truncated cone is glued to the top of the cylinder;
 - Part E is held in the bottom of the cylinder by friction;
 - Part F is held in the top of the truncated cone by friction;
 - The lug of each leg (Part G) is glued in a slot in the cylinder.

In the space to the right:

- (a) draw accurately a pictorial view of the assembled model spacecraft. The vertical centre line of the view and the position of the top of Part F are given. [27]
- (b) add colour, shading and additional features to enhance your answer. [6]

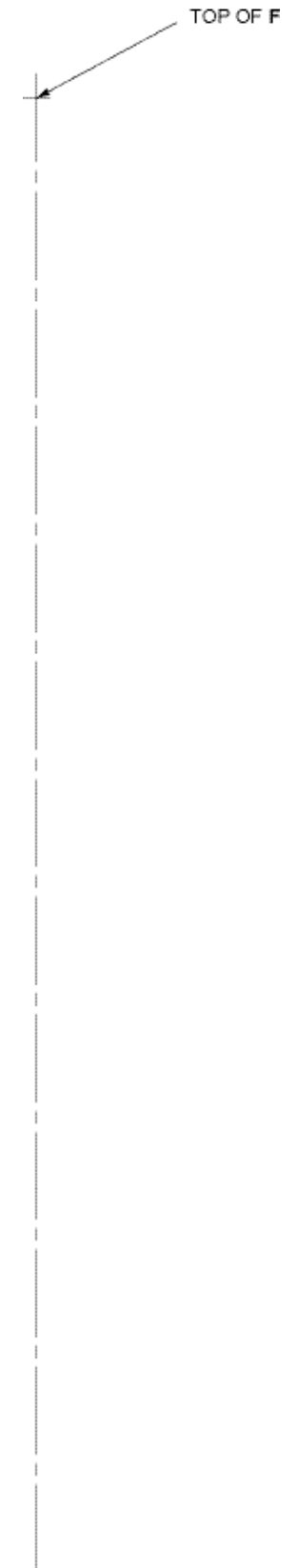
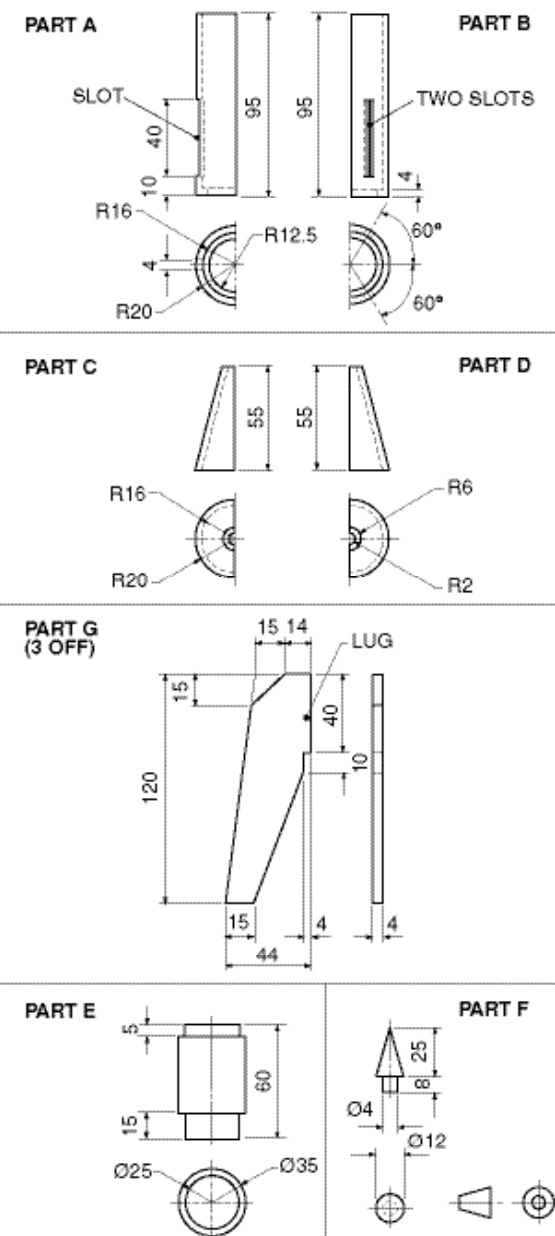

[Turn over

Candidate's Surname

Other Names

Centre Number

Candidate's Number

For
Examiner's
use

Question 5

A sheet metal flower holder is shown in the sketch to the right. It consists of three parts:

- the lid, which is semi-elliptical in section;
- the body, which is semi-cylindrical and 200 mm long;
- the base.

The body and the lid are hinged together as indicated.

Three incomplete orthographic views of the flower holder are given below.

- (a) Complete the end view by constructing the semi-ellipse **ABC**. [8]
- (b) Complete the front view by:
 - (i) drawing the two triangular notches in the base; [2]
 - (ii) constructing the line of intersection between the body and the base. [11]
- (c) Complete the plan by constructing the lines showing the ends of the lid. [6]
- (d) In the space indicated, sketch freehand a suitable addition to the flower holder which will make it easier to open the hinged lid. Add notes to your solution to explain your design. [6]

Ignore the thickness of the metal.
Do not draw the small holes in any view.

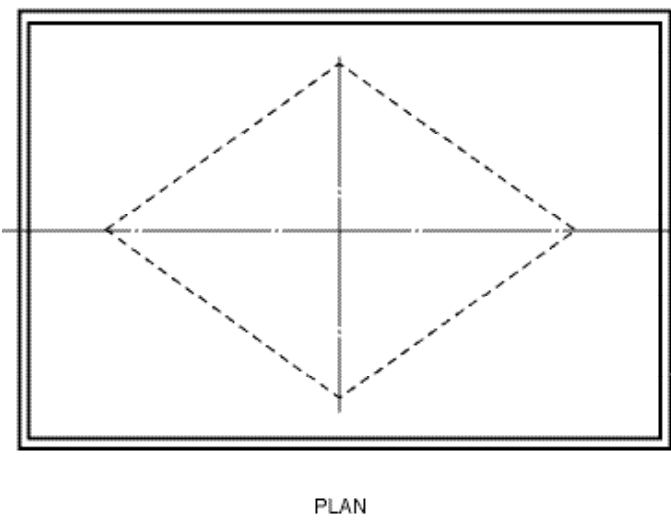
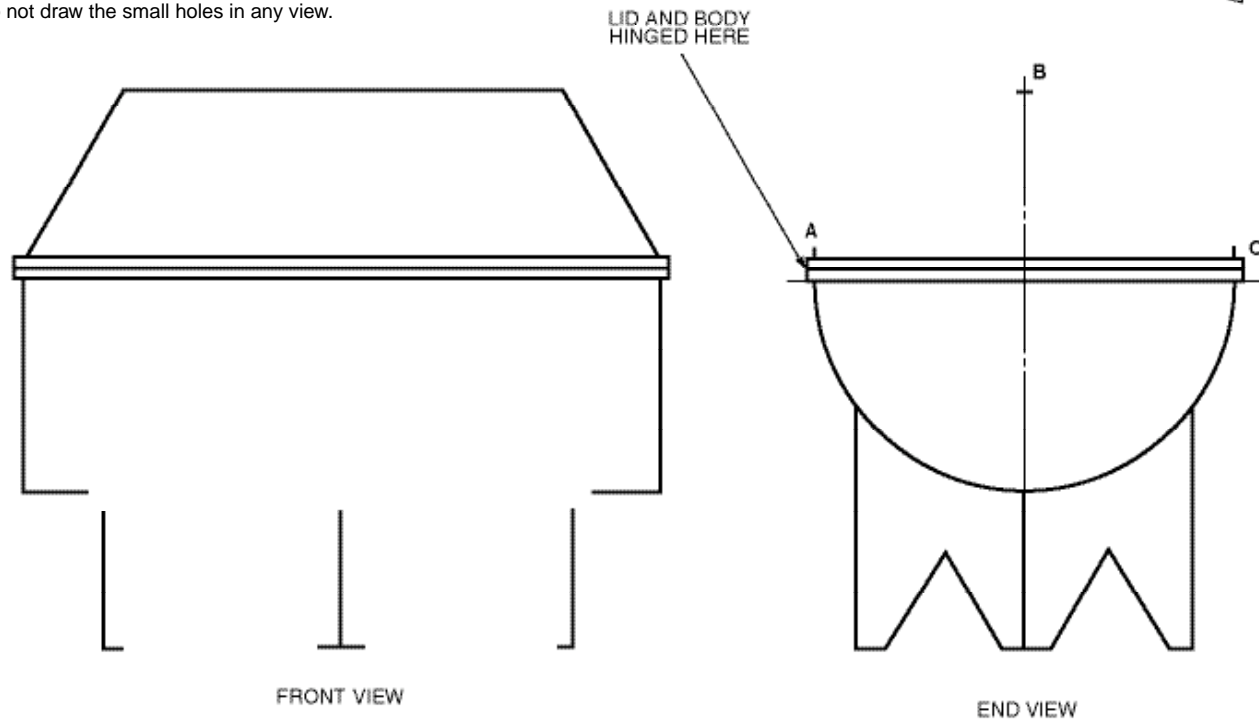
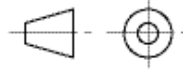
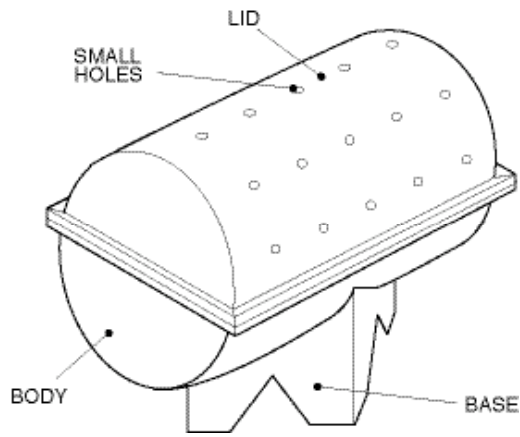

Answer (d) here

Question 6

A book of cut-out models for children includes a simple model of a police car. Orthographic views of the assembled model are given to the right. The model, which is open at the bottom, is to be made from a single piece of thin card. There is a regular five-pointed star inscribed in a circle on the roof of the model.

In the space below:

- (a) construct a one-piece development of the model police car. The roof has been drawn for you. Include all gluing flaps in your answer; [17]
- (b) construct the five-pointed star in the given circle; [4]
- (c) using a geometrical construction, draw the seven equal divisions on both sides of the development of the car; [3]
- (d) construct an ellipse, major axis 42 mm and minor axis 26 mm, centrally positioned on the rear of the car; [4]
- (e) add additional features to the model which would make it attractive to young children. [5]

Marks will be given for the effective use of colour. You need not colour the whole of your answer, but you must show what the final model will look like. [5]

