

**SECTION 1: Answer one question from this section.**

**Question 1**

A sketch of a hammer and peg toy is shown on the right. The toy consists of a frame, three pegs and a hammer.

(a) In the space below, complete to a scale of 1:2 the following orthographic views of the **frame** of the toy.

(i) A front view in the direction of **FE**. [4]

(ii) An end view in the direction of **EE**. [2]

(iii) A plan in the direction of **P**. [5]

Do **not** show any hidden detail.

(b) Add **three** dimensions to the orthographic views. [2]

(c) Add the projection symbol in the box provided. [2]

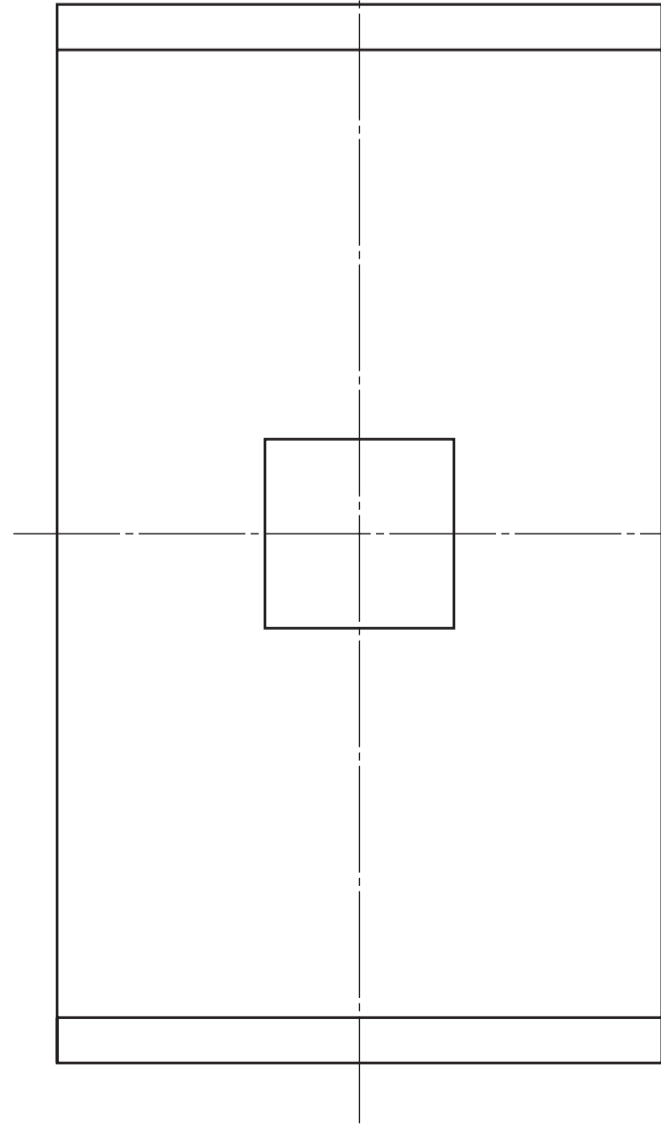
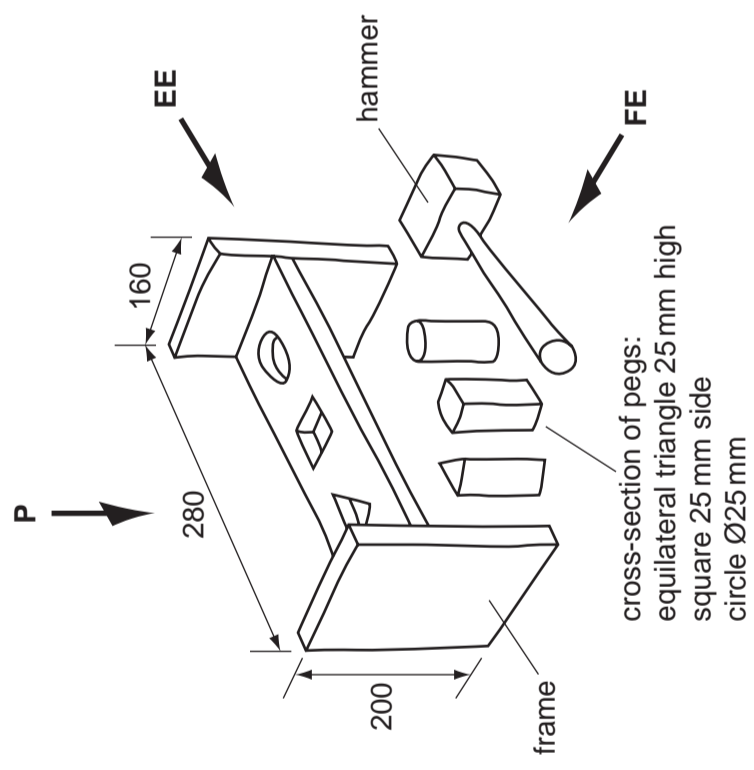

plan

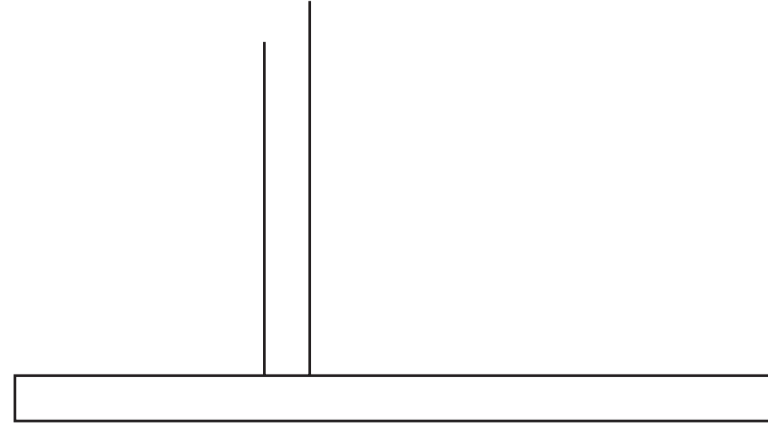
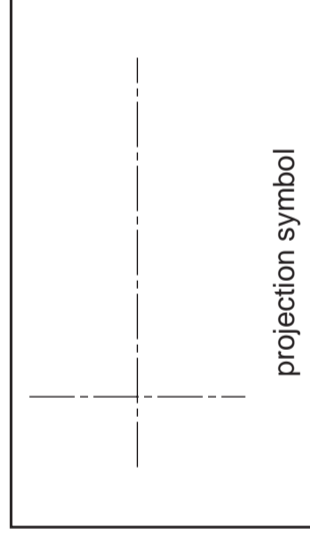

front view

end view

(d) Orthographic views of the wooden hammer are shown on the right. Draw the full-size **isometric** view of the wooden hammer from the given start point **A**. [8]

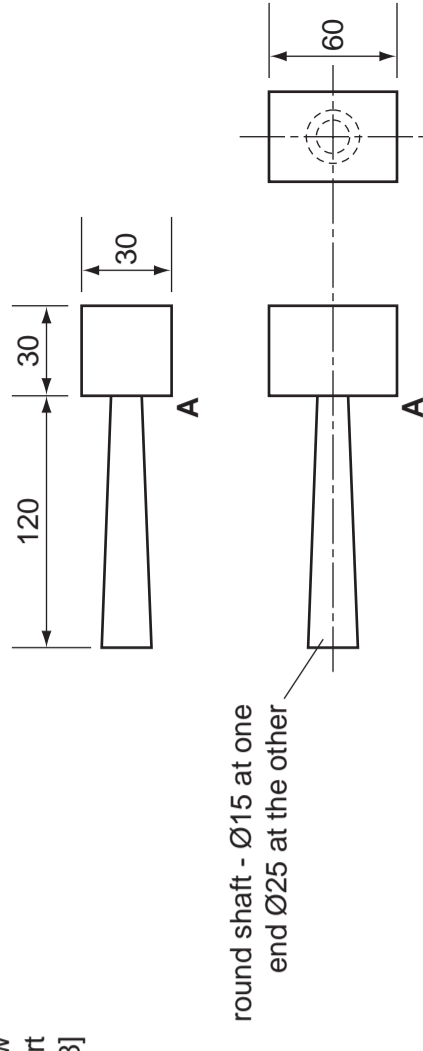

round shaft - Ø15 at one end Ø25 at the other

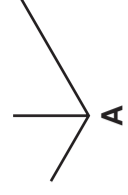

(e) Sketches of two pegs are shown below. Add rendering to make:

(i) the square-shaped peg look like wood; [3]

(ii) the circular-shaped peg look like plastic. [2]

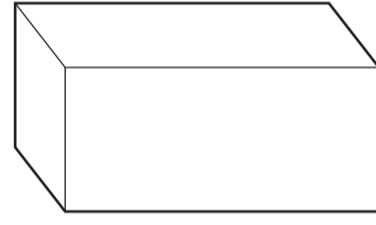

square-shaped peg



circular-shaped peg

(f) A self-adhesive sticker is to be attached to the end of the frame of the toy. The sticker is to include the word **HARRY**.

Add the word **HARRY** to the sticker below. [2]

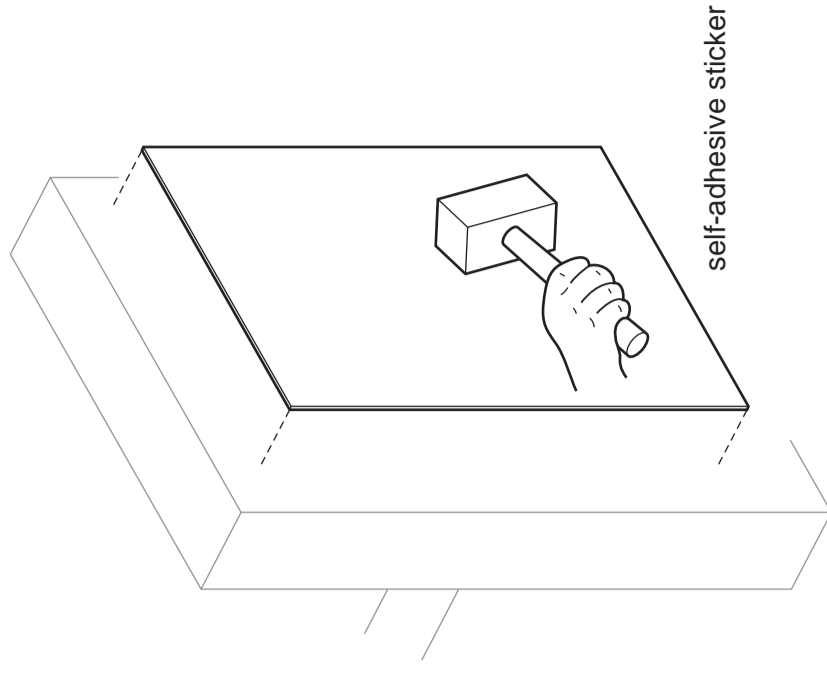

[Turn over]



Examiner's use only

**Question 2**

A set of cube-shaped children's building blocks is shown on the right. The blocks have letters on them so that children can use them to make words.

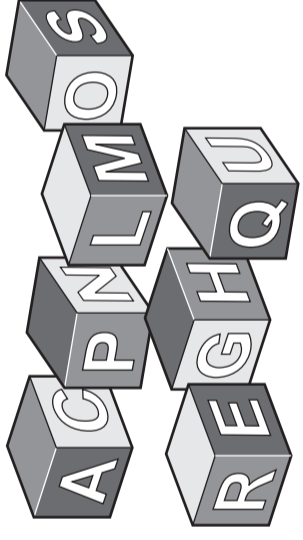

(a) (i) Name the drawing projection method used in the table below to show the building blocks. [1]

..... [1]

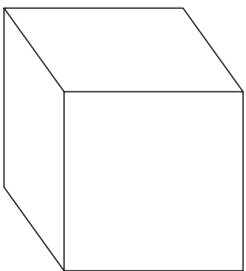
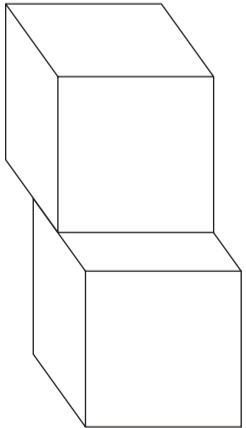
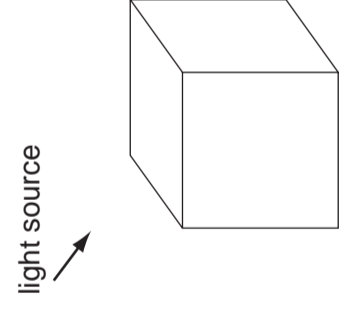
|   |   |   |
|---|---|---|
|  |  |  |
| shading   | thick and thin line technique   | shadow  |

(ii) Complete the drawings in the table above to show the **three** stated methods of enhancing the appearance of the building blocks. [6]

(b) In the space below, complete the estimated two-point perspective drawing of **one** cube-shaped building block. Add a letter **L** to one surface of the building block. [6]

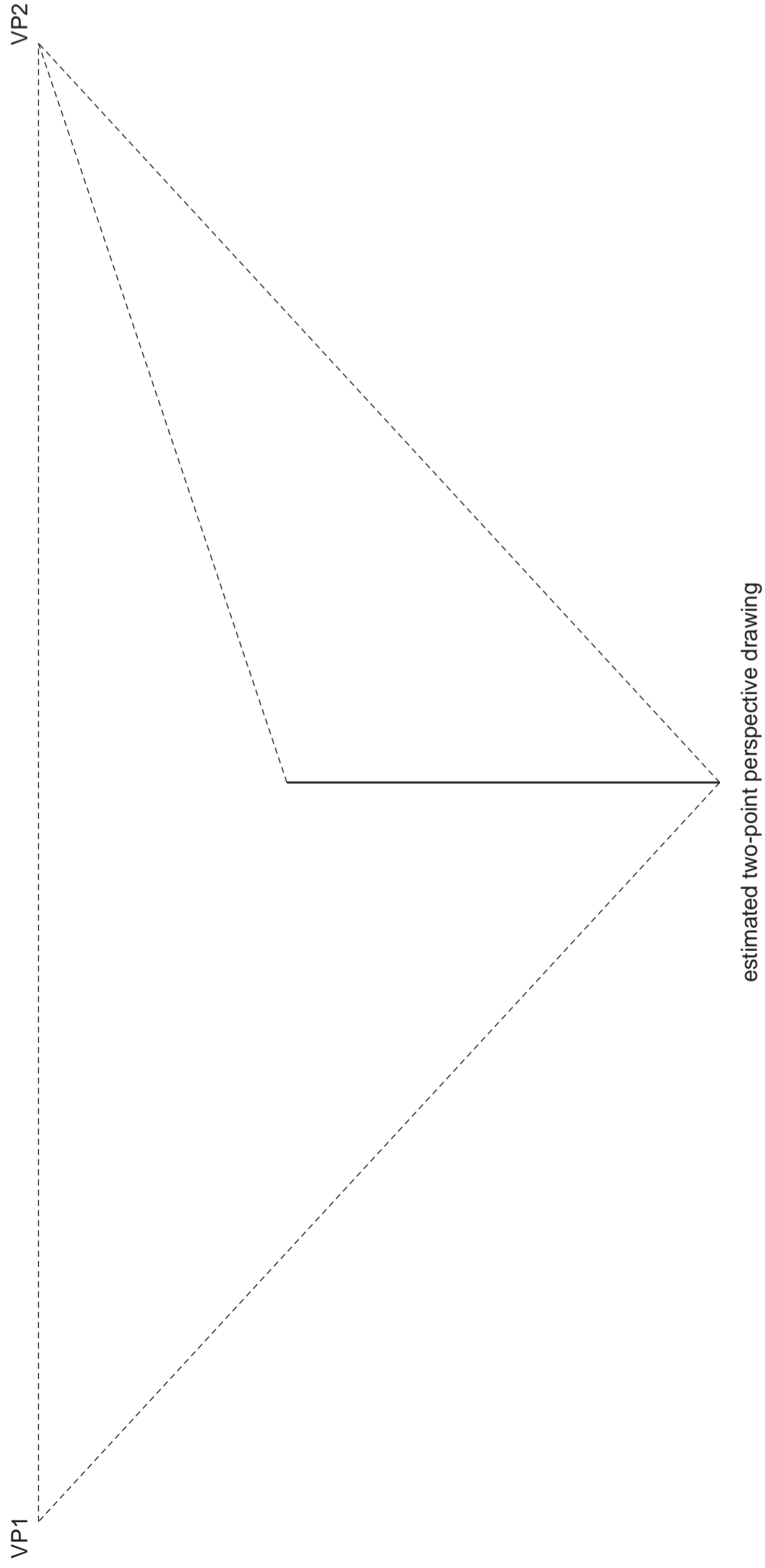

(c) The cube-shaped building blocks are 75 mm square. A set of 24 building blocks is packaged in a rectangular cardboard box.

(i) Complete the table below to show **three** different ways of stacking the 24 blocks ready to be packaged. [5]

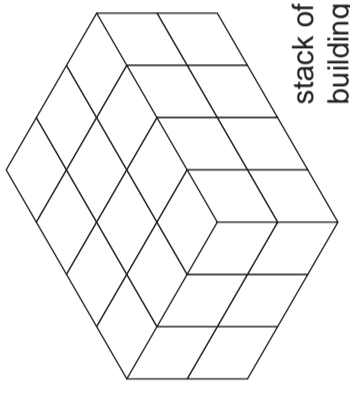
|   |        |        |        |
|---|--------|--------|--------|
|  | idea 1 | idea 2 | idea 3 |
| stack of building blocks<br>4 × 3 × 2   |        |        |        |

(ii) In the space on the right calculate the length, width and height of the box required to hold the stack of building blocks shown in idea 1. [3]

size of box:

length =

width =

height =

(iii) Complete the drawing below to show a scale 1:5 drawing of the development (net) required to make the box shown on the right for the stack of building blocks shown in idea 1. Include all fold lines and glue tabs. [9]

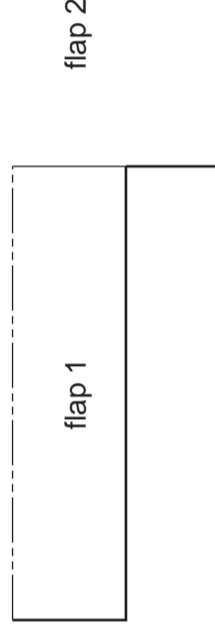
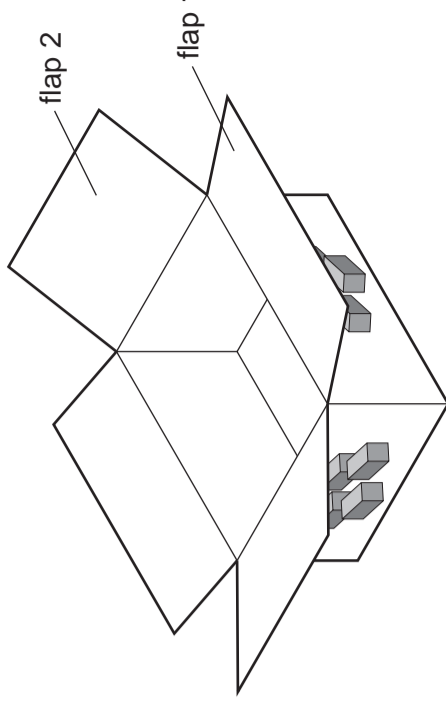

**SECTION 2:** Answer **two** questions from this section.

**Question 3**

Sketches of an egg-shaped cam and cam follower are shown on the right. As the cam rotates, the cam follower moves up and down.

(a) In the space below, accurately draw a full-size view of the profile of the cam. [6]

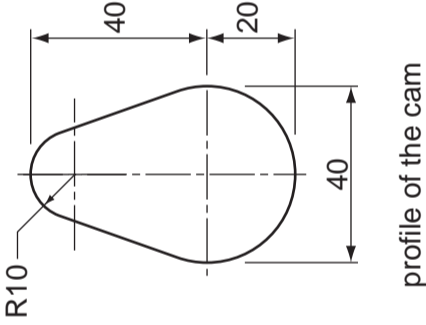
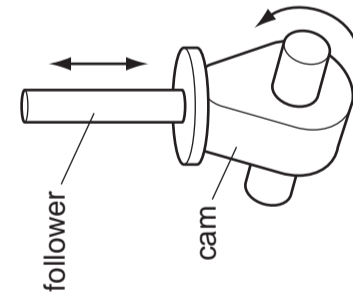
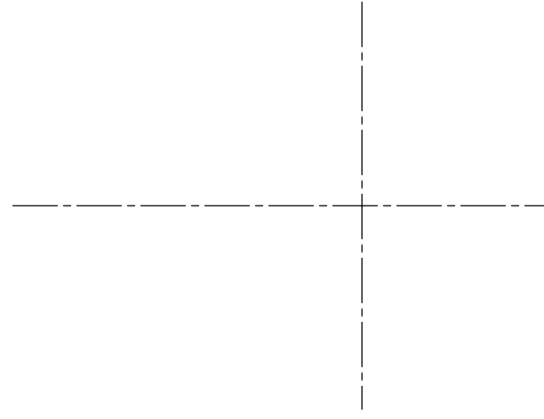

profile of the cam

(b) Complete the table below by:

(i) naming the first and last cam profile; [2]

(ii) drawing the profile of the second and third cam. [5]

|       |                        |   |       |
|-------|------------------------|---|-------|
|       |                        |   | ..... |
| ..... | eccentric cam<br>(Ø40) | elliptical cam<br>(major axis 60 mm minor axis 40 mm) | ..... |

(c) Drawings of a pull-along ladybird toy are shown on the right.

The toy is made from a body, an axle and two egg-shaped cams that are used as wheels. In the boxes below:

(i) draw a full-size isometric view of the body of the ladybird toy from the start point A. Estimate any dimensions not given; [7]

(ii) sketch an exploded view of the ladybird toy. [5]

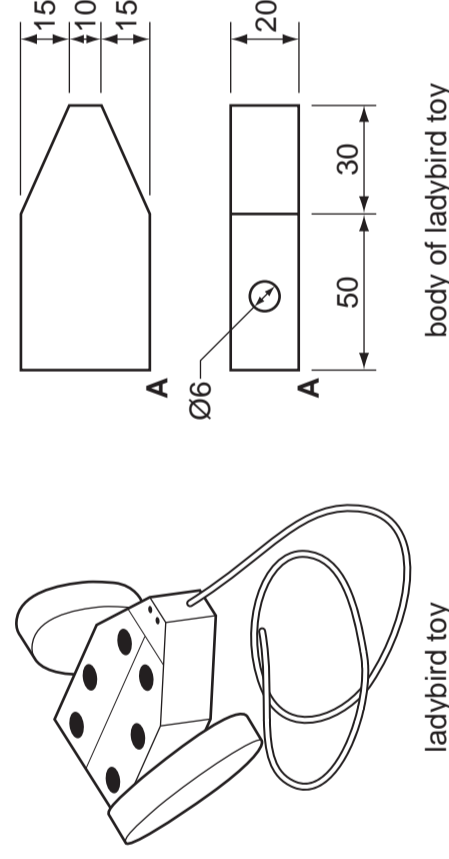

ladybird toy

body of ladybird toy

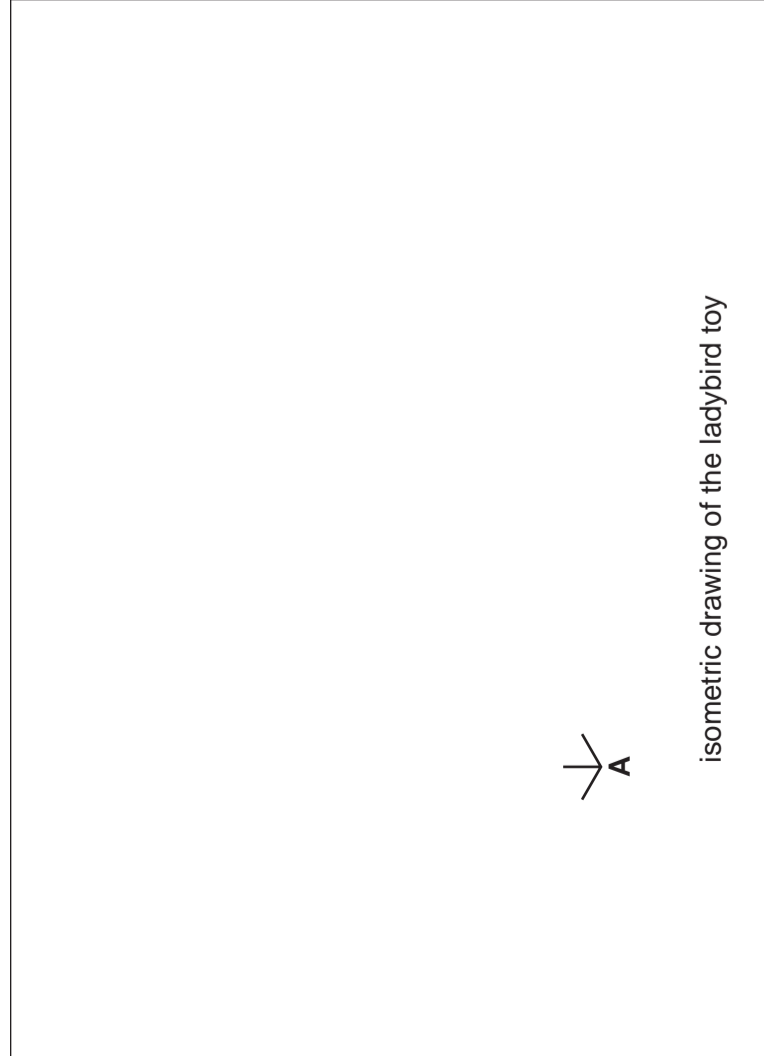

isometric drawing of the ladybird toy

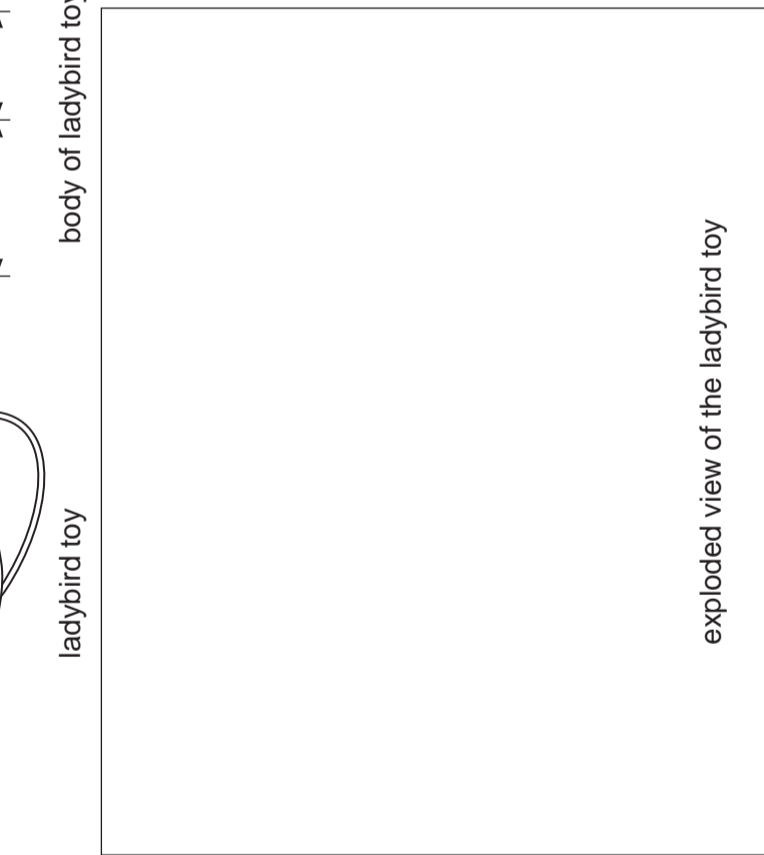

exploded view of the ladybird toy

**Question 4**

A partly completed view of a clock face that is used to help children tell the time is shown on the right.

(a) Complete the drawing of the clock face by adding the centres of eleven more circles that would represent the numbers. [6]

(b) The clock face is made from 10 mm thick foam board and held in an upright position on the clear acrylic stand shown below. Render the stand to look like clear acrylic. [3]

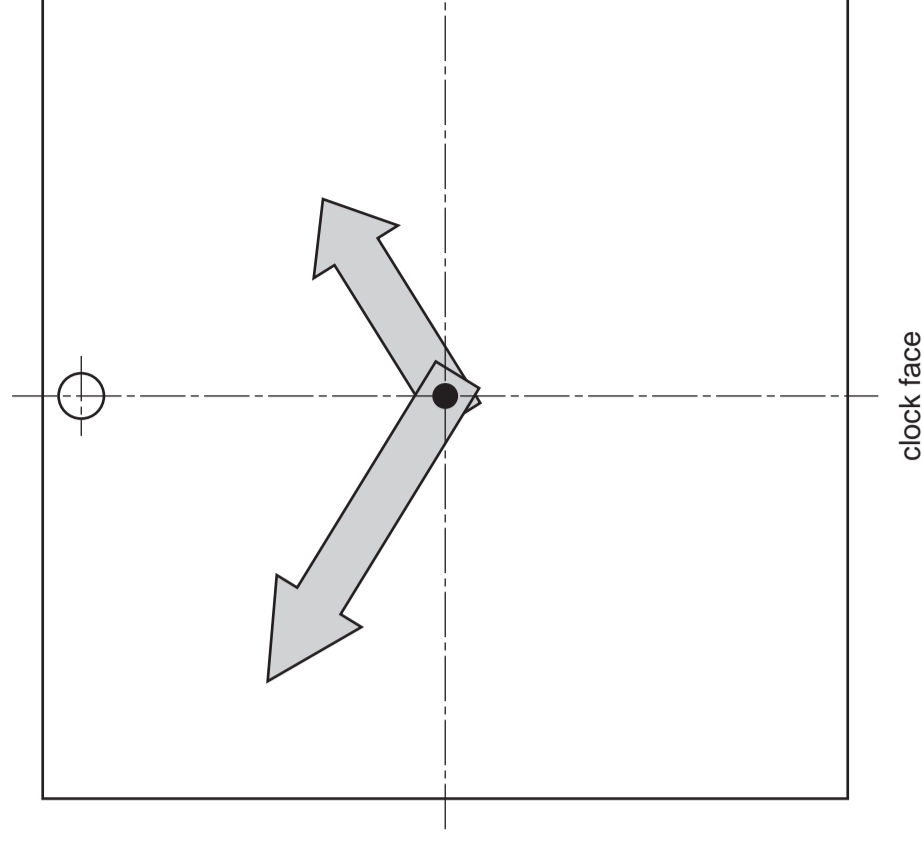

clock face

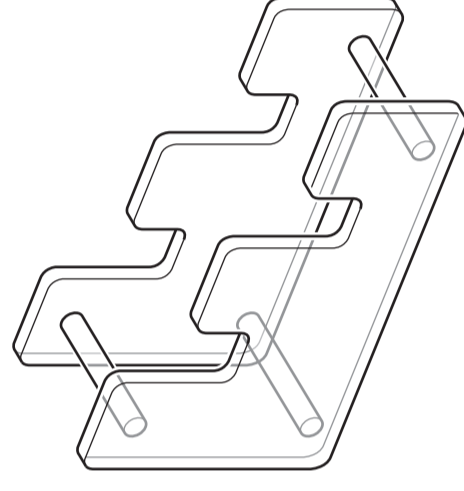

clear acrylic stand

(c) Colour is to be used to enhance the appearance of the clock face. In the space below, use sketches and notes to:

(i) show a suitable colour scheme for the clock face; [2]

(ii) justify the choice of colours. [2]

(e) An instruction leaflet is included with the clock. The leaflet contains a flow chart with the following stages for assembling the clock.

- 1 Unpack the pieces.
- 2 Stick on the circles.
- 3 Fasten the hands to the correct tightness.
- 4 Place the face on the stand.

Complete the flow chart below to show the stages in assembling the clock. Include a feedback loop to show customers what to do if the hands do not turn. [8]

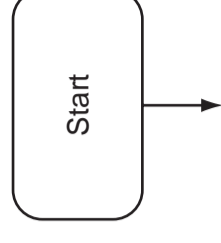

(d) A plastic screw-bolt is used to hold the hands to the clock face so that they can rotate. In the space below, sketch the sectional view of the hands being held by the screw-bolt to the clock face. [4]

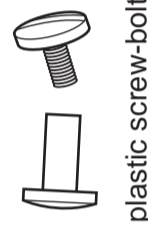

plastic screw-bolt

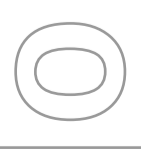

UNIVERSITY OF CAMBRIDGE INTERNATIONAL EXAMINATIONS  
General Certificate of Education Ordinary Level

CDT: DESIGN AND COMMUNICATION

Paper 1

7048/01

October/November 2013

2 hours 30 minutes

plus 15 minutes reading time

No Additional Materials are required

© UCLES 2013

**SHEET 2 OF 2 (SECTION 2)**  
Write your surname, other names, Centre number and candidate number in the spaces provided.

Answer **one** question only from Section 1 (Questions 1 and 2).

Answer **two** questions only from Section 2 (Questions 3 to 6).

Answer the questions in the spaces provided.

All construction and projection lines must be clearly shown.

The number of marks is given in brackets [ ] at the end of each question or part question.

Candidate Surname .....

Other Names .....

Centre Number .....

Candidate Number .....





[Turn over



**Question 5**

(a) Dice and spinners are often used in children's board games to show numbers.

Answer the questions in the table below.

|   |  |  |   |
|---|--|--|---|
| <br>dice 1 | <br>dice 2            | <br>spinner                     | <br>shaker cup |
| Use sketches and notes to show how a stencil would be used to add the numbers to dice 1. [3]  | Name the shape of dice 2.<br>..... [1]<br><br>State the number of surfaces that dice 2 has.<br>..... [1] | Name the shape of the spinner.<br>..... [1]<br><br>Give a benefit of making the spinner from plastic.<br>..... [1] |   |

(b) The results of 36 throws of dice 1 are shown in the table below.

Draw a pie chart on the centre lines below to show the results of the 36 throws. Use colour and labels to enhance your chart. [6]

|                        |   |   |   |   |   |   |
|------------------------|---|---|---|---|---|---|
| Number on dice         | 1 | 2 | 3 | 4 | 5 | 6 |
| Number of times thrown | 6 | 9 | 6 | 3 | 9 | 3 |

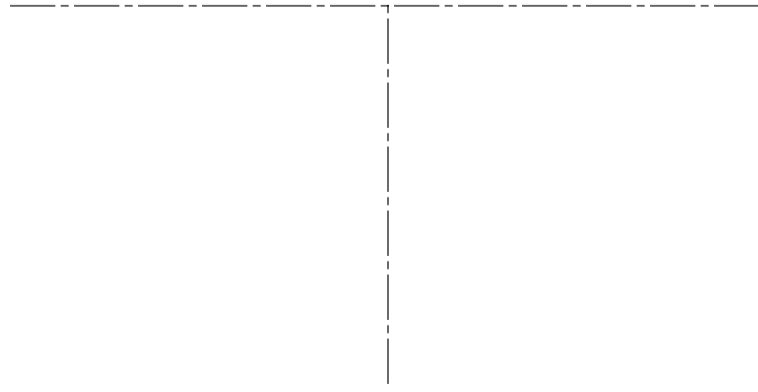

(c) Orthographic views of the shaker cup are shown below.

Draw a full-size planometric view of the cup on the centre lines below. [7]

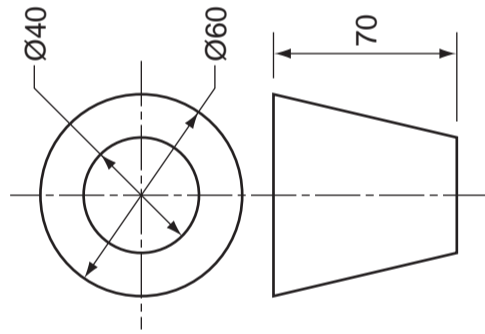

(d) The shaker cup is made from two pieces of card.

Use sketches to show the shape of each piece of card. Include all glue tabs and notes to describe how the two pieces will join together. [5]

**Question 6**

(a) A wooden toy lorry is shown on the right.

Complete the diagram below to show the path of the load (L) as the arm swings down and lowers it to the ground. [7]

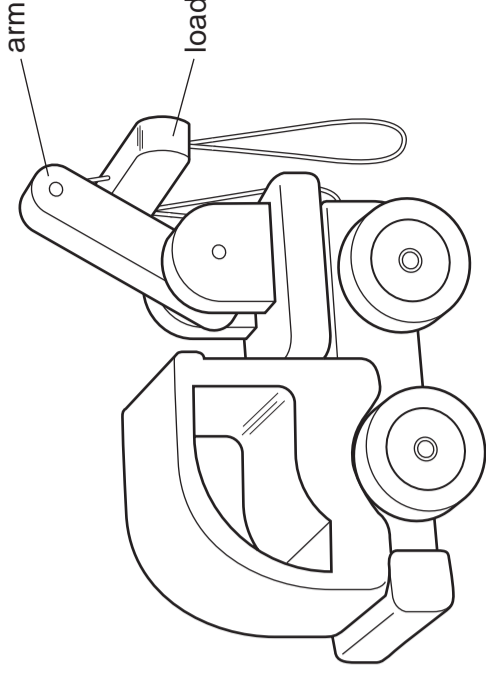
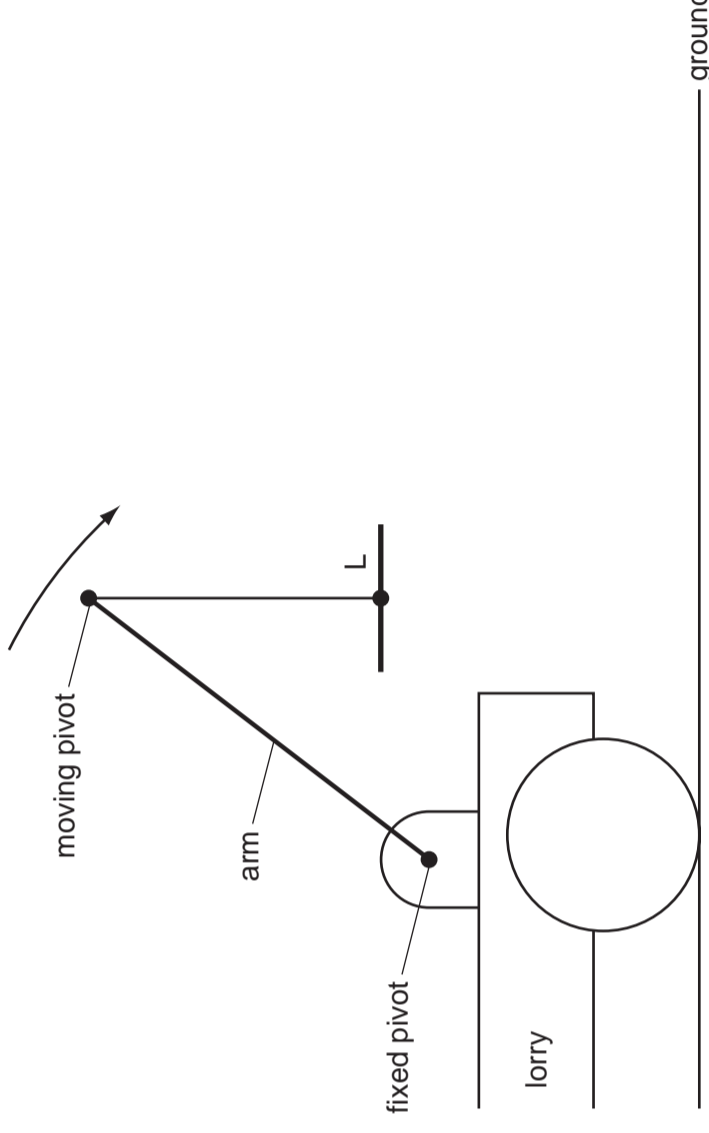

toy lorry

(b) Details of the lorry window are shown on the right.

Accurately complete the drawing of the shape of the window in the space below. [8]

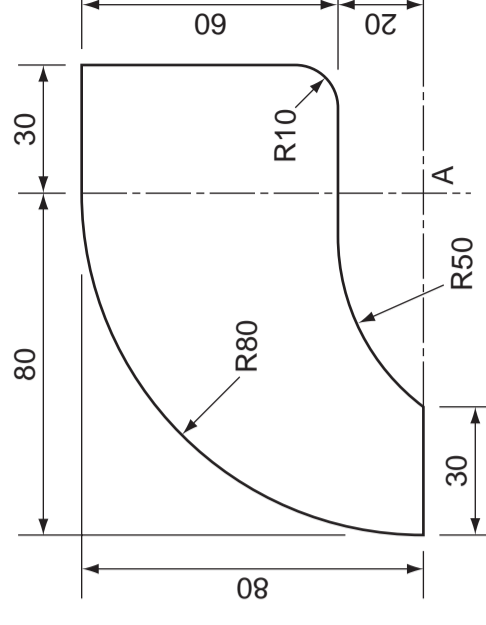

lorry window



(e) Sales of the toy lorry are shown in the table below.

Draw and label a bar chart to show the sales over a five year period. [5]

|       |      |      |       |      |      |
|-------|------|------|-------|------|------|
|       | 2008 | 2009 | 2010  | 2011 | 2012 |
| Sales | 6000 | 8000 | 10000 | 9000 | 9500 |

(c) Research is an important part of any design project.

State two methods of gathering research for the design of the toy lorry.

- ..... [1]
- ..... [1]

(d) Write three specification points for the toy lorry.

- ..... [1]
- ..... [1]
- ..... [1]

bar chart