



UNIVERSITY OF CAMBRIDGE INTERNATIONAL EXAMINATIONS
International General Certificate of Secondary Education

CANDIDATE
NAME

CENTRE
NUMBER

--	--	--	--	--

CANDIDATE
NUMBER

--	--	--	--

* 5 8 7 1 9 2 4 2 4 4 *

CAMBRIDGE INTERNATIONAL MATHEMATICS

0607/32

Paper 3 (Core)

May/June 2011

1 hour 45 minutes

Candidates answer on the Question Paper

Additional Materials: Geometrical Instruments
 Graphics Calculator

READ THESE INSTRUCTIONS FIRST

Write your Centre number, candidate number and name on all the work you hand in.

Write in dark blue or black pen.

Do not use staples, paper clips, highlighters, glue or correction fluid.

You may use a pencil for any diagrams or graphs.

DO NOT WRITE IN ANY BARCODES.

Answer **all** the questions.

Unless instructed otherwise, give your answers exactly or correct to three significant figures as appropriate.

Answers in degrees should be given to one decimal place.

For π , use your calculator value.

You must show all the relevant working to gain full marks and you will be given marks for correct methods, including sketches, even if your answer is incorrect.

The number of marks is given in brackets [] at the end of each question or part question.

The total number of marks for this paper is 96.

For Examiner's Use

--

This document consists of **17** printed pages and **3** blank pages.



Formula List

Area, A , of triangle, base b , height h .	$A = \frac{1}{2}bh$
Area, A , of circle, radius r .	$A = \pi r^2$
Circumference, C , of circle, radius r .	$C = 2\pi r$
Curved surface area, A , of cylinder of radius r , height h .	$A = 2\pi rh$
Curved surface area, A , of cone of radius r , sloping edge l .	$A = \pi rl$
Curved surface area, A , of sphere of radius r .	$A = 4\pi r^2$
Volume, V , of prism, cross-sectional area A , length l .	$V = Al$
Volume, V , of pyramid, base area A , height h .	$V = \frac{1}{3}Ah$
Volume, V , of cylinder of radius r , height h .	$V = \pi r^2 h$
Volume, V , of cone of radius r , height h .	$V = \frac{1}{3}\pi r^2 h$
Volume, V , of sphere of radius r .	$V = \frac{4}{3}\pi r^3$

Answer **all** the questions.

For
Examiner's
Use

- 1 (a) Write the ratio 12 : 20 in its simplest form.

Answer(a) : [1]

- (b) $x : 8 = 3 : 2$.

Find the value of x .

Answer(b) $x =$ [1]

- (c) Divide \$30 in the ratio 3 : 7.

Answer(c) \$: \$ [2]

- (d) Write the fraction $\frac{6xy}{3xy^2}$ in its lowest terms.

Answer(d) [2]

- (e) Work out $\frac{7}{19}$ of \$570.

Answer(e) \$ [1]

- (f) Calculate 15% of 60 kg.

Answer(f) kg [2]

- (g) Sam spends \$6 at a shop.

This is $\frac{3}{25}$ of Sam's pocket money.

Calculate Sam's pocket money.

Answer(g) \$ [2]

2 Ten students have the following shoe sizes.

33 36 36 33 35 37 33 32 38 38

(a) Find

(i) the mode,

Answer(a)(i) [1]

(ii) the median,

Answer(a)(ii) [1]

(iii) the range,

Answer(a)(iii) [1]

(iv) the upper quartile,

Answer(a)(iv) [1]

(v) the mean.

Answer(a)(v) [1]

(b)

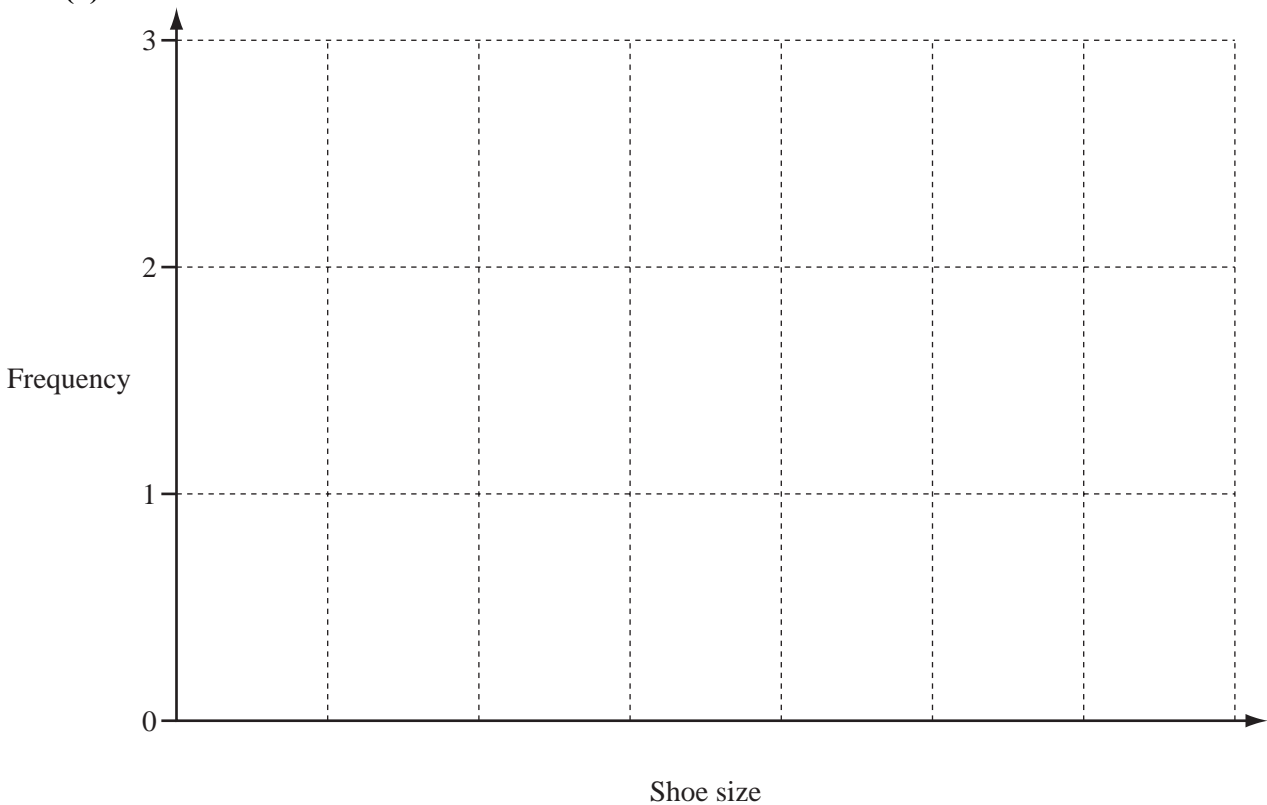

On the grid, draw an accurate bar graph to show the frequencies of the shoe sizes. [3]

(c)

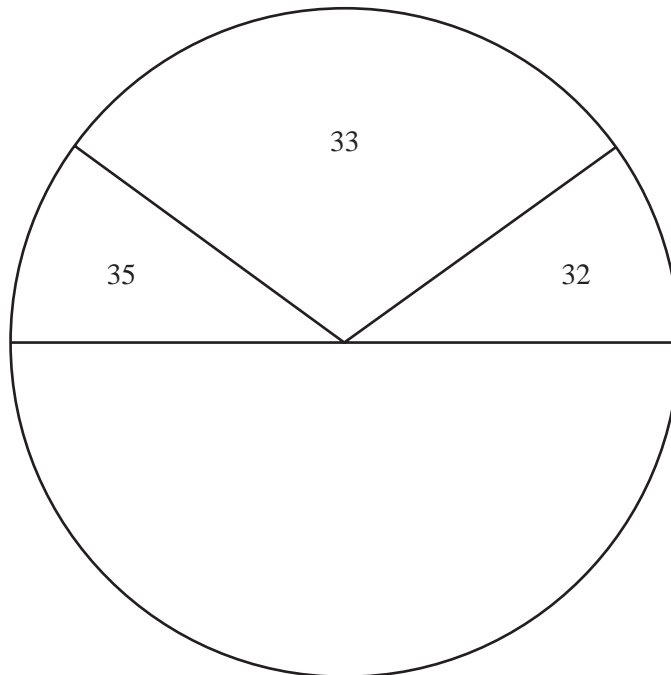

Complete the pie chart accurately to show the frequencies of the remaining shoe sizes.

Label your sectors clearly.

[3]

(d) Find the probability that a student chosen at random has a shoe size

(i) greater than 36,

Answer(d)(i) [1]

(ii) greater than 30.

Answer(d)(ii) [1]

(e) Find the percentage of those students with a shoe size greater than 32 who have a shoe size greater than 33.

Answer(e) % [2]

3 $U = \{ x \mid 1 \leq x \leq 10, x \in \mathbb{Z} \}$

$A = \{ \text{even numbers} \}$

$B = \{ \text{factors of 36} \}$

(a)

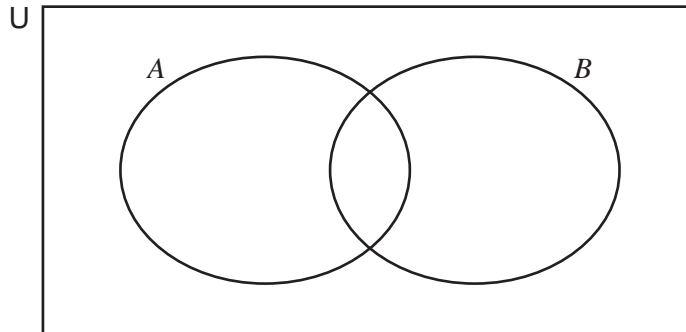

Write the ten members of U in the correct regions of the Venn diagram. [3]

(b) Complete the following.

(i) $A \cap B = \{ \dots \}$ [1]

(ii) $A \cup B = \{ \dots \}$ [1]

(iii) $A' \cap B = \{ \dots \}$ [1]

(iv) $n(B') = \dots$ [1]

4

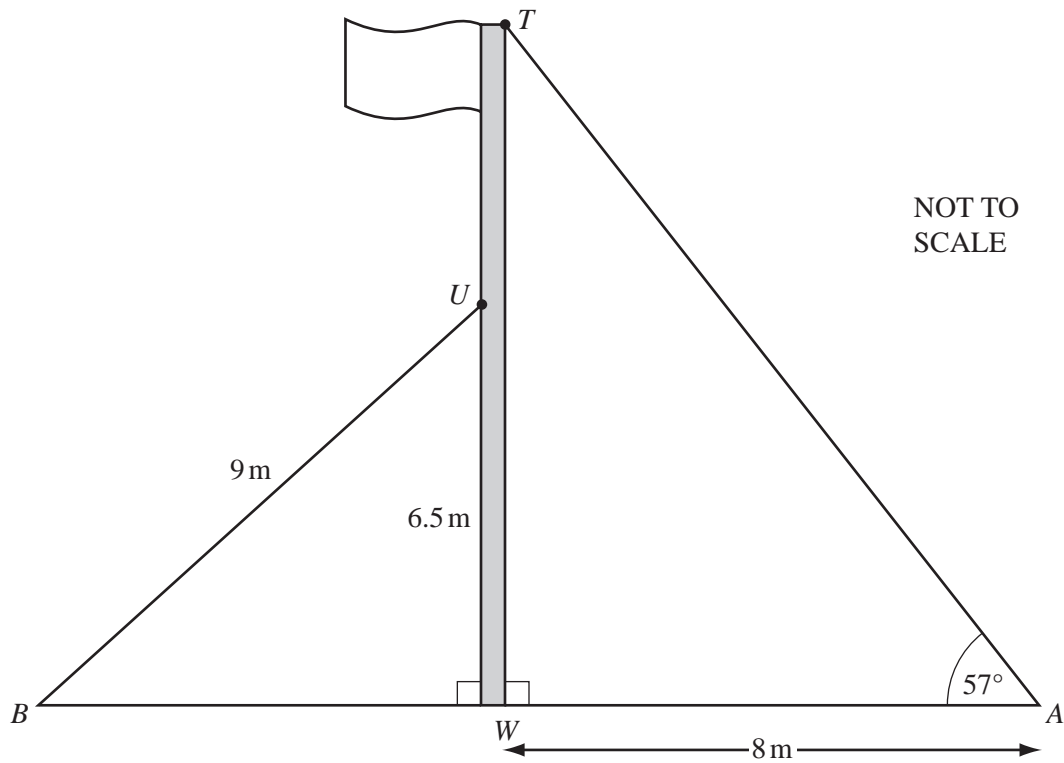

The diagram shows a vertical flagpole standing on horizontal ground. Two straight wires AT and BU are attached to the flagpole as shown.

- (a) U is 6.5 m above the ground and $BU = 9$ m.

Calculate the angle between BU and the ground.

Answer(a) [2]

- (b) The point W is vertically below the point T .
 $AW = 8$ m and angle $WAT = 57^\circ$.

Calculate TW , the height of the flagpole.

Answer(b) m [2]

For
Examiner's
Use

5

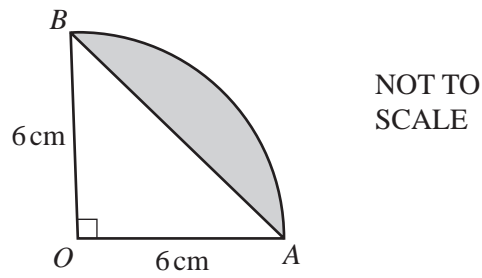

The diagram shows a sector OAB of a circle, radius 6 cm.

Angle $AOB = 90^\circ$.

(a) Calculate

(i) the area of triangle OAB ,

Answer(a)(i) cm^2 [2]

(ii) the area of the sector OAB ,

Answer(a)(ii) cm^2 [2]

(iii) the area of the region shaded in the diagram.

Answer(a)(iii) cm^2 [1]

(b) Calculate

(i) the length of AB ,

Answer(b)(i) cm [2]

(ii) the perimeter of the region shaded in the diagram.

Answer(b)(ii) cm [3]

6

For
Examiner's
Use

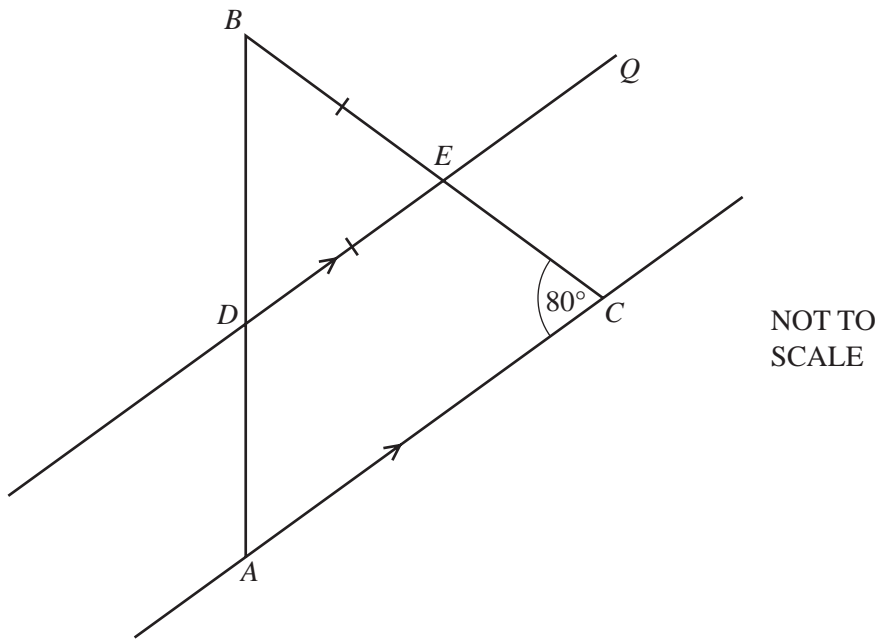

In the diagram, DEQ is parallel to AC .
 $DE = BE$ and angle $ACB = 80^\circ$.

(a) (i) Write down the size of angle CEQ .

Answer(a)(i) Angle $CEQ = \dots\dots\dots$ [1]

(ii) Give a reason for your answer.

$\dots\dots\dots$ [1]

(b) Find the size of

(i) angle BEQ ,

Answer(b)(i) Angle $BEQ = \dots\dots\dots$ [1]

(ii) angle DBE ,

Answer(b)(ii) Angle $DBE = \dots\dots\dots$ [1]

(iii) angle BAC .

Answer(b)(iii) Angle $BAC = \dots\dots\dots$ [1]

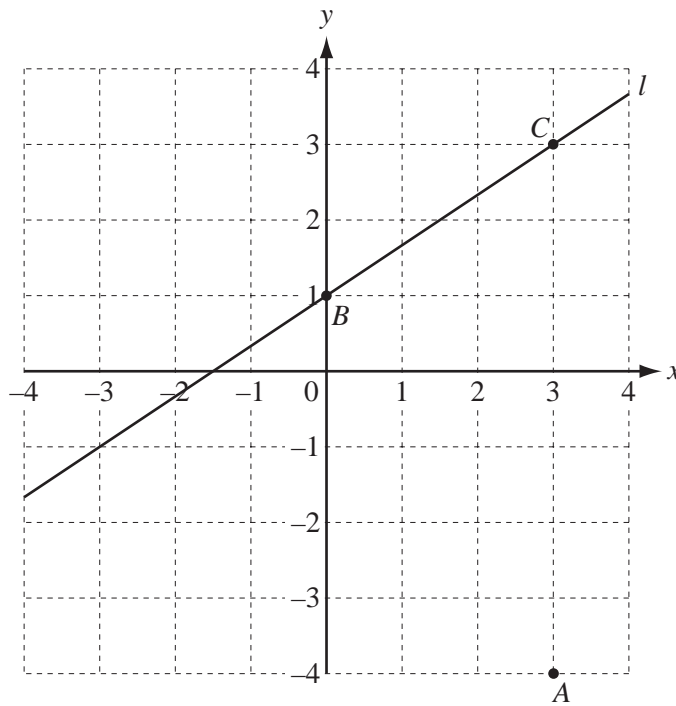

(a) Write down the co-ordinates of the point *A*.

Answer(a) (..... ,) [1]

(b) Write the vector \vec{AB} in component form.

Answer(b) $\left(\begin{array}{c} \\ \end{array} \right)$ [1]

(c) The line *l* passes through *B* and *C*.

(i) Find the gradient of the line *l*.

Answer(c)(i) [2]

(ii) Find the equation of the line *l*.

Answer(c)(ii) [2]

8

For
Examiner's
Use

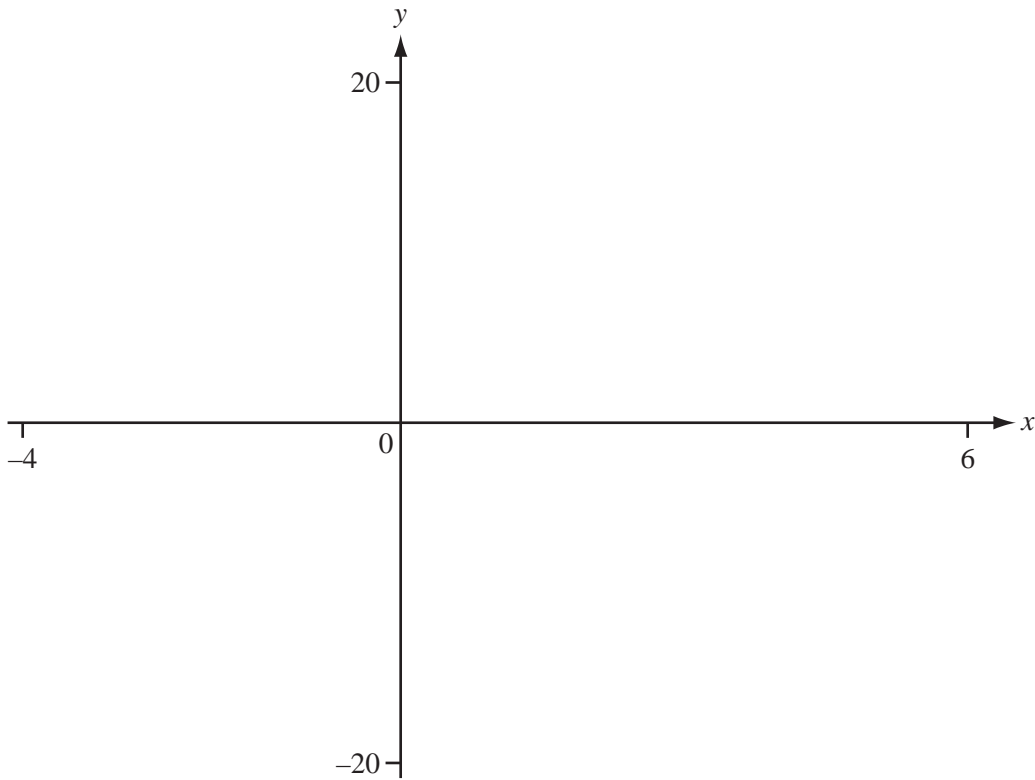

(a) On the axes, sketch the graph of $y = \frac{10}{x - 3}$, between $x = -4$ and $x = 6$.
(The graph has two separate parts.) [3]

(b) The graph has two asymptotes.

(i) On the axes, sketch the asymptote which is parallel to the y -axis. [1]

(ii) Write down the equation of this asymptote.

Answer(b)(ii) [1]

(c) (i) On the axes, sketch the graph of $y = \frac{x^2}{2}$. [1]

(ii) Solve the equation $\frac{10}{x - 3} = \frac{x^2}{2}$.

Answer(c)(ii) $x =$ [1]

9

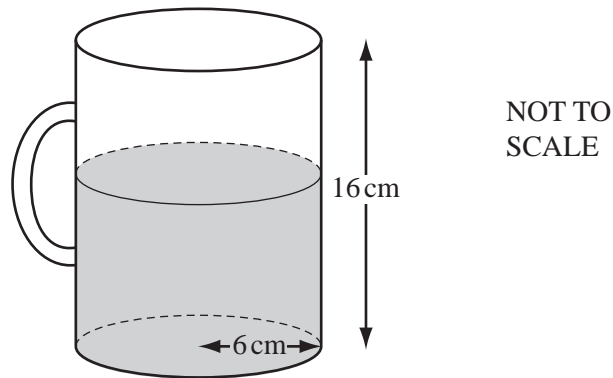

The diagram shows a glass jug.
The jug is a cylinder of radius 6 cm and height 16 cm.

(a) Calculate the volume of the jug

(i) in cm^3 ,

Answer(a)(i) cm^3 [2]

(ii) in litres.

Answer(a)(ii) litres [1]

(b) There are 1500 cm^3 of water in the jug.

(i) Calculate the height of the water in the jug.

Answer(b)(i) cm [2]

(ii) How many 25 cl glasses can be filled from the 1500 cm^3 of water in the jug?

Answer(b)(ii) [2]

For
Examiner's
Use

10 (a)

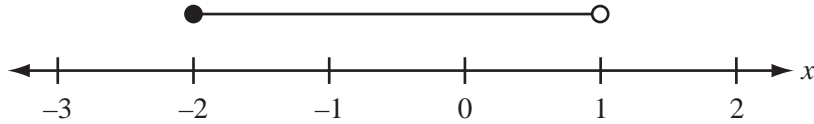

Write down the inequality shown in the diagram.

Answer(a) [2]

(b) Solve the simultaneous equations.
Show your method.

$$\begin{aligned} 2x + y &= 1 \\ y &= 2x - 5 \end{aligned}$$

Answer(b) $x =$
 $y =$ [3]

(c) The perimeter, P , of a semicircle of radius r , is given by the following formula.

$$P = \pi r + 2r$$

(i) Factorise $\pi r + 2r$.

Answer(c)(i) [1]

(ii) Rearrange the formula $P = \pi r + 2r$ to give r in terms of π and P .

Answer(c)(ii) $r =$ [1]

- 12 100 students estimate the length, l , of a piece of string.

The results are shown in the table.

Length (l cm)	$0 \leq l < 30$	$30 \leq l < 40$	$40 \leq l < 50$	$50 \leq l < 60$	$60 \leq l < 70$	$70 \leq l < 100$
Frequency	3	12	30	35	18	2

- (a) Using the mid-values of the class intervals, calculate an estimate of the mean.

Answer(a) cm [2]

- (b) (i) Complete the cumulative frequency table.

Length (l cm)	$l < 30$	$l < 40$	$l < 50$	$l < 60$	$l < 70$	$l < 100$
Cumulative frequency	3	15			98	100

[2]

- (ii) On the grid opposite, complete the cumulative frequency curve.

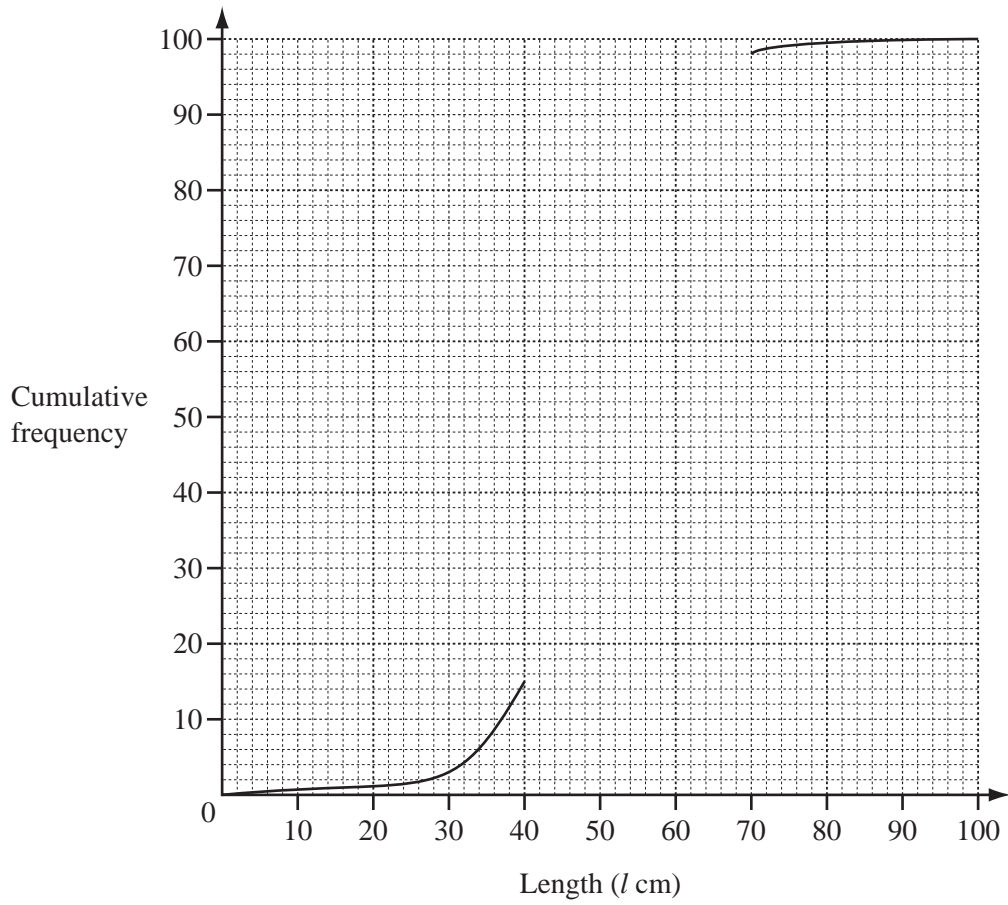

[2]

(iii) Use your cumulative frequency curve to find the inter-quartile range.

Answer(b)(iii) cm [2]

BLANK PAGE

BLANK PAGE

Permission to reproduce items where third-party owned material protected by copyright is included has been sought and cleared where possible. Every reasonable effort has been made by the publisher (UCLES) to trace copyright holders, but if any items requiring clearance have unwittingly been included, the publisher will be pleased to make amends at the earliest possible opportunity.

University of Cambridge International Examinations is part of the Cambridge Assessment Group. Cambridge Assessment is the brand name of University of Cambridge Local Examinations Syndicate (UCLES), which is itself a department of the University of Cambridge.