



Cambridge IGCSE™

CANDIDATE
NAME

--

CENTRE
NUMBER

--	--	--	--	--

CANDIDATE
NUMBER

--	--	--	--



CAMBRIDGE INTERNATIONAL MATHEMATICS

0607/42

Paper 4 (Extended)

May/June 2020

2 hours 15 minutes

You must answer on the question paper.

You will need: Geometrical instruments

INSTRUCTIONS

- Answer **all** questions.
- Use a black or dark blue pen. You may use an HB pencil for any diagrams or graphs.
- Write your name, centre number and candidate number in the boxes at the top of the page.
- Write your answer to each question in the space provided.
- Do **not** use an erasable pen or correction fluid.
- Do **not** write on any bar codes.
- You should use a graphic display calculator where appropriate.
- You may use tracing paper.
- You must show all necessary working clearly and you will be given marks for correct methods, including sketches, even if your answer is incorrect.
- Give non-exact numerical answers correct to 3 significant figures, or 1 decimal place for angles in degrees, unless a different level of accuracy is specified in the question.
- For π , use your calculator value.

INFORMATION

- The total mark for this paper is 120.
- The number of marks for each question or part question is shown in brackets [].

This document has **20** pages. Blank pages are indicated.

Formula List

For the equation $ax^2 + bx + c = 0$ $x = \frac{-b \pm \sqrt{b^2 - 4ac}}{2a}$

Curved surface area, A , of cylinder of radius r , height h . $A = 2\pi rh$

Curved surface area, A , of cone of radius r , sloping edge l . $A = \pi rl$

Curved surface area, A , of sphere of radius r . $A = 4\pi r^2$

Volume, V , of pyramid, base area A , height h . $V = \frac{1}{3}Ah$

Volume, V , of cylinder of radius r , height h . $V = \pi r^2 h$

Volume, V , of cone of radius r , height h . $V = \frac{1}{3}\pi r^2 h$

Volume, V , of sphere of radius r . $V = \frac{4}{3}\pi r^3$

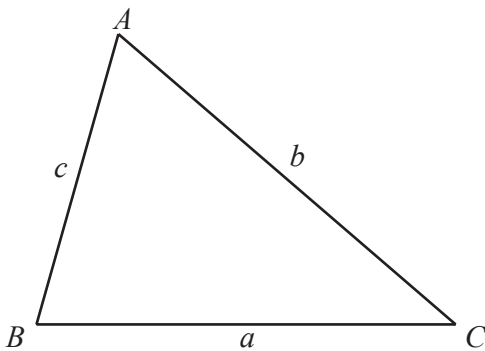

$$\frac{a}{\sin A} = \frac{b}{\sin B} = \frac{c}{\sin C}$$

$$a^2 = b^2 + c^2 - 2bc \cos A$$

$$\text{Area} = \frac{1}{2}bc \sin A$$

Answer **all** the questions.

- 1** A class of 40 students complete a science test.
The table shows the marks of the 40 students.

Mark	0	1	2	3	4	5	6	7	8	9	10
Number of students	1	1	2	5	5	5	6	3	9	2	1

- (a) Write down the mode.

..... [1]

- (b) Work out the range.

..... [1]

- (c) Find the median.

..... [1]

- (d) Find the interquartile range.

..... [2]

- (e) Calculate the mean.

..... [2]

- (f) Two of the students are chosen at random.

Find the probability that the difference in their marks is 8.

..... [3]

2 (a)

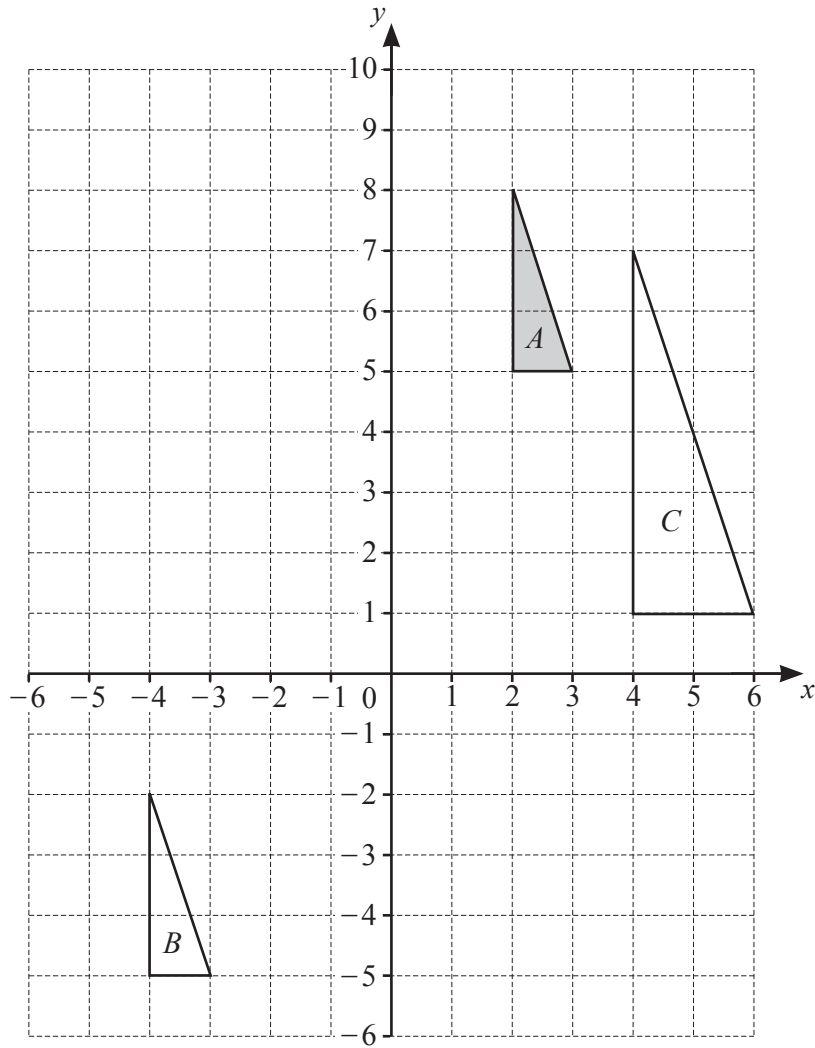

(i) Describe fully the **single** transformation that maps triangle *A* onto triangle *B*.

.....
 [2]

(ii) Describe fully the **single** transformation that maps triangle *A* onto triangle *C*.

.....
 [3]

(b) You may use the grid to help you in answering this question.

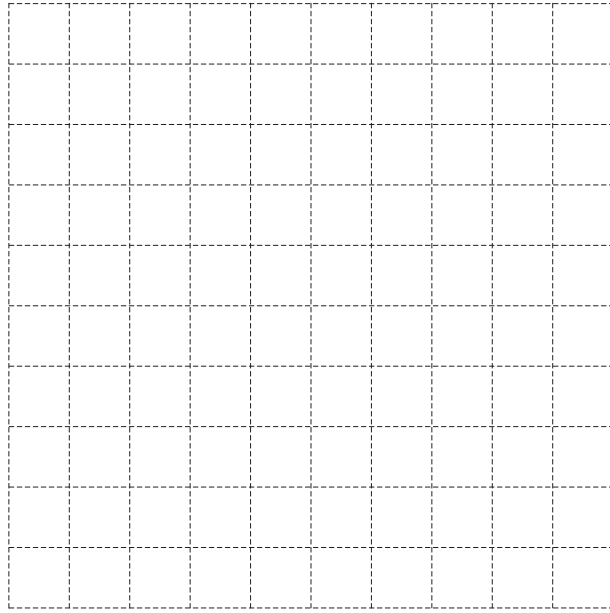

The transformation P is a rotation of 90° clockwise about the origin.
The transformation Q is a reflection in the line $y = -x$.

(i) Find the image of the point $(5, -2)$ under the transformation P.

(.....,) [1]

(ii) Find the image of the point $(5, -2)$ under the transformation Q.

(.....,) [1]

(iii) Describe fully the **single** transformation equivalent to P followed by Q.

.....
..... [2]

(iv) Describe fully the **single** transformation equivalent to Q followed by P.

.....
..... [2]

- 3 Petra is a singer. She wants to estimate how much to spend on advertising. The table shows the amount spent on advertising, $\$x$, and the number of tickets sold, y , for 10 performances.

Amount spent ($\$x$)	80	60	50	120	90	40	100	110	70	150
Number of tickets sold (y)	100	90	60	150	100	75	120	120	100	150

- (a) (i) Complete the scatter diagram. The first six points have been plotted for you.

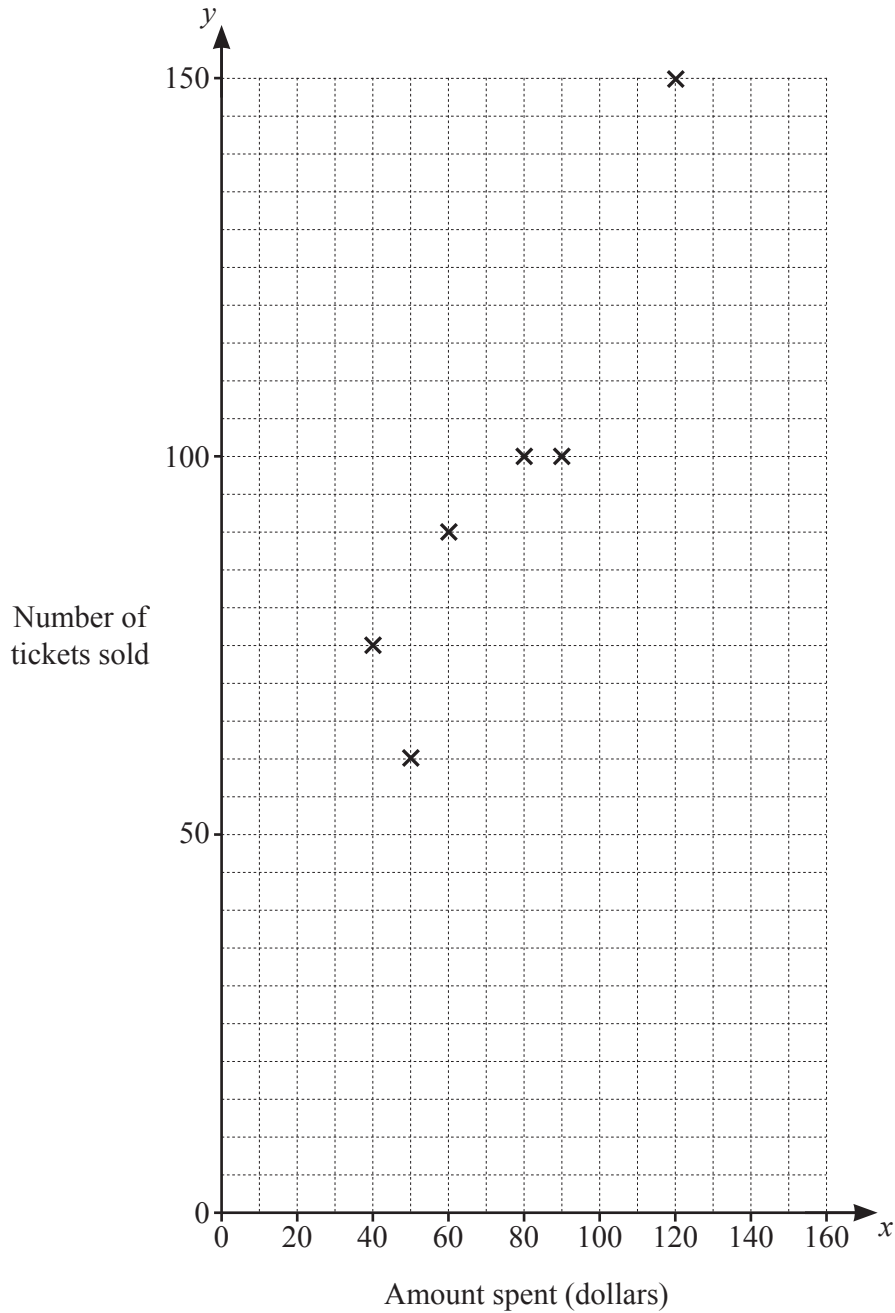

[2]

- (ii) What type of correlation is shown by the scatter diagram?

..... [1]

(b) Find the mean amount of money spent on advertising.

\$ [1]

(c) (i) Find the equation of the regression line for y in terms of x .

$y =$ [2]

(ii) Use your regression line to estimate the number of tickets sold when Petra spends \$130 on advertising.

..... [1]

(iii) Explain why Petra should not rely on this regression line to estimate the number of tickets she will sell if she spends \$500 on advertising.

.....

..... [1]

- 4 A piece of metal is in the shape of a cuboid.
 The cuboid has length 18 cm, width 12 cm and height 12 cm.
 A cylinder is removed from the cuboid.
 The cylinder has length 18 cm and radius 4 cm.

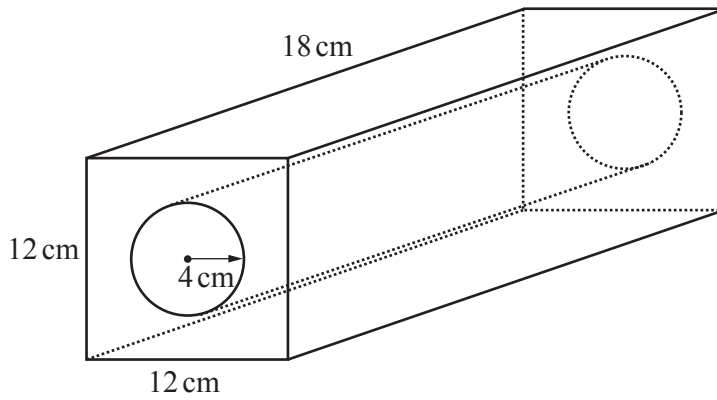

NOT TO
SCALE

- (a) (i) Find the volume of the metal remaining after the cylinder has been removed.

..... cm^3 [3]

- (ii) Write your answer to **part (i)** in standard form.

..... cm^3 [1]

(b) Find the total surface area of the metal remaining after the cylinder has been removed.

..... cm^2 [4]

(c) The **cylinder removed** is melted and formed into 16 identical spheres.

(i) Calculate the volume of **one** sphere.

..... cm^3 [1]

(ii) Calculate the radius of one sphere.

..... cm [2]

- 5 Fifty students, 25 boys and 25 girls, were asked which sport they prefer. The results are shown in the table.

	Athletics	Football	Swimming	Tennis
Boy	4	9	2	10
Girl	3	3	12	7

- (a) A student is selected at random.

Calculate the probability that the student chosen is

- (i) a girl who prefers swimming,

..... [1]

- (ii) a boy who **does not** prefer football,

..... [1]

- (iii) a student who prefers athletics.

..... [1]

- (b) Two of the girls are chosen at random.

Calculate the probability they both prefer tennis.

..... [2]

(c) Two of the students who prefer athletics are chosen at random.

Calculate the probability that one is a boy and one is a girl.

..... [3]

(d) Three of the 50 students are chosen at random.

Calculate the probability that one is a boy and two are girls and they all prefer swimming.

..... [4]

- 6 Herman bought a motorbike on 1 January 2014.
By 1 January 2015 the value of the motorbike had reduced by 16%.
By 1 January 2016 the value of the motorbike had reduced by 12% of the value on 1 January 2015.
The value of the motorbike on 1 January 2016 was \$7392.

(a) Find how much Herman paid for the motorbike.

\$ [3]

(b) From 2016, the value of the motorbike reduced by 8% each year.

Calculate the number of complete years it will take for the value of the motorbike to decrease from \$7392 to \$5000.

..... [4]

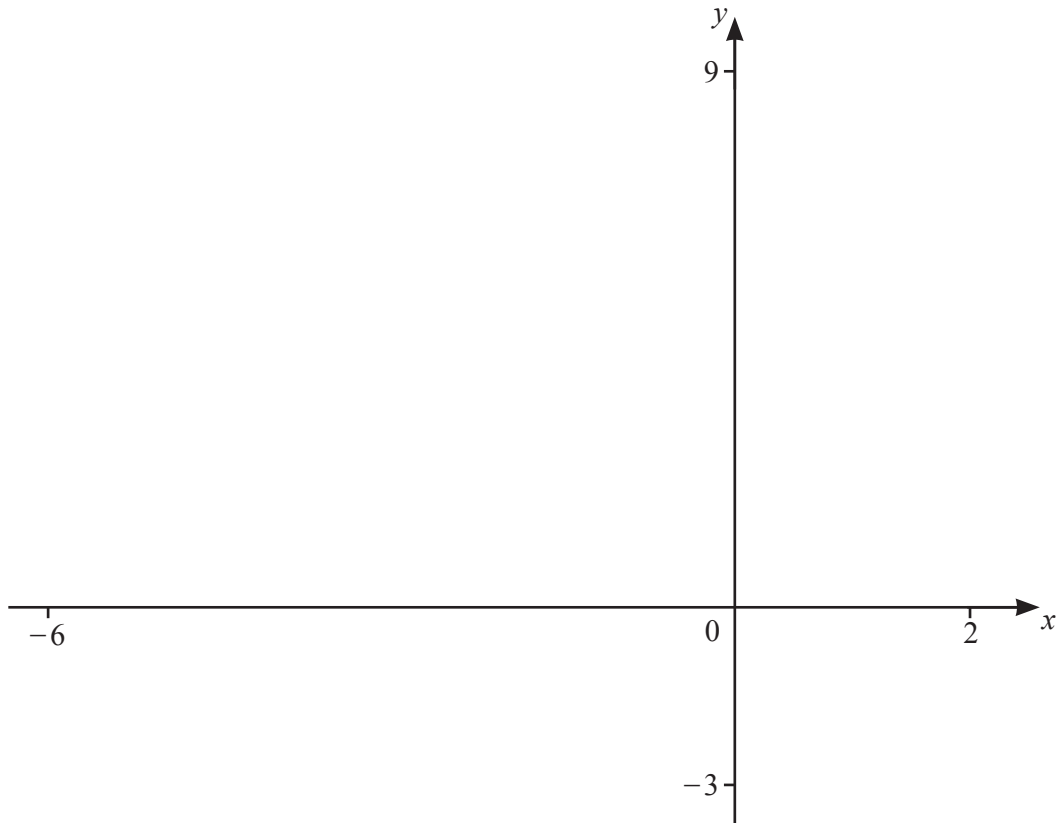

(a) $f(x) = 2 + \frac{1}{x+2}$

(i) On the diagram, sketch the graph of $y = f(x)$ for values of x between -6 and 2 . [2]

(ii) Write down the coordinates of the points where the graph crosses the axes.
 (.....,) and (.....,) [2]

(iii) Write down the equations of the asymptotes of the graph.
, [2]

(b) $g(x) = (x+4)^2$

On the diagram, sketch the graph of $y = g(x)$ for $-6 \leq x \leq -1$. [2]

(c) Solve the equation.

$f(x) = g(x)$
 [3]

(d) Solve the inequality.

$f(x) \geq g(x)$
 [2]

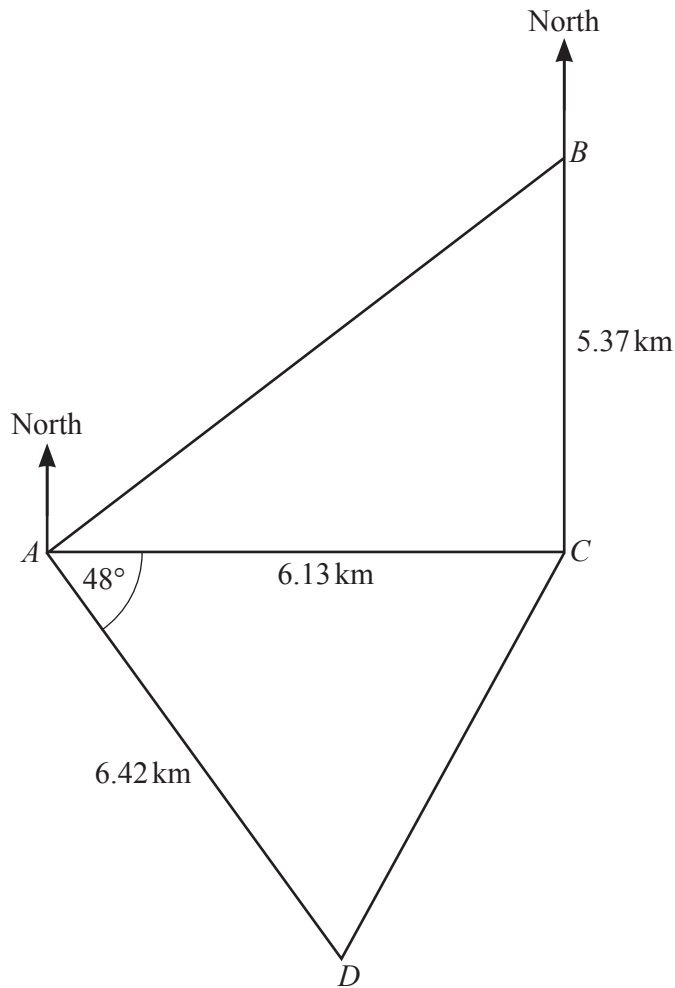

NOT TO SCALE

The diagram shows four points A , B , C and D on horizontal ground.

B is due North of C and C is due East of A .

(a) Find the bearing of

(i) D from A ,

..... [1]

(ii) A from D .

..... [1]

(b) Calculate angle ABC .

Angle $ABC =$ [2]

(c) Calculate the area of quadrilateral $ABCD$.

..... km^2 [3]

(d) Calculate CD .

$CD =$ km [3]

(e) Angle ACD is acute.

Find the bearing of D from C .

..... [4]

9 $f(x) = 4 - 3x$ $g(x) = \frac{1}{x-1}, x \neq 1$ $h(x) = x^2$

(a) Find

(i) $f(2)$,

..... [1]

(ii) $f(g(4))$.

..... [2]

(b) Find $g(g(-1))$.

..... [2]

(c) Solve.

$h(f(x)) = 9$

$x = \dots\dots\dots$ or $x = \dots\dots\dots$ [3]

(d) Find $(f(x))^2 - 1$ in terms of x .

Give your answer in the form $k(ax + b)(cx + d)$ where a, b, c, d and k are integers.

..... [3]

10

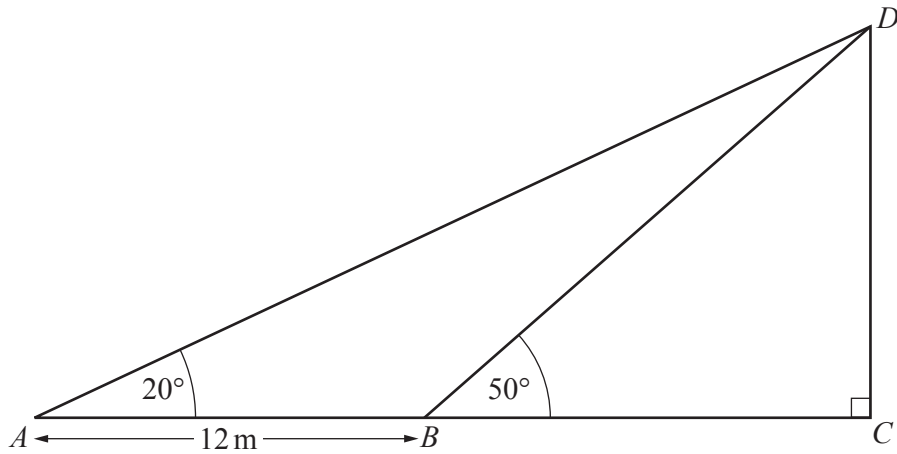
NOT TO
SCALE

The diagram shows a vertical pole CD .
 ABC is a straight line on level ground.

Find DC .

$DC = \dots\dots\dots$ m [6]

11 (a) Solve the equations.

(i) $5 + 2x = 1$

$x = \dots\dots\dots$ [2]

(ii) $6 - \frac{10}{x} = 1$

$x = \dots\dots\dots$ [2]

(iii) $3(1 - 2x) = 2 - 4(x - 7)$

$x = \dots\dots\dots$ [3]

(b) (i) Solve $6x^2 = 7 - 3x$.

Give your answers correct to 3 decimal places.
You must show all your working.

$x = \dots\dots\dots$ or $x = \dots\dots\dots$ [4]

(ii) Solve $6y^4 = 7 - 3y^2$.

Give your answers correct to 3 decimal places.

$y = \dots\dots\dots$ or $y = \dots\dots\dots$ [2]

(c) Solve $2\log x + \log 5 = 1$.

$x = \dots\dots\dots$ [4]

BLANK PAGE

Permission to reproduce items where third-party owned material protected by copyright is included has been sought and cleared where possible. Every reasonable effort has been made by the publisher (UCLES) to trace copyright holders, but if any items requiring clearance have unwittingly been included, the publisher will be pleased to make amends at the earliest possible opportunity.

To avoid the issue of disclosure of answer-related information to candidates, all copyright acknowledgements are reproduced online in the Cambridge Assessment International Education Copyright Acknowledgements Booklet. This is produced for each series of examinations and is freely available to download at www.cambridgeinternational.org after the live examination series.

Cambridge Assessment International Education is part of the Cambridge Assessment Group. Cambridge Assessment is the brand name of the University of Cambridge Local Examinations Syndicate (UCLES), which itself is a department of the University of Cambridge.