



UNIVERSITY OF CAMBRIDGE INTERNATIONAL EXAMINATIONS
International General Certificate of Secondary Education

CANDIDATE
NAME

CENTRE
NUMBER

--	--	--	--	--

CANDIDATE
NUMBER

--	--	--	--



PHYSICS

0625/32

Paper 3 Extended

October/November 2012

1 hour 15 minutes

Candidates answer on the Question Paper.

No Additional Materials are required.

READ THESE INSTRUCTIONS FIRST

Write your Centre number, candidate number and name on all the work you hand in.
Write in dark blue or black pen.
You may use a pencil for any diagrams or graphs.
Do not use staples, paper clips, highlighters, glue or correction fluid.
DO NOT WRITE IN ANY BARCODES.

Answer **all** questions.
You may lose marks if you do not show your working or if you do not use appropriate units.
Take the weight of 1 kg to be 10 N (i.e. acceleration of free fall = 10 m/s²).

At the end of the examination, fasten all your work securely together.
The number of marks is given in brackets [] at the end of each question or part question.

For Examiner's Use	
1	
2	
3	
4	
5	
6	
7	
8	
9	
10	
11	
Total	

This document consists of **19** printed pages and **1** blank page.



1 Fig. 1.1 shows a car on a roller-coaster ride.

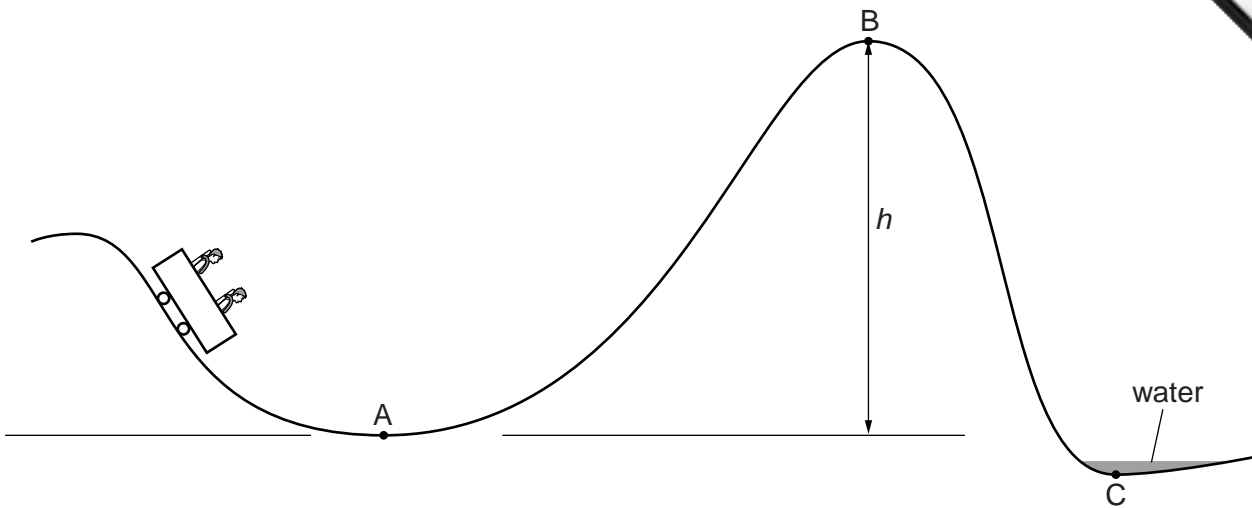

Fig. 1.1

mass of car = 600 kg

kinetic energy of car at point A = 160 kJ

(a) Calculate the speed of the car at A.

speed = [3]

(b) As the car travels from A to B, it loses 40 kJ of energy due to friction.

The car just manages to roll over the crest of the hill at B.

Calculate the height h .

height h = [2]

(c) At C, the car is slowed down by a shallow tank of water and the kinetic energy of the car is reduced to zero.

Make **three** suggestions for what happens to this kinetic energy.

1.

2.

3.

[3]

[Total: 8]

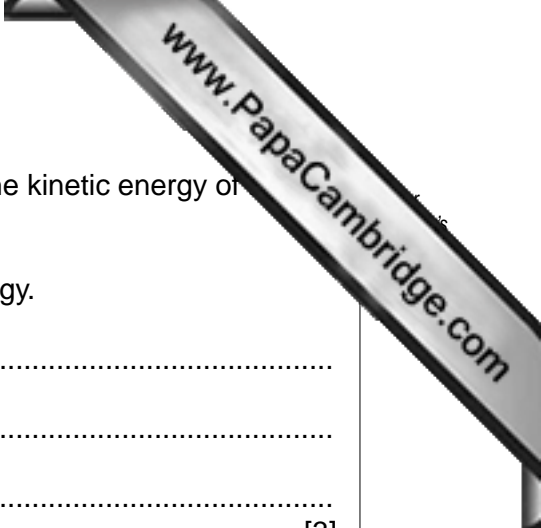

- 2 Fig. 2.1 is a head-on view of an airliner flying at constant speed in a circular horizontal path. The centre of the circle is to the left of the diagram.

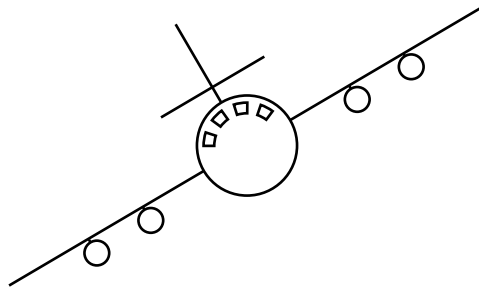

Fig. 2.1

- (a) On Fig. 2.1, draw the resultant force acting on the airliner. Explain your answer.

.....

.....

..... [3]

- (b) The weight of the airliner is 1.20×10^6 N and there is an aerodynamic lift force of 1.39×10^6 N acting at 30° to the left of the vertical.

By drawing a scale vector diagram, or otherwise, show that the resultant of these two forces is in the same direction as the resultant force you drew in (a).

(c) The speed is constant as the airliner flies in this circular path.

State and explain what is happening to the velocity.

.....

.....

.....

..... [2]

[Total: 8]

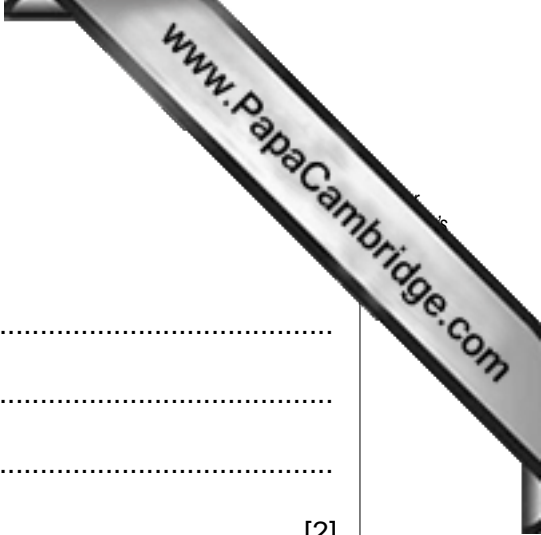

3 A thermometer uses the value of a physical property to indicate the temperature.

(a) A particular thermometer is sensitive, linear and has a wide range.

Draw a straight line from each characteristic of this thermometer to the appropriate feature.

characteristic of thermometer

sensitive

linear

wide range

feature of thermometer

reacts quickly to change of temperature

large difference between highest and lowest measurable temperatures

same change of physical property for same change of temperature

fixed points at 0°C and 100°C

large change of physical property for small change of temperature

[3]

(b) (i) In the space below, draw a diagram to show the structure of a thermocouple thermometer.

[2]



(ii) Explain why a thermocouple thermometer is particularly well suited to meas

1. high temperatures,

.....
.....

2. very rapidly changing temperatures.

.....
.....

[2]

[Total: 7]

- 4 (a) Fig. 4.1 shows some gas contained in a cylinder by a heavy piston. The piston can move up and down in the cylinder with negligible friction.

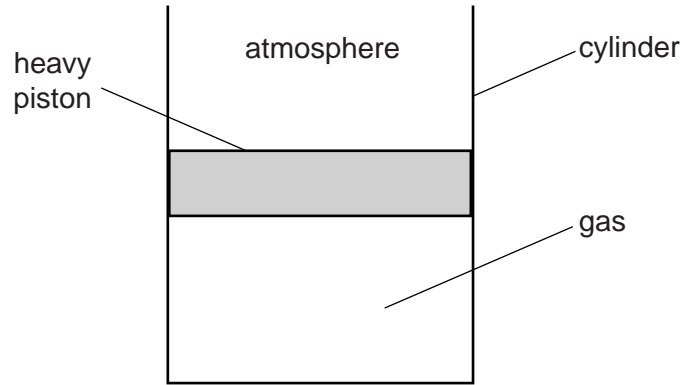

Fig. 4.1

There is a small increase in the pressure of the atmosphere above the piston.

- (i) On Fig. 4.1, draw a possible new position for the lower face of the piston. [1]
- (ii) Explain, in terms of the molecules of the gas and the molecules of the atmosphere, your answer to (a)(i).

.....

.....

.....

.....

.....

..... [3]

- (b) The pressure of the atmosphere above the piston returns to its original value, and the piston returns to its original position, as shown in Fig. 4.2.

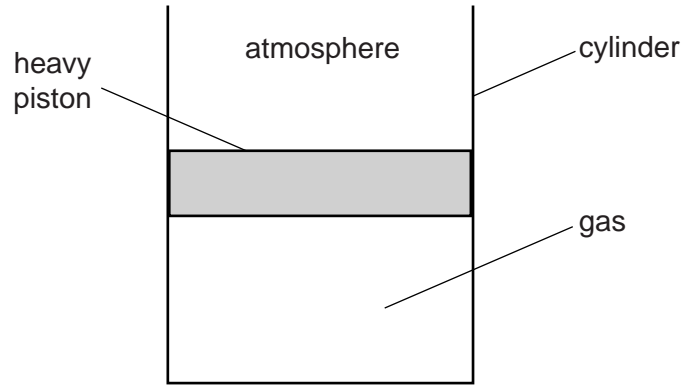

Fig. 4.2

The gas, piston and cylinder are now heated to a much higher temperature.

- (i) On Fig. 4.2, draw a possible new position for the lower face of the piston. [1]
- (ii) Explain, in terms of the molecules of the gas and the molecules of the atmosphere, your answer to (b)(i).

.....

.....

.....

.....

..... [2]

[Total: 7]

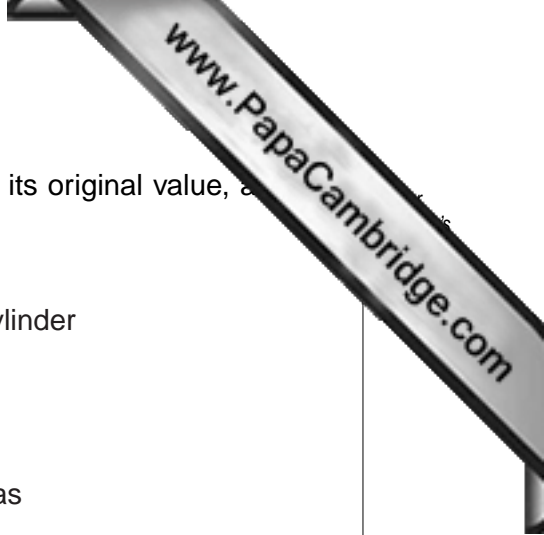

- 5 Fig. 5.1 shows a thin plastic cup containing hot coffee, which an IGCSE Physics student took from a machine.

Fig. 5.2 shows how another student, who finds an empty second cup, has placed his identical cup of coffee inside this second cup.

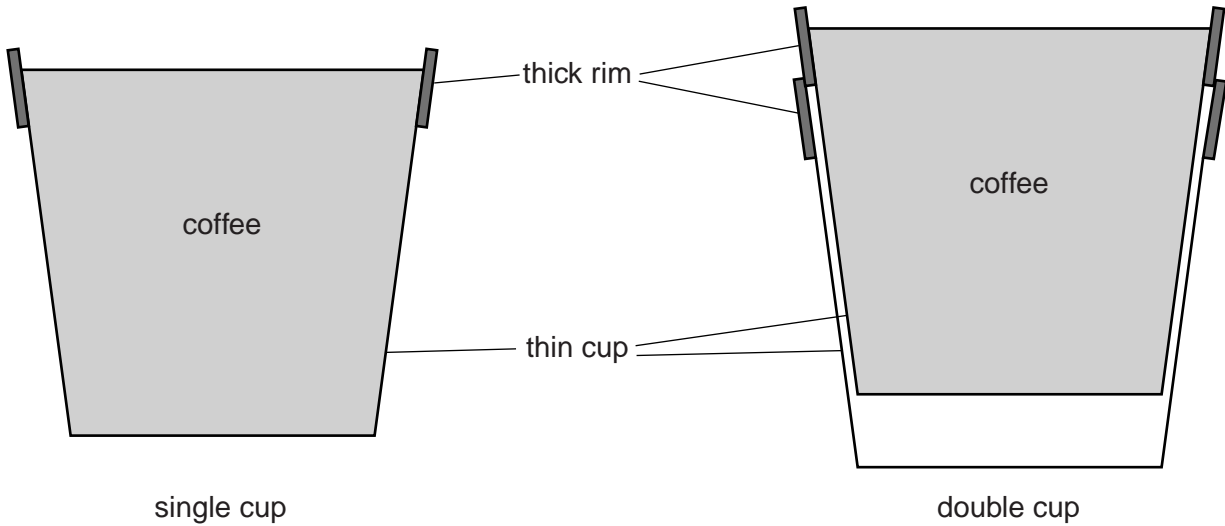

Fig. 5.1

Fig. 5.2

- (a) Suggest and explain a difference that the students will feel when holding the cups.

.....

.....

.....

..... [2]

- (b) The students discuss this experience with their teacher, who makes hot drink the subject of an experiment.

The same volume of hot water at the same temperature is placed in the single cup and in the double cup.

The temperature of the water in each cup is recorded for 10 minutes.

Fig. 5.3 shows the cooling curve for the water in the single cup.

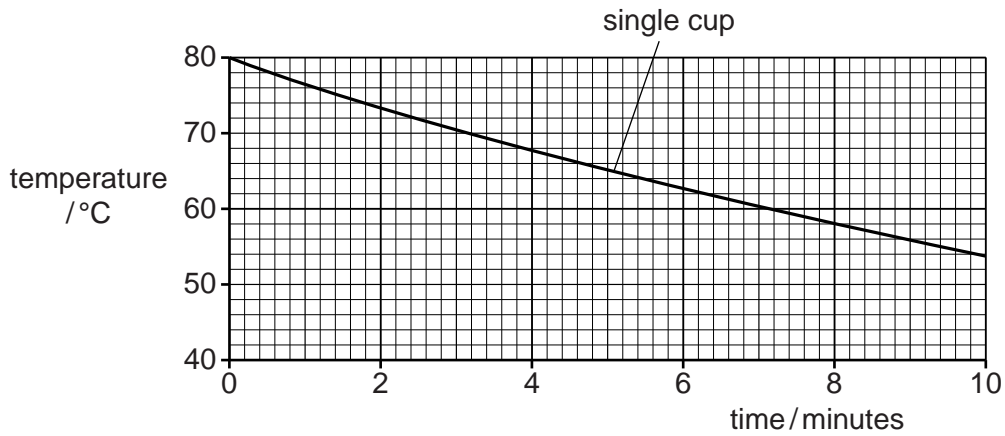

Fig. 5.3

On Fig. 5.3, sketch and label a possible cooling curve for the water in the double cup. [2]

- (c) Explain why a cup of coffee cools more slowly when a lid is placed over the cup.

.....

.....

.....

.....

..... [2]

[Total: 6]

- 6 Solar panels are positioned on the roof of the house shown in Fig. 6.1. They use energy from the Sun to provide hot water in an environmentally friendly way.

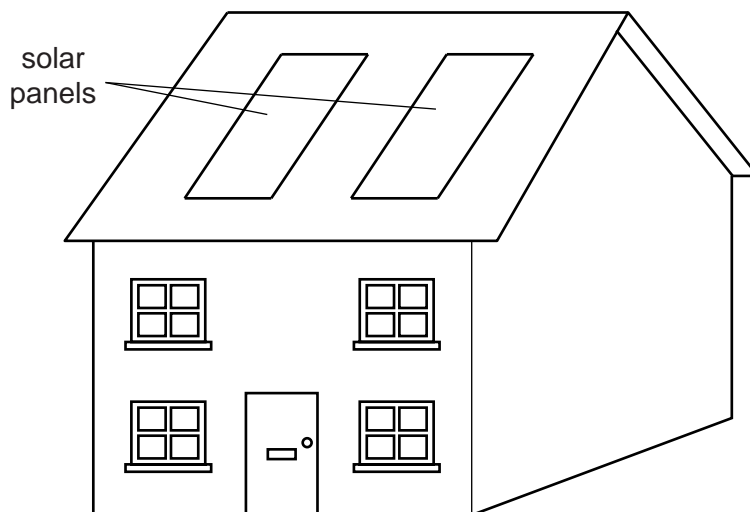

Fig. 6.1

Cold water flows to the panels at 15°C . During the day, the panels supply 3.8 kg of hot water at 65°C every hour.

- (a) Calculate the average energy that the solar panels deliver to the water in one hour. Specific heat capacity of water = $4200\text{ J}/(\text{kg}^{\circ}\text{C})$.

energy = [3]

- (b) The solar power incident on the roof during this heating period is $170\text{ W}/\text{m}^2$. The solar panels have a total area of 8.0 m^2 .

Calculate the solar energy incident on the panels in one hour.

solar energy = [2]

- (c) Calculate the efficiency of the solar panels, stating the equation you use.

efficiency = [2]

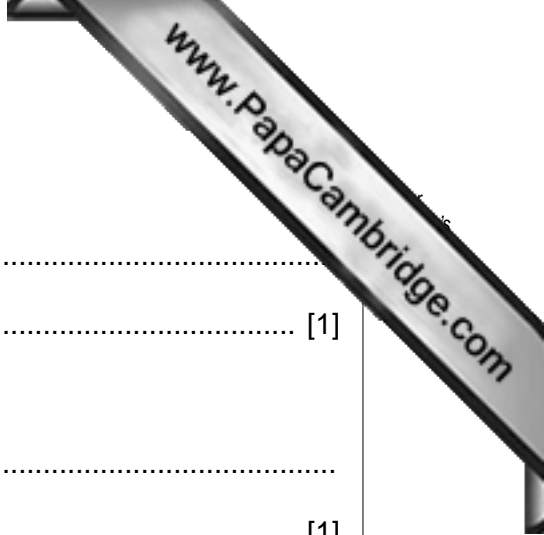

(d) Explain why solar energy is called *renewable* energy.

.....
..... [1]

(e) State one disadvantage of using solar energy.

.....
..... [1]

[Total: 9]

- 7 A small object is placed 3.0 cm from the centre of a convex lens of focal length 6.0 cm. An enlarged image is observed from the other side of the lens.

(a) On Fig. 7.1, draw a ray diagram to show the formation of this image.

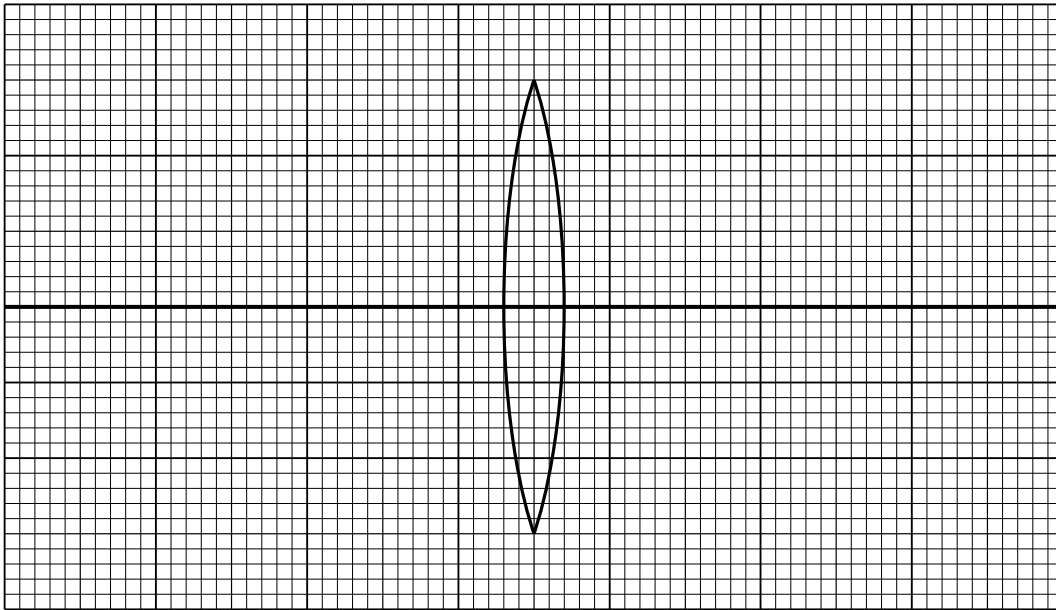

Fig. 7.1

[3]

(b) (i) State why this type of image is called *virtual*.

.....
 [1]

(ii) State the common name given to a convex lens used in this manner.

..... [1]

[Total: 5]

- 8 (a) A student rubs one side of an inflated balloon on her hair. This side of the balloon becomes positively charged. Explain this.

.....

 [2]

- (b) The charged side of the balloon is now brought close to a stream of water flowing from a pipe. The original position of the stream of water is shown in Fig. 8.1.

On Fig. 8.1, write in the boxes to indicate how each side of the stream of water is electrically charged.

Choose your answer in each case from: positive, negative or neutral.

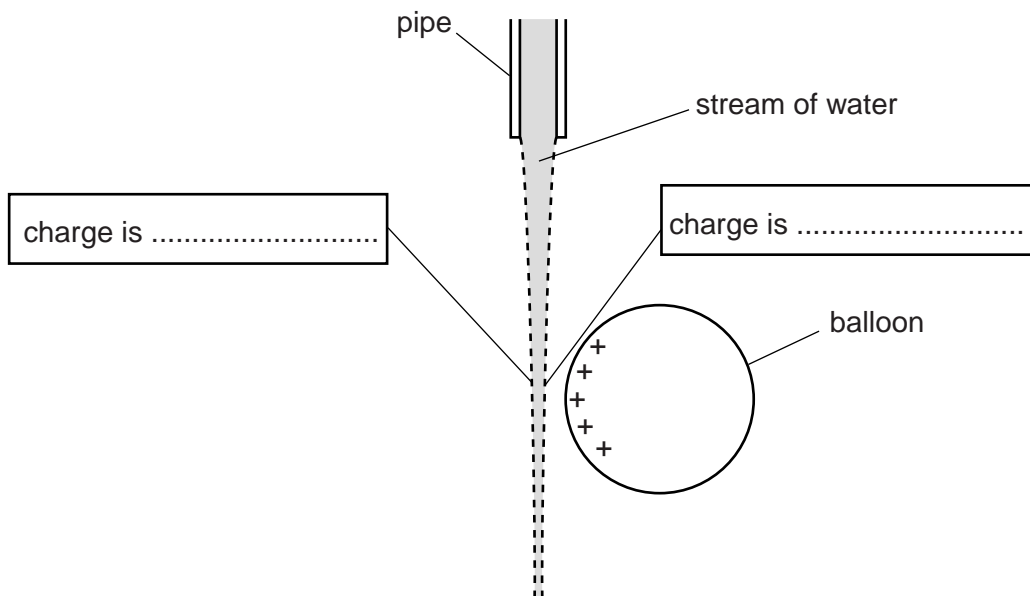

Fig. 8.1

[2]

- (c) On Fig. 8.1, draw the new position of the stream of water. Explain this new position.

.....

 [2]

- (d) Explain why rubbing one side of a metal sphere does not cause it to become charged.

.....
 [1]

- 9 Fig. 9.1 shows an experiment carried out in a vacuum to investigate the deflection of α -particles and γ -rays in a magnetic field.

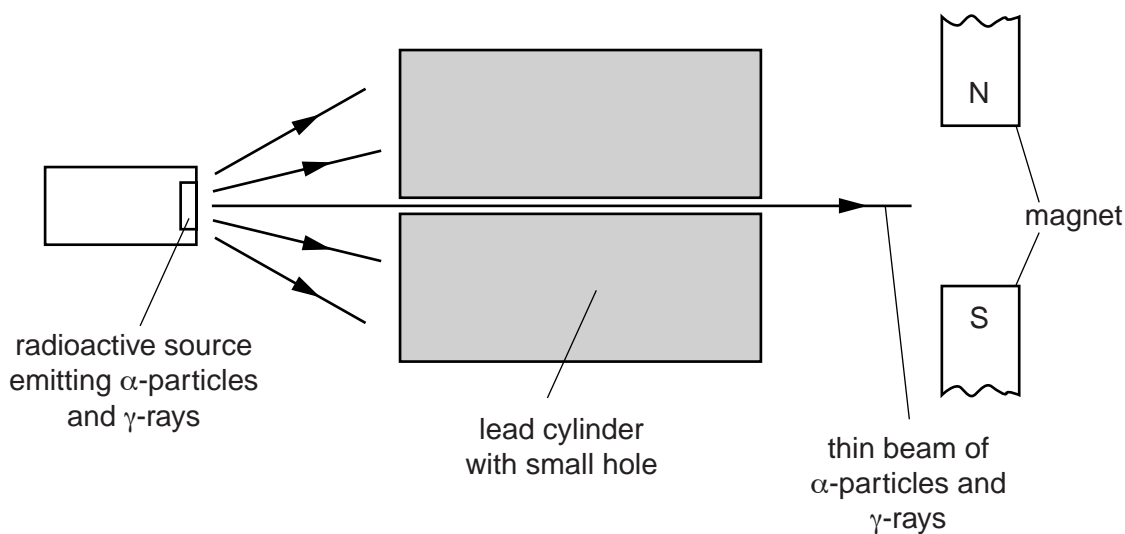

Fig. 9.1

- (a) Complete the table to describe the deflection, if any, of the α -particles and the γ -rays in the magnetic field shown. Place **one** tick in **each** column.

possible deflection	α -particles	γ -rays
no deflection		
towards N pole of magnet		
towards S pole of magnet		
out of paper		
into paper		

[3]

- (b) The experiment of Fig. 9.1 was carried out in a vacuum.

State the effect of carrying out the experiment in air.

.....

 [2]

- (c) State and explain the purpose of the lead cylinder.

.....

 [2]

- 10 (a) Determine which **one** of the following resistors, connected in parallel with a resistor, would give a total resistance of $8.0\ \Omega$. Show your working.

Available resistors: $2.0\ \Omega$, $4.0\ \Omega$, $6.0\ \Omega$, $8.0\ \Omega$, $12.0\ \Omega$, $16.0\ \Omega$, $18.0\ \Omega$, $32.0\ \Omega$

value of resistor = [3]

- (b) (i) In the space below, draw the parallel combination of resistors from (a) connected in a circuit with a 6.0V battery. The circuit should also include an ammeter to measure the current in the $24.0\ \Omega$ resistor.

[2]

- (ii) Calculate the current in each of the resistors when connected as in (b)(i). Show your working.

current in $24.0\ \Omega$ resistor =

current in the other resistor =

[3]

[Total: 8]

- 11 A student carries out an experiment with the circuit shown in Fig. 11.1. The component in the dashed box labelled X is a diode.

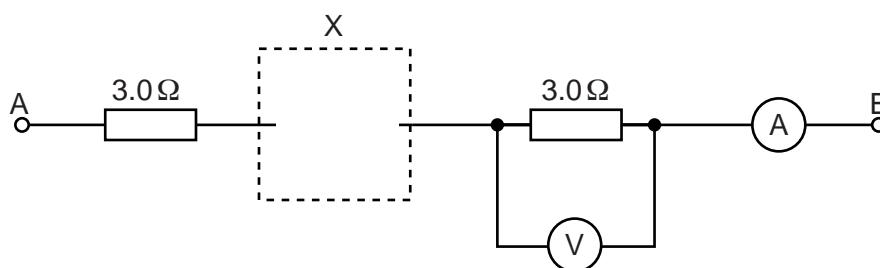

Fig. 11.1

- (a) On Fig. 11.1, draw the correct symbol for a diode, connected either way round, in the dashed box labelled X. [1]

- (b) (i) +6.0V is applied to point A, 0V to point B.

State what the student observes on the ammeter.

.....

- (ii) -6.0V is applied to point A, 0V to point B.

State what the student observes on the ammeter.

.....

[2]

- (c) The voltage shown in Fig. 11.2 is applied to the point A of the circuit in Fig. 11.1. Point B is kept at 0V.

On Fig. 11.2, draw a graph of the readings indicated by the voltmeter.

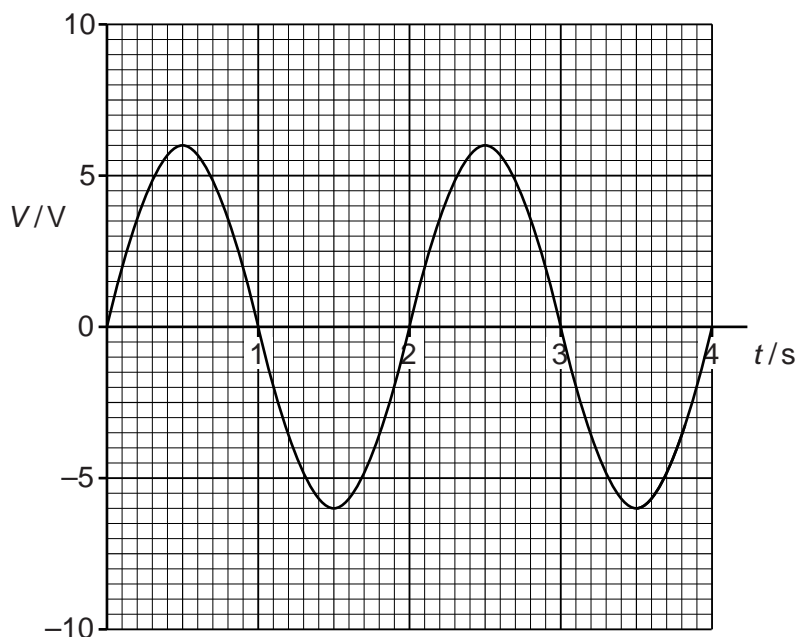

Fig. 11.2

- (d) The circuit shown in Fig. 11.3 contains two switches S_1 and S_2 and two indicator lamps L_1 and L_2 .

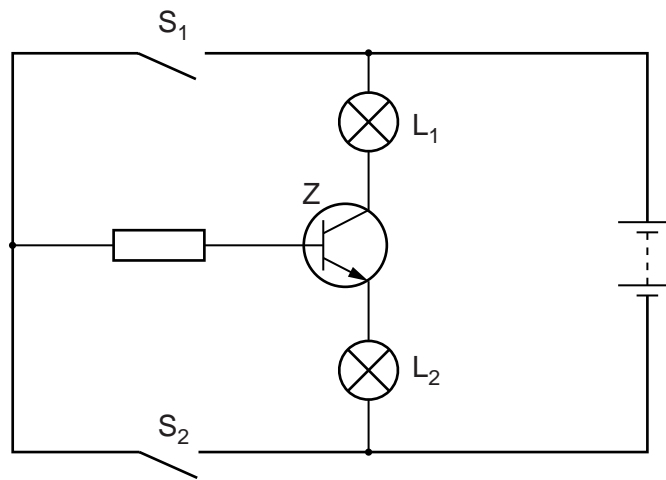

Fig. 11.3

- (i) Name component Z. [1]
- (ii) Complete the table to state whether the lamps are on or off with the switches in the positions stated.

switch S_1	switch S_2	lamp L_1	lamp L_2
open	closed		
closed	open		

[2]

[Total: 8]

