

Centre Number	Candidate Number	Name
---------------	------------------	------

UNIVERSITY OF CAMBRIDGE INTERNATIONAL EXAMINATIONS
International General Certificate of Secondary Education

COMBINED SCIENCE

0653/05

Paper 5 Practical Test

May/June 2005

1 hour 30 minutes

Candidates answer on the Question Paper.

Additional Materials: As listed in Instructions to Supervisors

READ THESE INSTRUCTIONS FIRST

Write your Centre number, candidate number and name on all the work you hand in.

Write in dark blue or black pen in the spaces provided on the Question Paper.

You may use a soft pencil for any diagrams, graphs or rough working.

Do not use staples, paper clips, highlighters, glue or correction fluid.

Answer **all** questions.

The number of marks is given in brackets [] at the end of each question or part question.

Chemistry practical notes for this paper are printed on page 8.

If you have been given a label, look at the details. If any details are incorrect or missing, please fill in your correct details in the space given at the top of this page.

Stick your personal label here, if provided.

For Examiner's Use	
1	
2	
3	
Total	

This document consists of **8** printed pages.



- 1 (a) (i) You are provided with an insect-pollinated flower.
Place the flower on its side on the white tile and draw it in the space provided.

[1]

- (ii) Label a sepal on your drawing.
What is the function of the sepal?

.....
..... [2]

- (b) Using tweezers, carefully remove the sepals, petals and stamens and place them on your white tile.

- (i) Draw one petal and one stamen in the spaces below.

petal	stamen

- (ii) Label the anther on your drawing.

[3]

- (iii) The length of the petal is the distance along it from the point where it is attached to the flower to the tip of the petal. Mark this point of attachment on your drawing with the letter **X**.

Measure the length of the petal on your diagram. mm

Now measure the length of this petal on the white tile. mm

- (iv) Use the two lengths you have measured to calculate the magnification of your drawing.

.....

.....

.....

..... [4]

- 2 You are going to investigate the relationship between the deflection of a metre rule and the mass responsible for the deflection.

Fix a metre rule to the bench using a clamp or heavy weight so that 700mm of the rule extends beyond the edge of the bench. See Fig.2.1

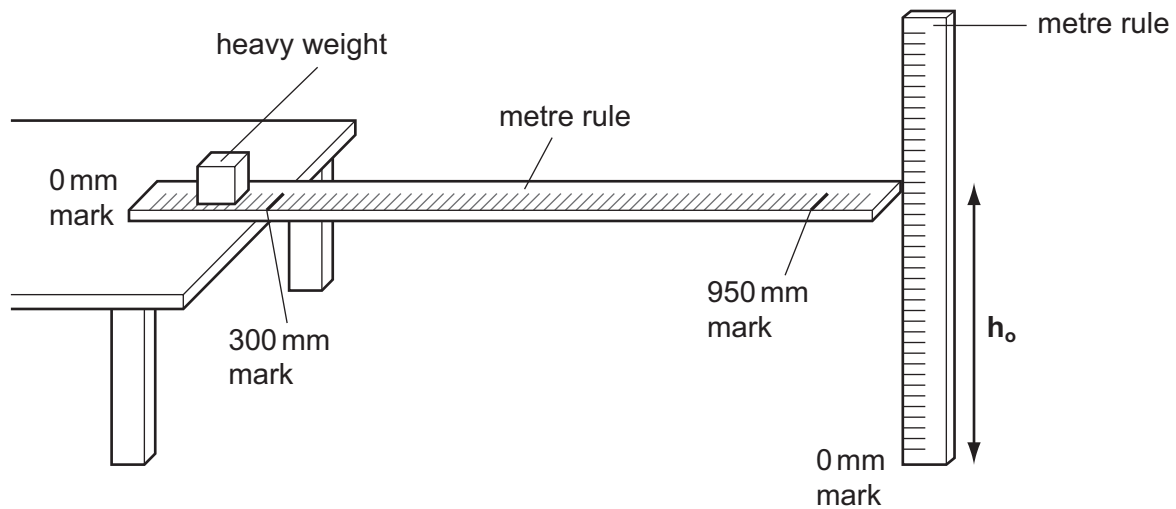

Fig.2.1

- (a) Use the second rule to measure in millimetres the height, h_0 , as shown in Fig.2.1, and record it in Fig.2.2.
- (b) Place a lump of plasticine or clay on the 950 mm mark of the rule, causing the rule to bend. Remove some plasticine, or add more, until the rule has deflected between 40 mm and 50 mm. The height, h , will now be between 40 and 50 mm less than h_0 . Record this height of the end of the rule in the space below.

height of end of rule above the floor = mm [1]

- (c) Remove the plasticine from the rule and divide it into three pieces, **approximately** equal in size.
- (d) Weigh one of these pieces to the nearest gram and record its mass in the table Fig. 2.2.

Place this weighed lump on the 950 mm mark on the rule. Measure and record the new height, h , in the table Fig. 2.2

- (e) Weigh a second piece of plasticine to the nearest gram.
- Record this mass in Fig. 2.2.
 - Add this piece of plasticine to the first. Find the height, h , when the total mass is placed on the 950 mm mark.
 - Record the height and the total mass in the table Fig. 2.2.
 - Repeat this procedure until you have four sets of readings of total mass and resultant height.

(f) Complete Fig.2.2 by calculating the deflection of the rule each time i.e. $h_0 - h$.

mass of each piece of plasticine/g	total mass/g	height h of end of rule above floor/mm	total deflection $(h_0 - h)$ /mm
0	0	$h_0 =$	0

Fig 2.2

[5]

(g) Plot a graph, of total mass of plasticine (horizontal axis) against deflection. Draw the best straight line through your points. [3]

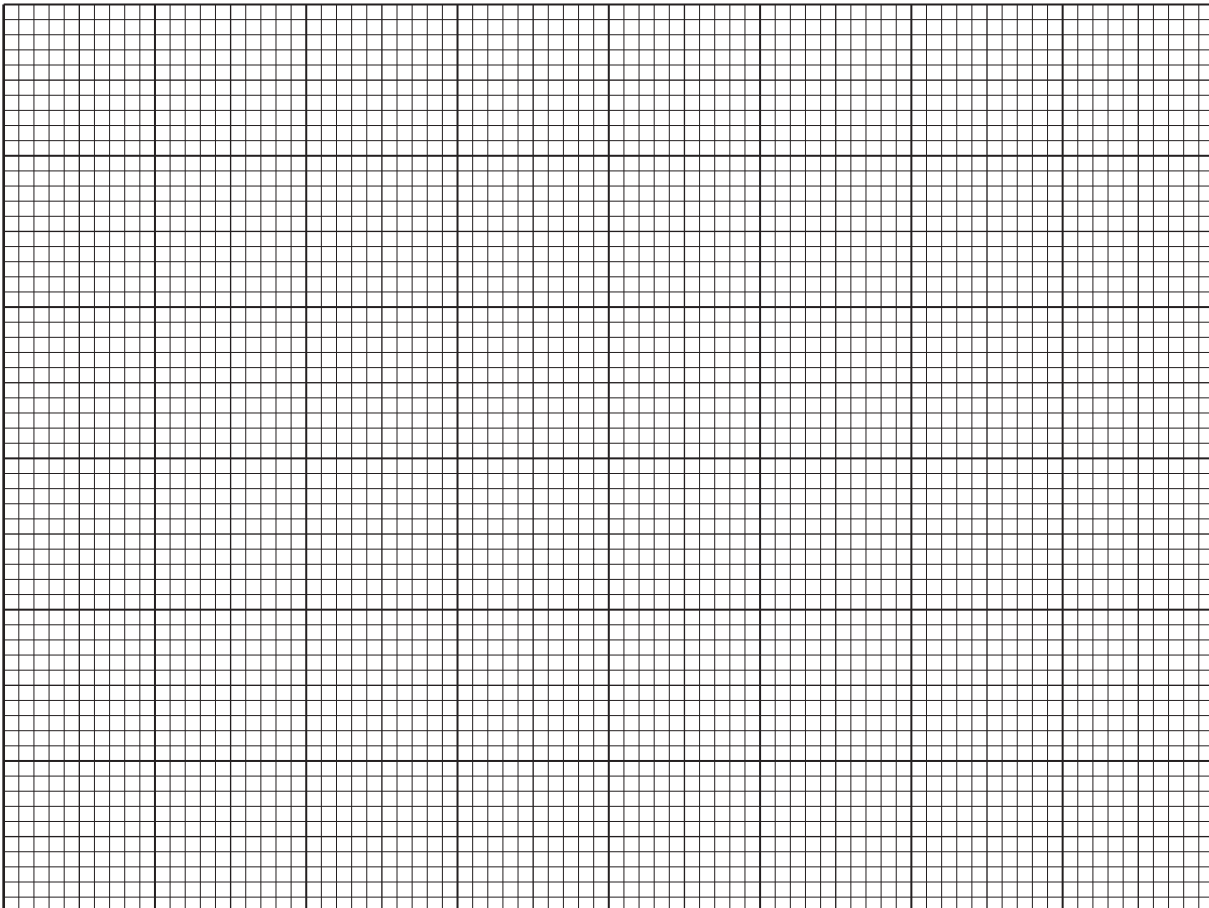

(h) What, if any, is the relationship between the mass added and the deflection?

..... [1]

- 3 You are going to measure the temperature rise when three different metals, **A**, **B** and **C**, are reacted with hydrochloric acid.

Read all the instructions before starting the experiment.

- (a) Using a measuring cylinder, add 5 cm³ of the dilute hydrochloric acid to a test-tube. Measure the temperature of the acid to the nearest 0.5 °C and record it in Fig.3.1. Add metal **A** to the acid and gently stir the mixture with the thermometer. Note the maximum temperature reached during a three-minute period and record any other observations in Fig.3.1.

Remove the thermometer and rinse it with water.

- (b) Repeat the procedure in (a), using the sample of metal **B**.
- (c) Repeat the procedure in (a) using the sample of metal **C**. You are advised to place the tube in the rack as soon as you have added the acid. Also test the gas given off with a lighted spill. Record the result of this test in the observations column of Fig.3.1.
- (d) Complete Fig. 3.1 by calculating the temperature rise in each case.

metal	temperature of acid/°C			observations
	initial	maximum	temperature rise	
A				
B				
C				

Fig. 3.1

[7]

(e) Using the results of your experiments, answer the following questions.

(i) Name the gas given off in the reaction in (c) above.

..... [1]

(ii) On the basis of the results you have obtained, place the metals in order of decreasing reactivity, i.e. the most reactive first.

..... [1]

(iii) Which observations tell you that one metal is more reactive than the other two?

.....
..... [1]

CHEMISTRY PRACTICAL NOTES

Test for anions

<i>anion</i>	<i>test</i>	<i>test result</i>
carbonate (CO_3^{2-})	add dilute acid	effervescence, carbon dioxide produced
chloride (Cl^-) [in solution]	acidify with dilute nitric acid, then add aqueous silver nitrate	white ppt.
nitrate (NO_3^-) [in solution]	add aqueous sodium hydroxide then aluminium foil; warm carefully	ammonia produced
sulphate (SO_4^{2-}) [in solution]	acidify, then add aqueous barium chloride <i>or</i> aqueous barium nitrate	white ppt.

Test for aqueous cations

<i>cation</i>	<i>effect of aqueous sodium hydroxide</i>	<i>effect of aqueous ammonia</i>
ammonium (NH_4^+)	ammonia produced on warming	–
copper(II) (Cu^{2+})	light blue ppt., insoluble in excess	light blue ppt., soluble in excess giving a dark blue solution
iron(II) (Fe^{2+})	green ppt., insoluble in excess	green ppt., insoluble in excess
iron(III) (Fe^{3+})	red-brown ppt., insoluble in excess	red-brown ppt., insoluble in excess
zinc (Zn^{2+})	white ppt., soluble in excess giving a colourless solution	white ppt., soluble in excess, giving a colourless solution

Test for gases

<i>gas</i>	<i>test and test result</i>
ammonia (NH_3)	turns damp litmus paper blue
carbon dioxide (CO_2)	turns limewater milky
chlorine (Cl_2)	bleaches damp litmus paper
hydrogen (H_2)	'pops' with a lighted splint
oxygen (O_2)	relights a glowing splint

Permission to reproduce items where third-party owned material protected by copyright is included has been sought and cleared where possible. Every reasonable effort has been made by the publisher (UCLES) to trace copyright holders, but if any items requiring clearance have unwittingly been included, the publisher will be pleased to make amends at the earliest possible opportunity.

University of Cambridge International Examinations is part of the University of Cambridge Local Examinations Syndicate (UCLES), which is itself a department of the University of Cambridge.