



UNIVERSITY OF CAMBRIDGE INTERNATIONAL EXAMINATIONS
International General Certificate of Secondary Education

CANDIDATE
NAME

CENTRE
NUMBER

--	--	--	--	--

CANDIDATE
NUMBER

--	--	--	--	--

* 7 5 4 3 0 6 6 5 1 9 *

CO-ORDINATED SCIENCES

0654/05

Paper 5 Practical Test

May/June 2007

2 hours

Candidates answer on the Question Paper.

Additional Materials: As listed in Instructions to Supervisors.

READ THESE INSTRUCTIONS FIRST

Write your Centre number, candidate number and name on all the work you hand in.

Write in dark blue or black pen.

You may use a pencil for any diagrams, graphs or rough working.

Do not use staples, paper clips, highlighters, glue or correction fluid.

DO NOT WRITE IN ANY BARCODES.

Answer **all** questions.

Chemistry practical notes for this paper are printed on page 12

At the end of the examination, fasten all your work securely together.

The number of marks is given in brackets [] at the end of each question or part question.

For Examiner's Use	
1	
2	
3	
Total	

This document consists of **9** printed pages and **3** blank pages.



BLANK PAGE

- 1 (a) (i) Place leaf **A** on the bench with its lower surface facing upwards. Make a large drawing of the leaf in the space below.

[1]

- (ii) Using the letter **T**, label on your diagram a structure involved in the transport of substances through the leaf. [1]

- (iii) Compare the colour of the upper and lower surfaces of the leaf. Record your observation and suggest an explanation for the difference.

observation

.....

.....

explanation

.....

..... [2]

- (b) Using tweezers immerse leaf **A** in the hot water provided. Observe both surfaces of the leaf. Record your observation and suggest an explanation in the spaces below.

observation

.....

.....

explanation

.....

.....

..... [3]

- (c) The following is an example of a key to identify different arthropods. You will be required to construct a key for identifying leaves.

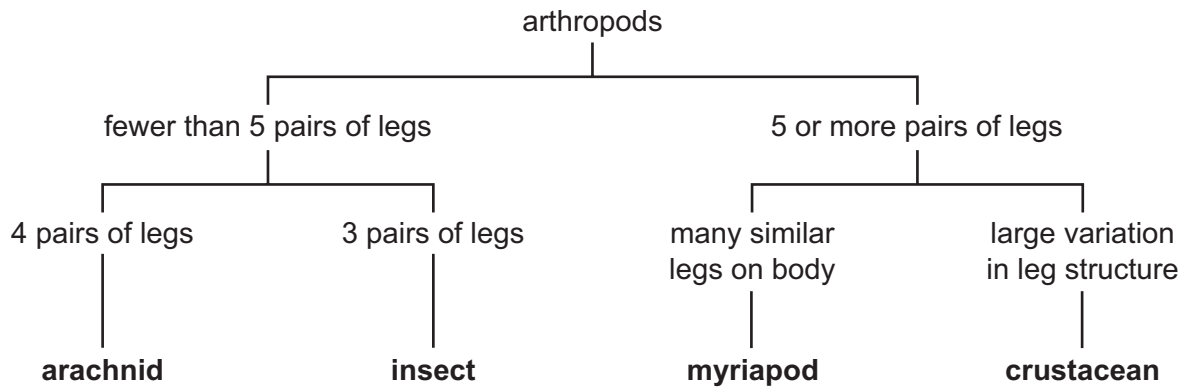

- (i) You are supplied with four leaves, labelled with their names. Make an outline drawing of each leaf in the spaces below.



name



name



name



name

[2]

- (ii) In the space provided construct a key for the leaves using visible features. Use the example of a key given above to help you. Check that the key would enable all of the leaves to be identified correctly.

[6]

- 2 You are required to find the resistances of two lamps and comment on the two values. Credit will be given for using the correct units for current, resistance and voltage in your answers.
Set up the circuit as shown in Fig. 2.1 and carry out the following experiment. You may ask for help in setting up the circuit.

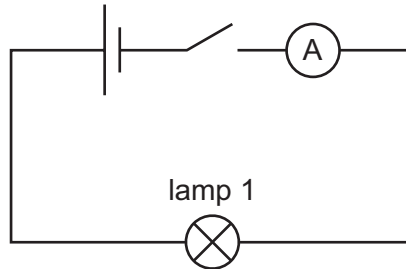

Fig. 2.1

- (a) Close the switch. Measure and record the current in the circuit. Open the switch.

current =

[2]

- (b) Connect the second lamp in series with the first as shown in Fig. 2.2

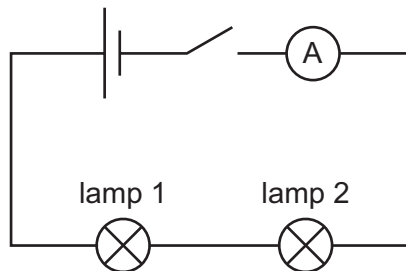

Fig. 2.2

Close the switch. Measure and record the current in the circuit with both lamps connected. Open the switch.

current =

[1]

- (c) You are now going to measure the voltage across each lamp in turn.

- (i) Connect the voltmeter across lamp 1 as shown in Fig. 2.3.

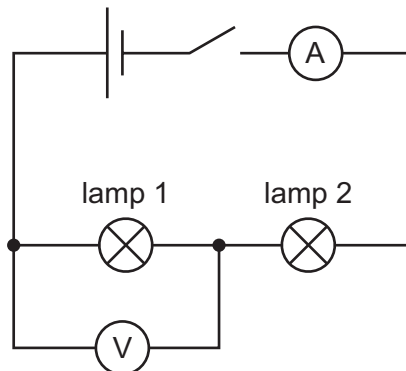

Fig. 2.3

Close the switch. Measure and record the value of the voltage. Open the switch.

voltage, V_1 , across lamp 1 = [2]

- (ii) Disconnect the voltmeter and connect it across lamp 2. Close the switch. Measure and record the value of the voltage. Open the switch.

voltage, V_2 , across lamp 2 = [2]

- (d) (i) Using the equation $R = V/I$, calculate the resistance of each lamp.

resistance, R_1 , of lamp 1 =

resistance, R_2 , of lamp 2 = [2]

- (ii) Comment on the values V_1 , V_2 , R_1 and R_2 . Within experimental error, what do these values tell you about the lamps?

.....
.....
..... [2]

- (e) (i) A student thought it was possible to increase the brightness of both the lamps by rearranging the circuit in Fig. 2.2. Draw a circuit diagram to show how this might be done.

[2]

- (ii) Explain why the lamps would be brighter using the circuit you have just drawn.

.....
.....
..... [2]

- 3 You are required to carry out the following tests on solids **X** and **Y**. Both solids are metal oxides. You will be required to name only solid **X**.

(a) Describe the appearance of both solids.

solid **X**

solid **Y** [2]

- (b) (i) Place about 5 cm³ of the hydrogen peroxide into a test-tube. Add a small quantity of solid **X**. Record your observation.

observation [1]

- (ii) Repeat test (i) using solid **Y**. This time you should test any gas given off with a glowing splint. Record your observations.

observations

test with glowing splint

name of gas given off [3]

- (iii) Which solid produced bubbles at the faster rate?

solid [1]

- (c) Place about 3 cm³ of the dilute hydrochloric acid labelled **Z** in a large test-tube. Add a little of solid **Y**. Heat carefully to boiling point. Test any gas with damp blue litmus paper. Record your observation.

observation

name of gas given off [2]

- (d) (i) Place about 5 cm³ of the dilute hydrochloric acid labelled **Z** in a large test-tube. Add a little of solid **X**. Heat carefully to boiling point. You do not need to test for any gas. Pour this mixture through a filter paper and collect the filtrate in another test-tube. Record the colour of the filtrate.

Keep your filtrate for tests in (d)(ii) and (f).

colour of filtrate [1]

- (ii) To about 2 cm³ of the filtrate, add aqueous sodium hydroxide a little at a time until there is no further change. Record your observations.

observations

..... [2]

(e) Name solid X. [1]

(f) Using the filtrate from (d)(i), carry out a test of your own to confirm the metal ion you have named in (e). Describe the test you use and the result.

.....

.....

..... [2]

CHEMISTRY PRACTICAL NOTES

Test for anions

<i>anion</i>	<i>test</i>	<i>test result</i>
carbonate (CO_3^{2-})	add dilute acid	effervescence, carbon dioxide produced
chloride (Cl^-) [in solution]	acidify with dilute nitric acid, then add aqueous silver nitrate	white ppt.
nitrate (NO_3^-) [in solution]	add aqueous sodium hydroxide then aluminium foil; warm carefully	ammonia produced
sulphate (SO_4^{2-}) [in solution]	acidify then add aqueous barium chloride <i>or</i> aqueous barium nitrate	white ppt.

Test for aqueous cations

<i>cation</i>	<i>effect of aqueous sodium hydroxide</i>	<i>effect of aqueous ammonia</i>
ammonium (NH_4^+)	ammonia produced on warming	-
copper (II) (Cu^{2+})	light blue ppt., insoluble in excess	light blue ppt., soluble in excess giving a dark blue solution
iron(II) (Fe^{2+})	green ppt., insoluble in excess	green ppt., insoluble in excess
iron(III) (Fe^{3+})	red-brown ppt., insoluble in excess	red-brown ppt., insoluble in excess
zinc (Zn^{2+})	white ppt., soluble in excess giving a colourless solution	white ppt., soluble in excess, giving a colourless solution

Test for gases

<i>gas</i>	<i>test and test results</i>
ammonia (NH_3)	turns damp litmus paper blue
carbon dioxide (CO_2)	turns limewater milky
chlorine (Cl_2)	bleaches damp litmus paper
hydrogen (H_2)	"pops" with a lighted splint
oxygen (O_2)	relights a glowing splint

Permission to reproduce items where third-party owned material protected by copyright is included has been sought and cleared where possible. Every reasonable effort has been made by the publisher (UCLES) to trace copyright holders, but if any items requiring clearance have unwittingly been included, the publisher will be pleased to make amends at the earliest possible opportunity.

University of Cambridge International Examinations is part of the University of Cambridge Local Examinations Syndicate (UCLES), which is itself a department of the University of Cambridge.