



UNIVERSITY OF CAMBRIDGE INTERNATIONAL EXAMINATIONS  
International General Certificate of Secondary Education

CANDIDATE  
NAME

CENTRE  
NUMBER

--	--	--	--	--

CANDIDATE  
NUMBER

--	--	--	--

\* 3 4 1 2 9 1 9 6 7 2 \*

**CO-ORDINATED SCIENCES**

**0654/05**

Paper 5 Practical Test

**May/June 2009**

**2 hours**

Candidates answer on the Question Paper.

Additional Materials: As listed in Instructions to Supervisors

**READ THESE INSTRUCTIONS FIRST**

Write your Centre number, candidate number and name on all the work you hand in.

Write in dark blue or black pen.

You may use a pencil for any diagrams, graphs or rough working.

Do not use staples, paper clips, highlighters, glue or correction fluid.

**DO NOT WRITE IN ANY BARCODES.**

Answer **all** questions.

Chemistry practical notes for this paper are printed on page 12.

At the end of the examination, fasten all your work securely together.

The number of marks is given in brackets [ ] at the end of each question or part question.

For Examiner's Use	
<b>1</b>	
<b>2</b>	
<b>3</b>	
<b>Total</b>	

This document consists of **10** printed pages and **2** blank pages.



- 1 Hydrogen peroxide is produced in living cells during chemical reactions. It is poisonous if it is not removed quickly. The enzyme catalase is also found in living cells. It speeds up the breakdown of hydrogen peroxide to produce oxygen gas.

For  
Examiner's  
Use

The experiment is to compare the activity of catalase in different tissues. You will use tissue **A**, which is potato, and tissue **B**. When the tissue is added to hydrogen peroxide solution, the oxygen given out is trapped in a foam as shown in Fig. 1.1. The height of foam, **h**, shows the activity of the catalase.

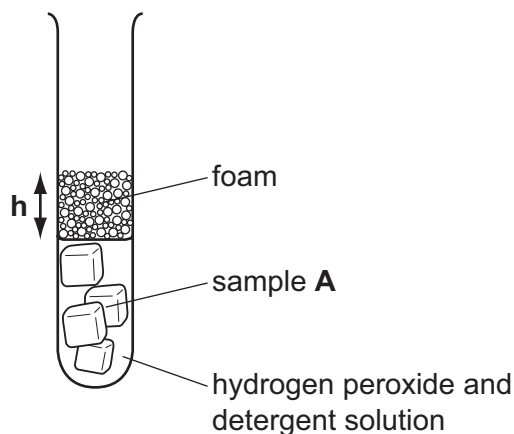

Fig. 1.1

**Take care when using hydrogen peroxide. If it gets onto your skin or in your eyes wash it off immediately with cold water.**

(a)

- Measure 10 cm<sup>3</sup> hydrogen peroxide into a large test-tube.
- Add 2 drops of detergent.
- Prepare 2 cubes of sample **A** of side 1 cm length. Cut each cube in half so that you have four equal pieces.
- Add the pieces to the test-tube and immediately start the timer.
- Measure the height, **h**, of the foam every minute for 5 minutes.
- Enter your readings in Fig. 1.2.

Repeat the complete procedure with tissue **B**.

time / mins	height of foam <b>h</b> / mm	
	tissue <b>A</b>	tissue <b>B</b>
0	0	0
1		
2		
3		
4		
5		

Fig. 1.2

[2]

The same experiment was carried out earlier with a sample of an animal's liver, tissue **C**. These results are plotted on Fig. 1.3.

(b) Using the results for tissue **A** plot the height of foam, **h**, against time on Fig. 1.3.

Draw a smooth curve through the points and label the line **A**.

On the same grid plot the results for tissue **B** and label the curve.

[4]

For  
Examiner's  
Use

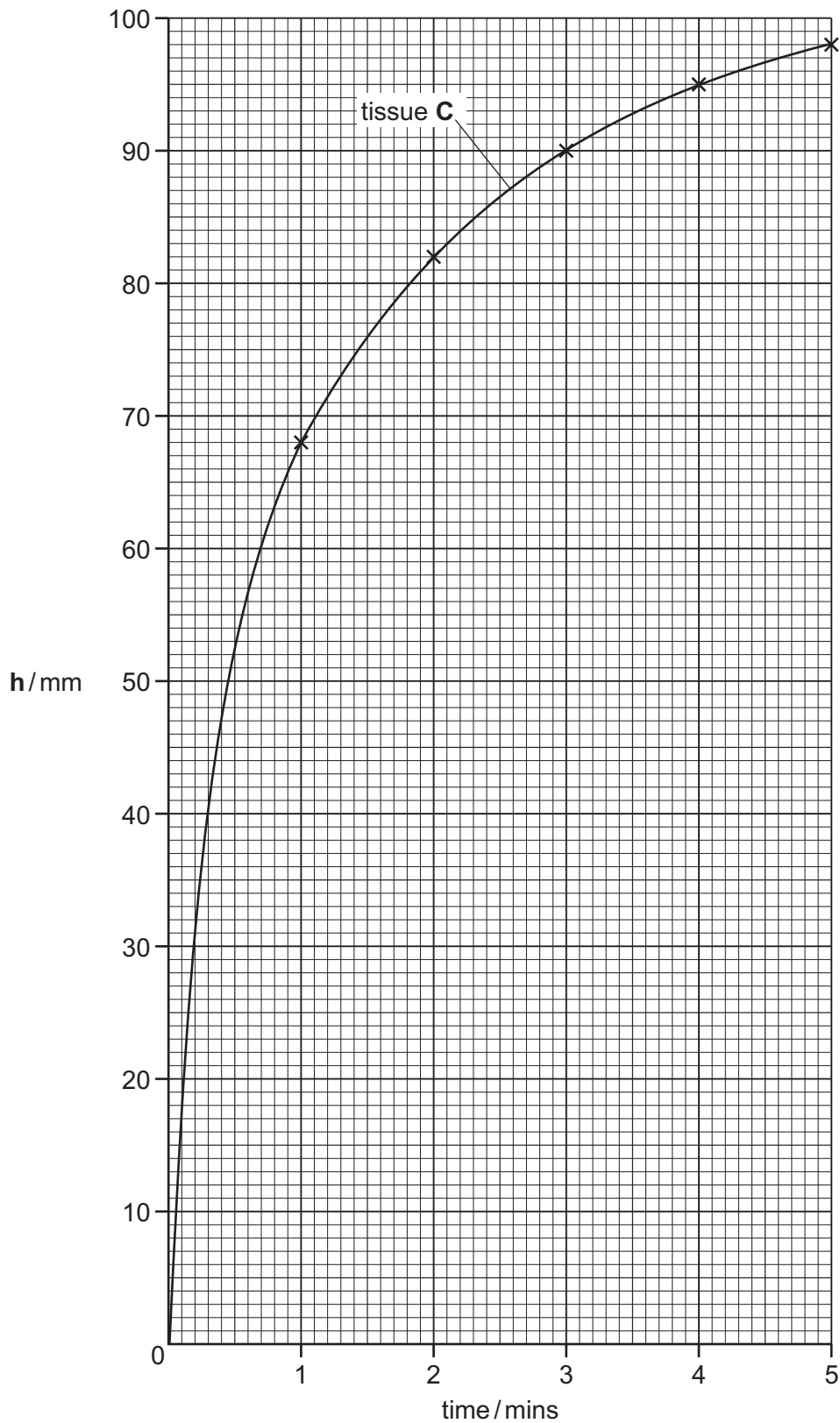

Fig. 1.3

(c) (i) In which tissue, **A**, **B** or **C** was the catalase most active?

.....

How did you decide? .....

..... [2]

(ii) Suggest how the activity of tissue **C** helps the animal.

.....

..... [2]

(d) Look at the graph for tissue **C**.  
By how much did the foam increase

(i) between 0 and 2 minutes, ..... mm

(ii) between 3 and 5 minutes? ..... mm [2]

(e) Suggest a reason for the difference between the values of **d(i)** and **d(ii)**.

.....

..... [1]

(f) How can the experiment be adapted to measure the volume of oxygen gas produced?  
You may use a diagram to illustrate your answer.

.....

.....

..... [2]

**Please turn over for Question 2.**

2 You are going to find the internal diameter,  $d$ , of the large test-tube provided.

For  
Examiner's  
Use

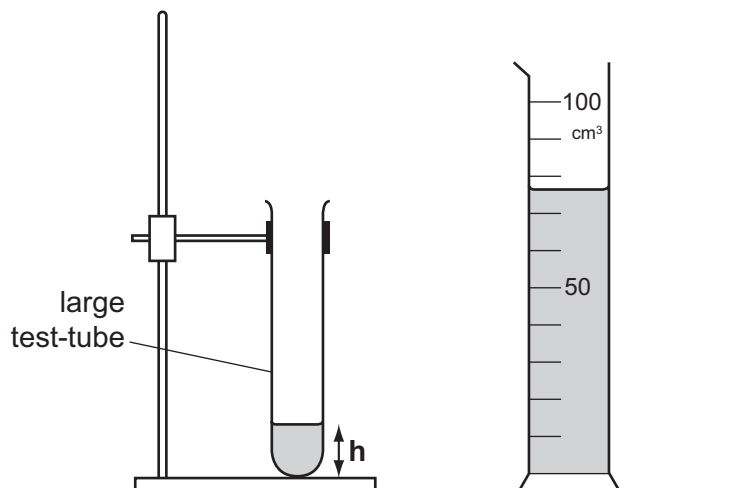

(a)

- Fill the measuring cylinder with water to the  $100\text{ cm}^3$  mark.
- Clamp the test-tube vertically.
- Add water from the measuring cylinder until the test-tube is about one-fifth full.
- Measure to the nearest millimetre the height,  $h$ , of the water level above the base of the test-tube. Record it in Fig. 2.1.
- Record the reading,  $V$ , of the water left in the measuring cylinder.

$h/\text{mm}$	$V/\text{cm}^3$	$(100 - V)/\text{cm}^3$

Fig. 2.1

[3]

- (b) (i) Add another portion (about  $10\text{ cm}^3$ ) of water from the measuring cylinder to the test-tube. Measure and record the new height,  $h$ , and the reading,  $V$ , of the water left in the measuring cylinder.
- (ii) Repeat (i) to obtain three further sets of readings of  $h$  and  $V$ . For the last reading the test-tube should be about three quarters full.

Record your readings in Fig. 2.1.

- (c) Complete Fig. 2.1 by calculating the values of  $(100 - V)$

[1]

(d) On the grid provided, plot a graph of  $(100 - V)$  on the vertical axis against  $h$ .

Draw the best straight line through your points.

[4]

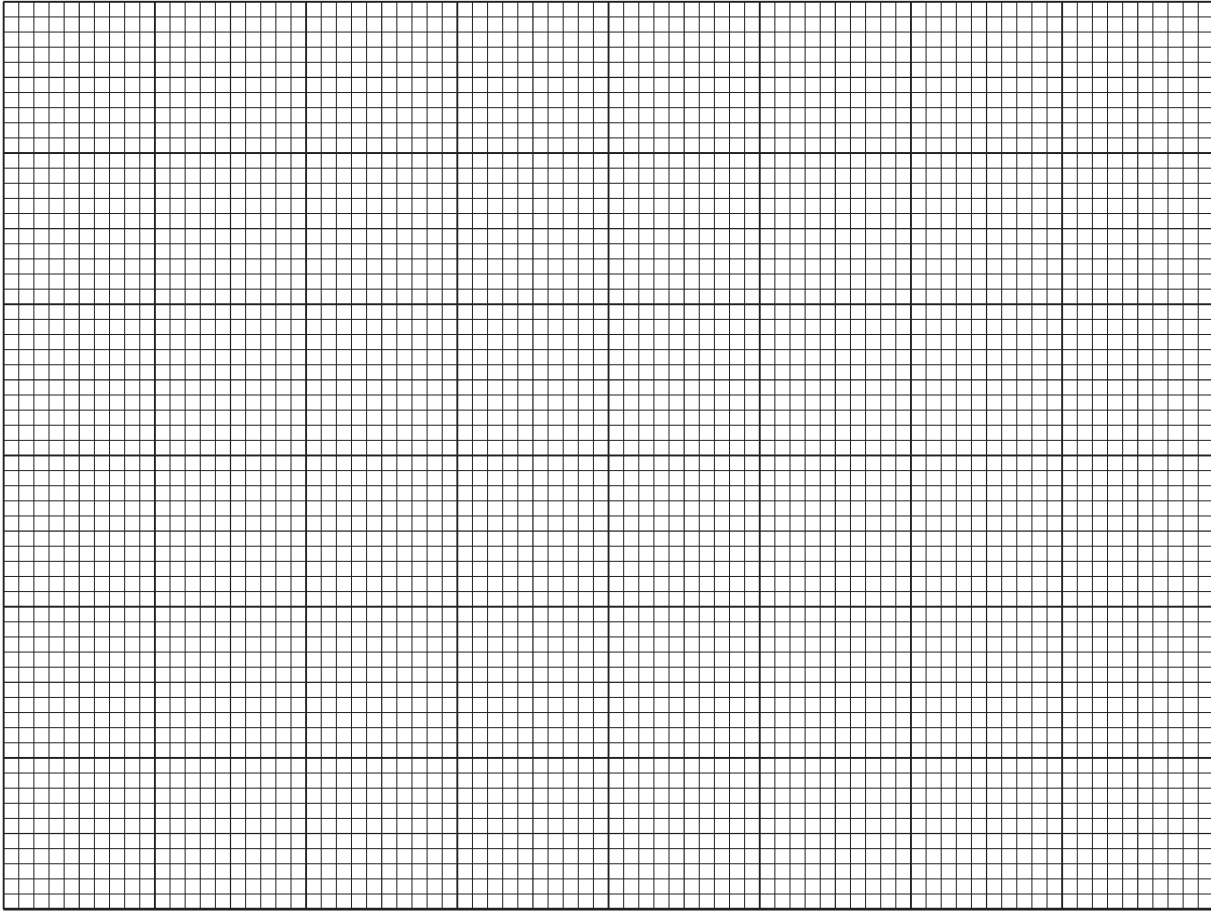

For  
Examiner's  
Use

(e) Use your graph to find the volume,  $V_w$ , of water between the heights  $h = 30$  mm and  $h = 100$  mm.

Show on your graph how you did this.

$V_w = \dots\dots\dots \text{cm}^3$  [2]

(f) Calculate the internal diameter,  $d$ , of the tube using the equation

$$d = \frac{\sqrt{V_w}}{0.24}$$

$d = \dots\dots\dots \text{mm}$  [2]

(g) Describe how you would use a long piece of string and a metre rule to measure, as accurately as possible, the outer diameter of the tube.

*For  
Examiner's  
Use*

.....

.....

.....

..... [3]



3 Divide the solid **P** into three roughly equal parts.

(a) Describe the appearance of solid **P**.

..... [1]

(b) (i) Place a portion of solid **P** on a piece of porcelain and heat it strongly.

Observe and record any change in the space below. Allow the residue to cool.

observation ..... [1]

(ii) Transfer the residue to a test-tube. Add about 2 cm<sup>3</sup> of dilute hydrochloric acid and warm gently. Allow the mixture to cool. Add water to fill the tube.

Record all your observations.

observations .....

.....

..... [3]

(c) Place a fresh portion of solid **P** in the large test-tube. Add about 10 cm<sup>3</sup> of dilute sulfuric acid. Heat until just boiling and place in the rack to cool. When the mixture is cool enough to handle, filter it and collect the filtrate.

(i) Describe the appearance of the residue in the filter paper and the appearance of the filtrate.

residue .....

filtrate ..... [2]

(ii) Place about 2 cm<sup>3</sup> of the cooled filtrate in a test-tube. Add an equal volume of potassium iodide solution. Now add about 5 cm<sup>3</sup> of solution **X**.

Record all your observations.

observations .....

.....

..... [2]

For  
Examiner's  
Use

- (iii) Place another 2 cm<sup>3</sup> of the cooled filtrate in a test-tube. Add a small portion of zinc powder. Shake the test-tube and contents and place in the rack. Observe the contents after about two minutes.

Record all your observations.

observations .....

..... [2]

- (d) Place the third portion of solid **P** in a test-tube. Add about 5 cm<sup>3</sup> of dilute nitric acid and warm gently.

Record all your observations.

observations .....

.....

..... [3]

- (e) Name the cation in solid **P**.

name of cation ..... [1]



## CHEMISTRY PRACTICAL NOTES

## Test for anions

<i>anion</i>	<i>test</i>	<i>test result</i>
carbonate ( $\text{CO}_3^{2-}$ )	add dilute acid	effervescence, carbon dioxide produced
chloride ( $\text{Cl}^-$ ) [in solution]	acidify with dilute nitric acid, then add aqueous silver nitrate	white ppt.
nitrate ( $\text{NO}_3^-$ ) [in solution]	add aqueous sodium hydroxide then aluminium foil; warm carefully	ammonia produced
sulfate ( $\text{SO}_4^{2-}$ ) [in solution]	acidify then add aqueous barium chloride <i>or</i> aqueous barium nitrate	white ppt.

## Test for aqueous cations

<i>cation</i>	<i>effect of aqueous sodium hydroxide</i>	<i>effect of aqueous ammonia</i>
ammonium ( $\text{NH}_4^+$ )	ammonia produced on warming	-
copper(II) ( $\text{Cu}^{2+}$ )	light blue ppt., insoluble in excess	light blue ppt., soluble in excess giving a dark blue solution
iron(II) ( $\text{Fe}^{2+}$ )	green ppt., insoluble in excess	green ppt., insoluble in excess
iron(III) ( $\text{Fe}^{3+}$ )	red-brown ppt., insoluble in excess	red-brown ppt., insoluble in excess
zinc ( $\text{Zn}^{2+}$ )	white ppt., soluble in excess giving a colourless solution	white ppt., soluble in excess giving a colourless solution

## Test for gases

<i>gas</i>	<i>test and test results</i>
ammonia ( $\text{NH}_3$ )	turns damp red litmus paper blue
carbon dioxide ( $\text{CO}_2$ )	turns limewater milky
chlorine ( $\text{Cl}_2$ )	bleaches damp litmus paper
hydrogen ( $\text{H}_2$ )	"pops" with a lighted splint
oxygen ( $\text{O}_2$ )	relights a glowing splint

Permission to reproduce items where third-party owned material protected by copyright is included has been sought and cleared where possible. Every reasonable effort has been made by the publisher (UCLES) to trace copyright holders, but if any items requiring clearance have unwittingly been included, the publisher will be pleased to make amends at the earliest possible opportunity.

University of Cambridge International Examinations is part of the Cambridge Assessment Group. Cambridge Assessment is the brand name of University of Cambridge Local Examinations Syndicate (UCLES), which is itself a department of the University of Cambridge.