



UNIVERSITY OF CAMBRIDGE INTERNATIONAL EXAMINATIONS
International General Certificate of Secondary Education

CANDIDATE
NAME

CENTRE
NUMBER

--	--	--	--	--

CANDIDATE
NUMBER

--	--	--	--	--

* 6 9 5 1 2 5 8 1 0 3 *

CO-ORDINATED SCIENCES

0654/22

Paper 2 (Core)

May/June 2010

2 hours

Candidates answer on the Question Paper.

No Additional Materials are required.

READ THESE INSTRUCTIONS FIRST

Write your Centre number, candidate number and name on all the work you hand in.

Write in dark blue or black pen.

You may use a soft pencil for any diagrams, graphs, tables or rough working.

Do not use staples, paper clips, highlighters, glue or correction fluid.

DO NOT WRITE IN ANY BARCODES.

Answer **all** questions.

A copy of the Periodic Table is printed on page 24.

At the end of the examination, fasten all your work securely together.

The number of marks is given in brackets [] at the end of each question or part question.

For Examiner's Use	
1	
2	
3	
4	
5	
6	
7	
8	
9	
Total	

This document consists of **23** printed pages and **1** blank page.



- 1 (a) Complete the diagram in Fig. 1.1 to show the energy transfers in a power station fuelled by a nuclear reactor.

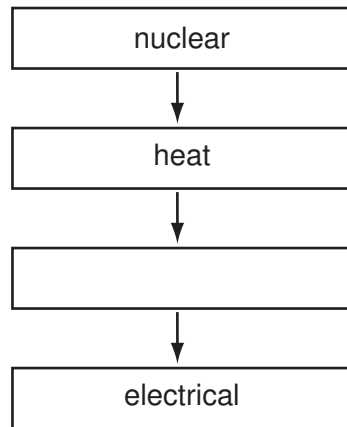

Fig. 1.1

[1]

- (b) Name **one** nuclear fuel.

..... [1]

- (c) (i) Coal is a non-renewable energy source.

Explain what is meant by the term *non-renewable*.

.....
..... [1]

- (ii) State **one** example of a renewable energy source that can be used to generate electricity.

..... [1]

- (iii) State **one** advantage of a nuclear power station over a coal-burning power station.

.....
..... [1]

- (d) Explain why electricity is transmitted at high voltage.

Your answer should include ideas about current, voltage and energy loss.

.....
.....
..... [2]

- (e) One of the waste products formed in nuclear power stations is the isotope strontium-90.

For
Examiner's
Use

Strontium-90, like other waste products from nuclear reactors, has been produced by nuclear fission.

- (i) State what happens to the nuclei of atoms during nuclear fission.

..... [1]

- (ii) Strontium-90 decays by beta particle emission. What is a beta particle?

..... [1]

- 2 (a) In Fig. 2.1 the substances in the left hand column are all proteins found in the human body.

Draw lines to link each protein to its function.

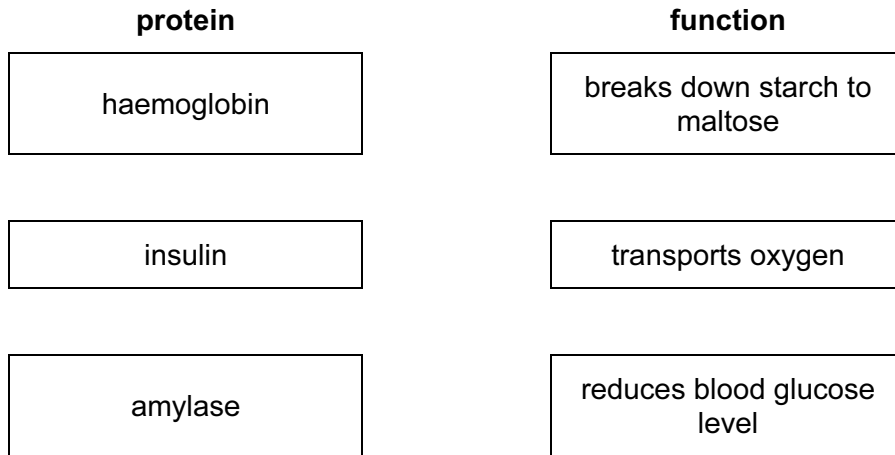

[2]

Fig. 2.1

- (b) List the four elements found in all proteins.

..... [2]

- (c) Two food samples were tested with iodine solution, Benedict's reagent and biuret reagent. The results are shown in Table 2.1.

Table 2.1

	food sample A	food sample B
colour after iodine test	brown	blue-black
colour after Benedict's test	orange-red	orange-red
colour after biuret test	purple	blue

State which food or foods contained protein.

Explain your answer.

.....

 [2]

(d) When a person eats more protein than can be immediately used in the body, the excess protein is broken down to produce the waste product urea.

Name the organ in which urea is produced. [1]

(e) Suggest how a nitrogen atom in a molecule of nitrogen gas in the atmosphere could become part of a protein in a plant.

.....
.....
.....
.....
..... [3]

- 3 (a) Electrolysis is used in industry to convert the raw material, salt (sodium chloride), into three valuable products.

Two of these products are chlorine and sodium hydroxide solution.

A simplified diagram of the apparatus is shown in Fig. 3.1.

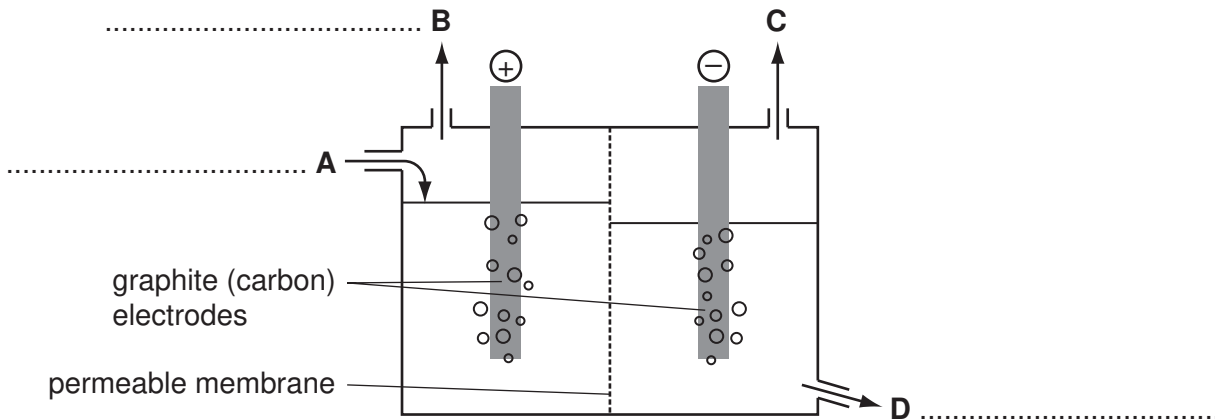

Fig. 3.1

- (i) The product which leaves the apparatus at point **C** is a colourless gas which burns with a squeaky pop.

State the name or chemical formula of this gas.

..... [1]

- (ii) Suggest the names or formulae of the chemicals found at points **A**, **B** and **D** in Fig. 3.1.

Write your answers on the diagram in Fig. 3.1. [2]

- (iii) State **two** properties of graphite (carbon) which make it a suitable material from which to make the electrodes.

..... [2]

- (iv) Describe a safe chemical test for chlorine.

..... [2]

- (b) Sucralose is a compound which is used instead of sucrose (sugar) to sweeten food and drink. Table 3.1 contains information about sucrose and sucralose.

For
Examiner's
Use

Table 3.1

	chemical formula	kilojoules in 1 gram
sucrose	$C_{12}H_{22}O_{11}$	17
sucralose	$C_{12}H_{19}O_8Cl_3$	0

- (i) Explain which compound, sucrose or sucralose, is a carbohydrate.

.....
..... [1]

- (ii) State the total number of atoms which are combined in one molecule of sucralose.

..... [1]

- (iii) Sweeteners containing sucralose are more expensive than sucrose, but one gram tastes much sweeter than one gram of sucrose.

Suggest why people might prefer to use sweeteners containing sucralose rather than sucrose.

.....
.....
..... [2]

- 4 (a) Fig. 4.1 shows forces acting on three blocks. The size of an arrow indicates the size of the force it represents.

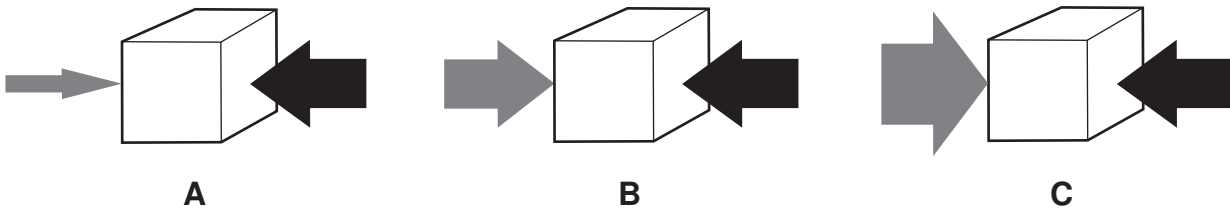

Fig. 4.1

- (i) Which of the blocks would start to move?

Explain your answer.

blocks

explanation

..... [2]

- (ii) On the blocks in Fig. 4.1 that move, draw another arrow to show the direction of motion. [1]

- (iii) Name **one** force which acts downwards on all the blocks.

..... [1]

- (iv) State the source of this force.

..... [1]

- (b) One of the blocks has a mass of 720g and a volume of 80 cm³.

Calculate the density of the block.

State the formula that you use and show your working.

formula

working

..... g/cm³ [2]

(c) A student tested a block to see if it conducted electricity.

Draw a simple circuit which the student could build for this purpose. Use the correct circuit symbols.

*For
Examiner's
Use*

[3]

5 (a) Fig. 5.1 shows how light intensity affects the rate of photosynthesis of a plant.

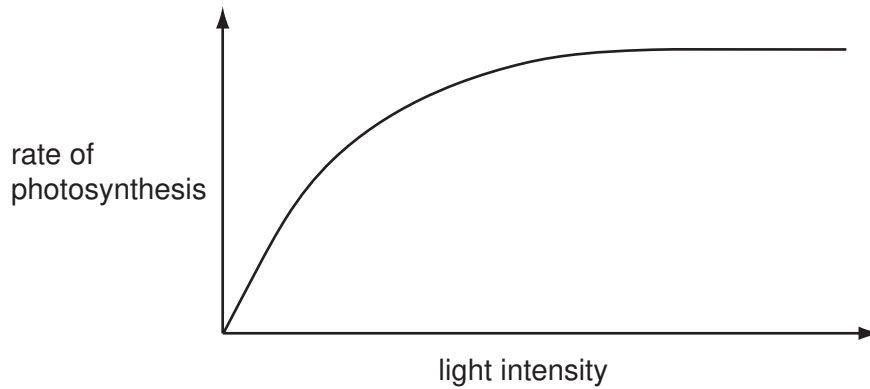

Fig. 5.1

(i) Describe the relationship between light intensity and the rate of photosynthesis.

.....

 [2]

(ii) Explain why light is needed for photosynthesis.

.....

 [2]

(b) The diagrams in Fig. 5.2 show sections through two leaves on the same tree. The two diagrams are drawn to the same scale.

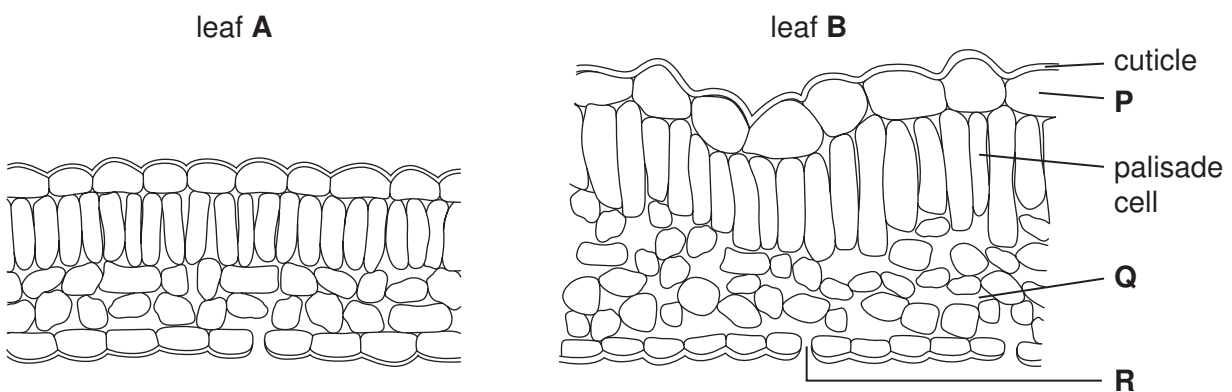

Fig. 5.2

(i) Name the parts labelled P, Q and R on Fig. 5.2.

P

Q

R

[3]

- (ii) Leaf **A** was taken from a part of the tree that was always in the shade.
Leaf **B** was taken from a part of the tree that received plenty of sunlight.

Both leaves are put into bright light.

Using Fig. 5.2, suggest in which leaf photosynthesis will happen faster in these conditions. Explain your answer.

leaf

explanation

..... [1]

- (iii) Suggest why leaf **B** has a thicker cuticle than leaf **A**.

.....

.....

..... [2]

- (iv) Describe how carbon dioxide travels to a palisade cell in a leaf.

.....

.....

.....

..... [3]

- (c) The differences between leaf **A** and leaf **B** are an example of variation.

State whether this variation is caused by

- genes,
- the environment,
- both genes and environment together.

Explain your answer.

cause of variation

explanation

..... [2]

6 (a) Solutions of substances in water are acidic, neutral or alkaline.

Choose pH values from the list below to complete Table 6.1.

list of pH values 2 5 7 9 13

Table 6.1

liquid	description	pH
sodium chloride solution	neutral	
lemonade (a fizzy drink)	weakly acidic	

[2]

(b) A student used the apparatus shown in Fig. 6.1 to investigate the reaction between dilute hydrochloric acid and magnesium.

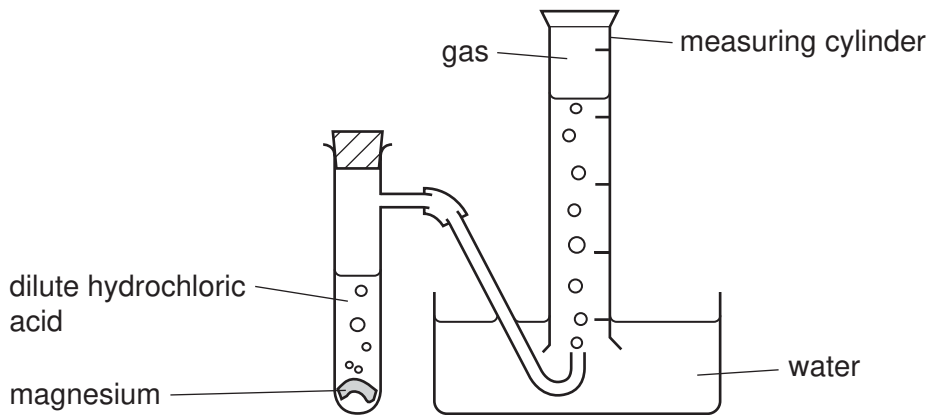

Fig. 6.1

(i) The student made several observations and measurements during her investigation.

Suggest and explain an observation which would show that the reaction between magnesium and dilute hydrochloric acid is *exothermic*.

.....

.....

..... [2]

(ii) State **two** changes which the student could make to the reaction conditions so that the gas collected more **slowly** in the measuring cylinder.

1

.....

2

..... [2]

(iii) Complete the word equation for the reaction between dilute hydrochloric acid and magnesium.

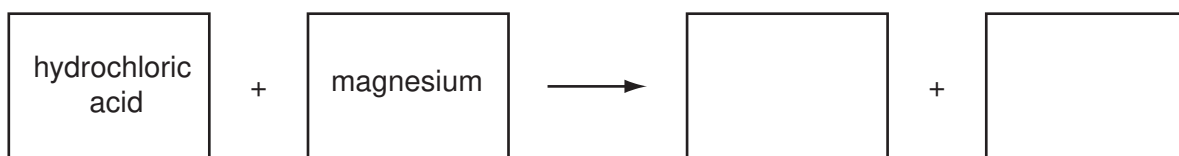

[2]

(c) Magnesium, Mg, is a metallic element.

(i) Explain the meaning of both words in the term *metallic element*.

metallic

.....

element

..... [2]

(ii) Name **one** other element which is in the same group of the Periodic Table as magnesium.

..... [1]

(iii) An atom of magnesium has a nucleon (mass) number of 26.

Calculate the number of neutrons in this magnesium atom.

Use the Periodic Table on page 24.

Show your working.

..... [1]

7 (a) A racing car is being driven in a race.

The graph in Fig. 7.1 shows the speed of the car over a 26 second period.

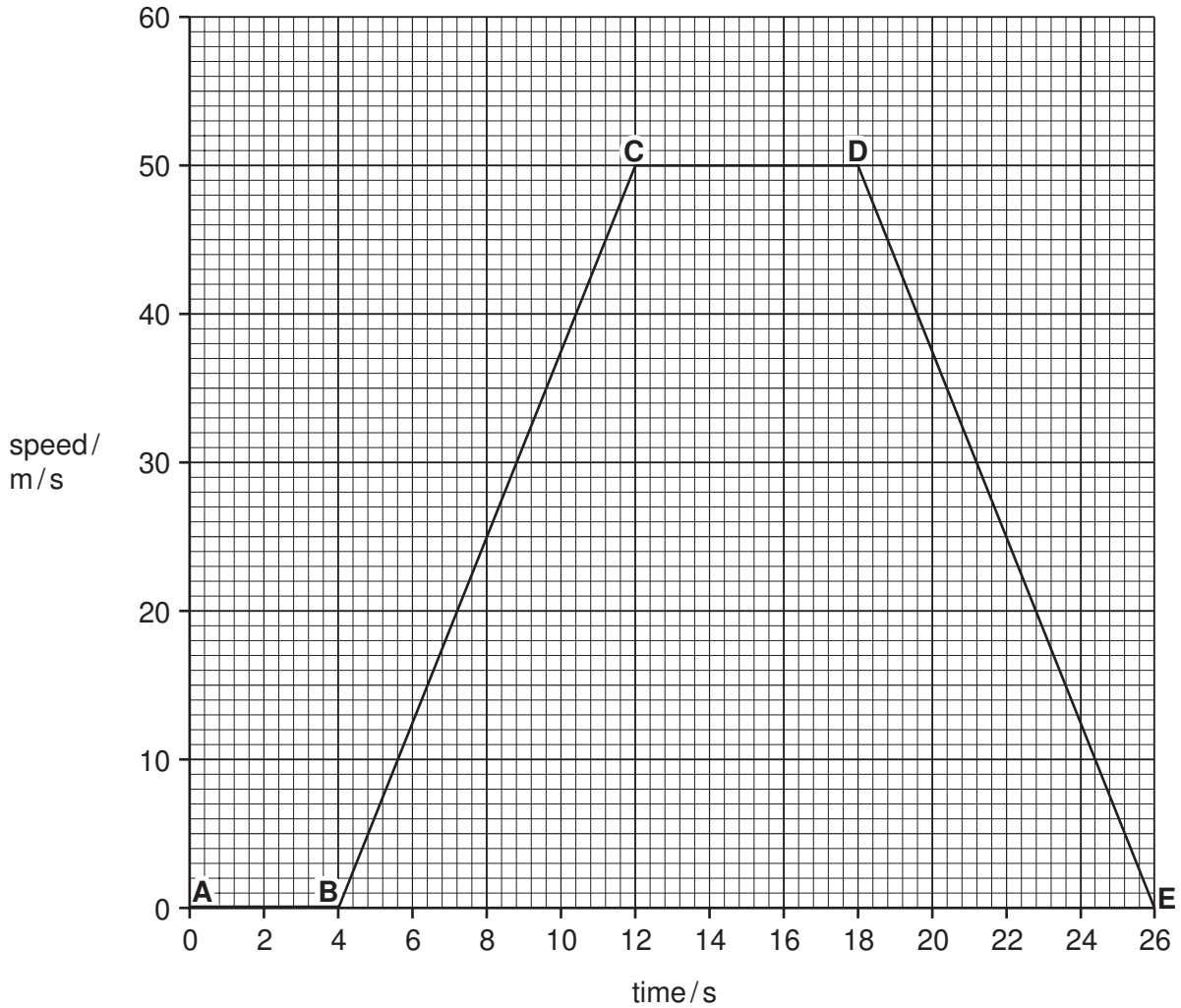

Fig. 7.1

(i) Between which points on the graph is the car not moving?

..... [1]

(ii) State the speed of the car between C and D.

..... m/s [1]

- (iii) The mass of the car and driver is 600 kg.

Calculate the momentum of the car between **C** and **D**.

State the formula that you use and show your working.

formula

working

..... kg m/s [2]

- (iv) Calculate the acceleration of the car between **B** and **C**.

Show your working.

..... m/s² [2]

(b) A wheel on a car needs changing. Fig. 7.2 shows a spanner of length 0.3 m being used to turn a wheel nut.

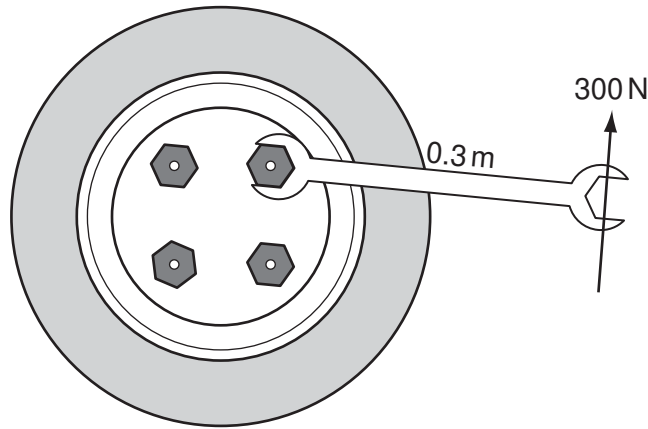

Fig. 7.2

(i) Calculate the turning effect (moment) of the spanner.

State the formula that you use and show your working.

formula

working

..... Nm [2]

(ii) Give **two** ways in which you can increase the spanner's turning effect.

1

2 [2]

(c) A car has been painted blue. Blue is a primary colour of light.

Name the **two** other primary colours of light.

..... and [1]

Please turn over for Question 8.

- 8 Sprinters need fast reflexes to make a good start in a 100 m race. They respond to the sound of the starting gun by pushing off from their starting blocks as fast as they can.

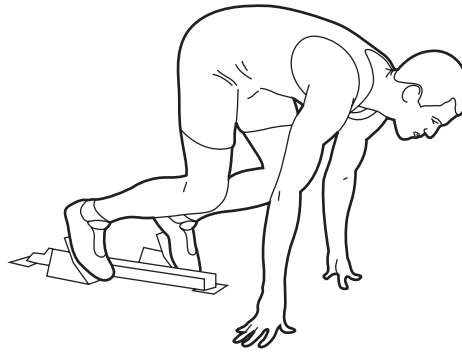

Fig. 8.1

- (a) Choose the correct word from the list to identify the stimulus, receptor and effector in this response.

ear eye muscle sprinter sound

stimulus

receptor

effector

[3]

- (b) The time between the starting gun being fired and the runner pushing off from the starting blocks is known as the reaction time.

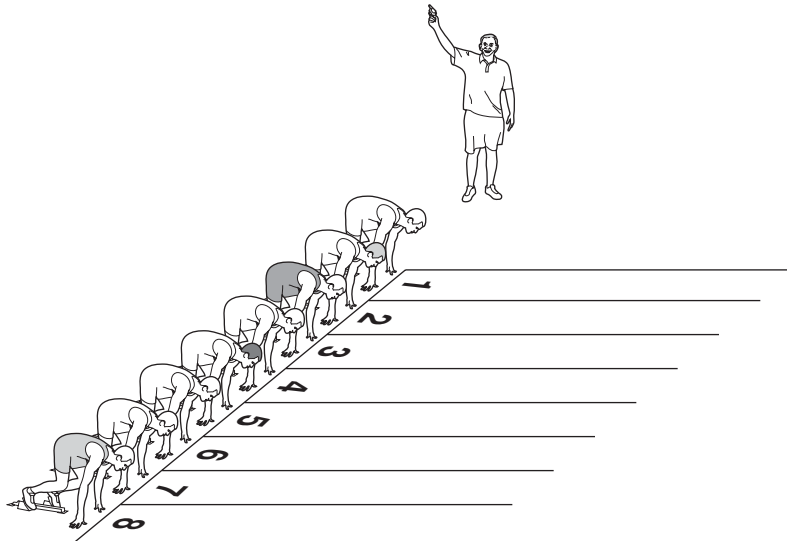

Fig. 8.2

The reaction time is made up of:

- the time taken for the sound from the starting gun to reach the runner's ear,
- plus the time taken for a nerve impulse to pass from the ear to the brain,
- plus the time taken for a nerve impulse to pass from the brain to the leg muscles.

- (i) A runner in lane 1 is 2 m from the starting gun. Sound travels at 330 m/s.
Calculate the time taken for the sound to reach the runner's ear.
Show your working.

..... s [2]

Table 8.1 shows the reaction times of the runners in lane 1 and lane 8 in the heats (qualifying races) for a 100 m race.

Table 8.1

	reaction time / s							
	heat 1	heat 2	heat 3	heat 4	heat 5	heat 6	heat 7	heat 8
lane 1	0.133	0.146	0.170	0.160	0.186	0.176	0.149	0.147
lane 8	0.228	0.223	0.188	0.195	0.178	0.199	0.163	0.167

- (ii) Draw a ring around the heat that shows anomalous results. [1]
- (iii) In which lane did the runners have the longer reaction times? Suggest a reason for this.

lane

reason

..... [1]

(c) During a sprint race, a runner's muscle cells use anaerobic respiration.

(i) Explain what is meant by *anaerobic respiration*.

.....
.....
..... [2]

(ii) Name the waste substance that is made when anaerobic respiration takes place in human cells.

..... [1]

(iii) Describe how the body gets rid of this waste substance after the race is over.

.....
.....
..... [2]

9 Fig. 9.1 shows part of the water cycle.

P shows where liquid water is evaporating into water vapour which rises and then condenses back into drops of liquid water in clouds.

Q shows where rain is falling. The rainwater collects in streams and rivers which flow over rocks in the Earth's crust.

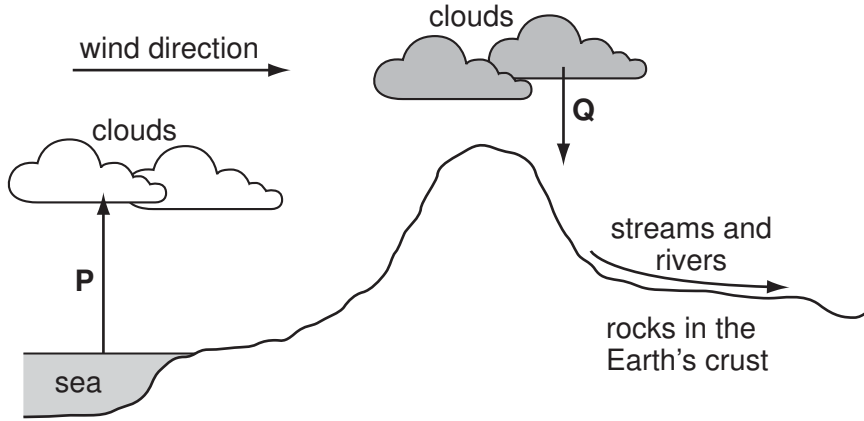

Fig. 9.1

(a) State briefly what happens to the rising water vapour, **P**, in Fig. 9.1 which causes it to condense.

..... [1]

(b) Water molecules contain the elements hydrogen and oxygen.

A student thinks that the oxygen in water should relight a glowing wooden splint.

Explain why a glowing wooden splint does **not** relight when placed into a test-tube full of water vapour.

.....
.....
..... [2]

(c) The rocks in the Earth's crust undergo weathering and erosion which are important processes in the formation of clay.

(i) State what must be done to objects made of clay to change them into rigid ceramic objects such as dinner plates.

..... [1]

(ii) Carbon is a non-metallic element.

Explain why rainwater which contains dissolved carbon dioxide causes chemical weathering of limestone rocks.

.....
.....
.....
..... [3]

(d) Fig. 9.2 shows a simplified diagram of a machine used to wash dishes.

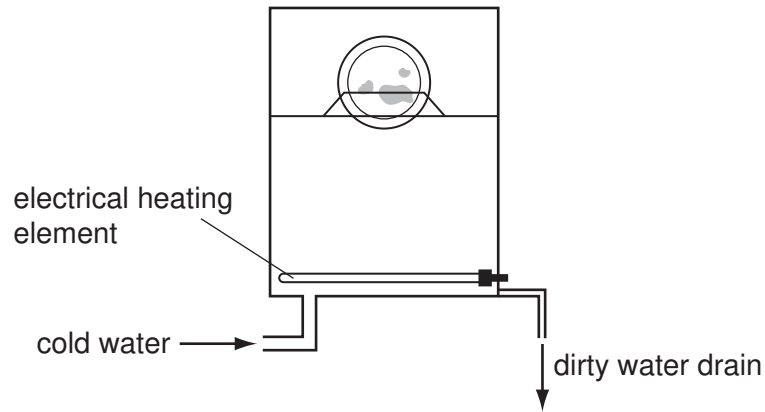

Fig. 9.2

In this machine the water, which is to be used to clean the dishes is first heated to a high temperature and then a detergent is added.

(i) Describe **one** disadvantage of using hard water rather than soft water in this machine.

.....
 [1]

(ii) Name a metallic element whose compounds cause hardness in water.

..... [1]

(iii) Explain briefly the advantage of adding a detergent to the water in the machine.

.....
 [1]

DATA SHEET
The Periodic Table of the Elements

		Group																																																																																																																																																																																																																																																																																																																																																																																																																																																																																																																																																																																																																																																																																																																																																																																																																																																																																																																																																																																																																			
		I	II	III	IV	V	VI	VII	VIII	IX	X																																																																																																																																																																																																																																																																																																																																																																																																																																																																																																																																																																																																																																																																																																																																																																																																																																																																																																																																																																																																										
		1 H Hydrogen 1																																																																																																																																																																																																																																																																																																																																																																																																																																																																																																																																																																																																																																																																																																																																																																																																																																																																																																																																																																																																																			
7	9	3	4	5	6	7	8	9	10	11	12	13	14	15	16	17	18	19	20																																																																																																																																																																																																																																																																																																																																																																																																																																																																																																																																																																																																																																																																																																																																																																																																																																																																																																																																																																																																		
Li Lithium	Be Beryllium	B Boron	C Carbon	N Nitrogen	O Oxygen	F Fluorine	Ne Neon	Na Sodium	Mg Magnesium	Al Aluminium	Si Silicon	P Phosphorus	S Sulfur	Cl Chlorine	Ar Argon	K Potassium	Ca Calcium	Sc Scandium	Ti Titanium	V Vanadium	Cr Chromium	Mn Manganese	Fe Iron	Co Cobalt	Ni Nickel	Cu Copper	Zn Zinc	Ga Gallium	Ge Germanium	As Arsenic	Se Selenium	Br Bromine	Kr Krypton																																																																																																																																																																																																																																																																																																																																																																																																																																																																																																																																																																																																																																																																																																																																																																																																																																																																																																																																																																																				
23	24	11	12	13	14	15	16	27	28	29	30	31	32	33	34	35	36	37	38	39	40	41	42	43	44	45	46	47	48	49	50	51	52	53	54	55	56	57	58	59	60	61	62	63	64	65	66	67	68	69	70	71	72	73	74	75	76	77	78	79	80	81	82	83	84	85	86	87	88	89	90	91	92	93	94	95	96	97	98	99	100	101	102	103	104	105	106	107	108	109	110	111	112	113	114	115	116	117	118	119	120	121	122	123	124	125	126	127	128	129	130	131	132	133	134	135	136	137	138	139	140	141	142	143	144	145	146	147	148	149	150	151	152	153	154	155	156	157	158	159	160	161	162	163	164	165	166	167	168	169	170	171	172	173	174	175	176	177	178	179	180	181	182	183	184	185	186	187	188	189	190	191	192	193	194	195	196	197	198	199	200	201	202	203	204	205	206	207	208	209	210	211	212	213	214	215	216	217	218	219	220	221	222	223	224	225	226	227	228	229	230	231	232	233	234	235	236	237	238	239	240	241	242	243	244	245	246	247	248	249	250	251	252	253	254	255	256	257	258	259	260	261	262	263	264	265	266	267	268	269	270	271	272	273	274	275	276	277	278	279	280	281	282	283	284	285	286	287	288	289	290	291	292	293	294	295	296	297	298	299	300	301	302	303	304	305	306	307	308	309	310	311	312	313	314	315	316	317	318	319	320	321	322	323	324	325	326	327	328	329	330	331	332	333	334	335	336	337	338	339	340	341	342	343	344	345	346	347	348	349	350	351	352	353	354	355	356	357	358	359	360	361	362	363	364	365	366	367	368	369	370	371	372	373	374	375	376	377	378	379	380	381	382	383	384	385	386	387	388	389	390	391	392	393	394	395	396	397	398	399	400	401	402	403	404	405	406	407	408	409	410	411	412	413	414	415	416	417	418	419	420	421	422	423	424	425	426	427	428	429	430	431	432	433	434	435	436	437	438	439	440	441	442	443	444	445	446	447	448	449	450	451	452	453	454	455	456	457	458	459	460	461	462	463	464	465	466	467	468	469	470	471	472	473	474	475	476	477	478	479	480	481	482	483	484	485	486	487	488	489	490	491	492	493	494	495	496	497	498	499	500	501	502	503	504	505	506	507	508	509	510	511	512	513	514	515	516	517	518	519	520	521	522	523	524	525	526	527	528	529	530	531	532	533	534	535	536	537	538	539	540	541	542	543	544	545	546	547	548	549	550	551	552	553	554	555	556	557	558	559	560	561	562	563	564	565	566	567	568	569	570	571	572	573	574	575	576	577	578	579	580	581	582	583	584	585	586	587	588	589	590	591	592	593	594	595	596	597	598	599	600	601	602	603	604	605	606	607	608	609	610	611	612	613	614	615	616	617	618	619	620	621	622	623	624	625	626	627	628	629	630	631	632	633	634	635	636	637	638	639	640	641	642	643	644	645	646	647	648	649	650	651	652	653	654	655	656	657	658	659	660	661	662	663	664	665	666	667	668	669	670	671	672	673	674	675	676	677	678	679	680	681	682	683	684	685	686	687	688	689	690	691	692	693	694	695	696	697	698	699	700	701	702	703	704	705	706	707	708	709	710	711	712	713	714	715	716	717	718	719	720	721	722	723	724	725	726	727	728	729	730	731	732	733	734	735	736	737	738	739	740	741	742	743	744	745	746	747	748	749	750	751	752	753	754	755	756	757	758	759	760	761	762	763	764	765	766	767	768	769	770	771	772	773	774	775	776	777	778	779	780	781	782	783	784	785	786	787	788	789	790	791	792	793	794	795	796	797	798	799	800	801	802	803	804	805	806	807	808	809	810	811	812	813	814	815	816	817	818	819	820	821	822	823	824	825	826	827	828	829	830	831	832	833	834	835	836	837	838	839	840	841	842	843	844	845	846	847	848	849	850	851	852	853	854	855	856	857	858	859	860	861	862	863	864	865	866	867	868	869	870	871	872	873	874	875	876	877	878	879	880	881	882	883	884	885	886	887	888	889	890	891	892	893	894	895	896	897	898	899	900	901	902	903	904	905	906	907	908	909	910	911	912	913	914	915	916	917	918	919	920	921	922	923	924	925	926	927	928	929	930	931	932	933	934	935	936	937	938	939	940	941	942	943	944	945	946	947	948	949	950	951	952	953	954	955	956	957	958	959	960	961	962	963	964	965	966	967	968	969	970	971	972	973	974	975	976	977	978	979	980	981	982	983	984	985	986	987	988	989	990	991	992	993	994	995	996	997	998	999	1000

* 58-71 Lanthanoid series
† 90-103 Actinoid series

a	X	a = relative atomic mass
b	X	X = atomic symbol
	X	b = proton (atomic) number

The volume of one mole of any gas is 24 dm³ at room temperature and pressure (r.t.p.).

Permission to reproduce items where third-party owned material protected by copyright is included has been sought and cleared where possible. Every reasonable effort has been made by the publisher (UCLES) to trace copyright holders, but if any items requiring clearance have unwittingly been included, the publisher will be pleased to make amends at the earliest possible opportunity.

University of Cambridge International Examinations is part of the Cambridge Assessment Group. Cambridge Assessment is the brand name of University of Cambridge Local Examinations Syndicate (UCLES), which is itself a department of the University of Cambridge.