



UNIVERSITY OF CAMBRIDGE INTERNATIONAL EXAMINATIONS
International General Certificate of Secondary Education

CANDIDATE
NAME

CENTRE
NUMBER

--	--	--	--	--

CANDIDATE
NUMBER

--	--	--	--

* 5 9 9 1 9 0 4 8 2 0 *

CO-ORDINATED SCIENCES

0654/63

Paper 6 Alternative to Practical

October/November 2013

1 hour

Candidates answer on the Question Paper.

No Additional Materials are required.

READ THESE INSTRUCTIONS FIRST

Write your Centre number, candidate number and name on all the work you hand in.

Write in dark blue or black pen.

You may use a pencil for any diagrams or graphs.

Do not use staples, paper clips, glue or correction fluid.

DO NOT WRITE IN ANY BARCODES.

Answer **all** questions.

Electronic calculators may be used.

You may lose marks if you do not show your working or if you do not use appropriate units.

At the end of the examination, fasten all your work securely together.

The number of marks is given in brackets [] at the end of each question or part question.

This document consists of **20** printed pages.



1 Urease is an enzyme. It converts urea to ammonia, which is alkaline.

A student did an experiment in which urease acted on acidified urea. The rate of the reaction was measured by timing how long it took for the acid in the urea solution to be neutralised by the conversion of urea to ammonia.

The student investigated the effect of changing the urease (enzyme) concentration on the rate of the reaction.

- Five test-tubes, **A**, **B**, **C**, **D** and **E**, were prepared, each containing 5 cm³ acidified urea solution, all of the same concentration.
- Five drops of Universal Indicator (full-range indicator) solution were added to each of the tubes **A** – **E**. The indicator solution turned red because of the acid.
- Five solutions of urease, each a different concentration of urease, were prepared. The concentrations were 1%, 2%, 3%, 4% and 5%.
- 5 cm³ of the 1% urease solution was added to test-tube **A**. The time taken for the indicator solution to change to a blue or green colour was measured.

The procedure was repeated with the other urease concentrations. The results are shown in Table 1.1.

Table 1.1

tube	urease concentration (%)	time taken for colour change / s
A	1	155
B	2	60
C	3	58
D	4	32
E	5	20

- (a) On the grid below, plot a graph of time taken for the colour change (vertical axis) against urease concentration (horizontal axis). Draw a best fit curve.

For
Examiner's
Use

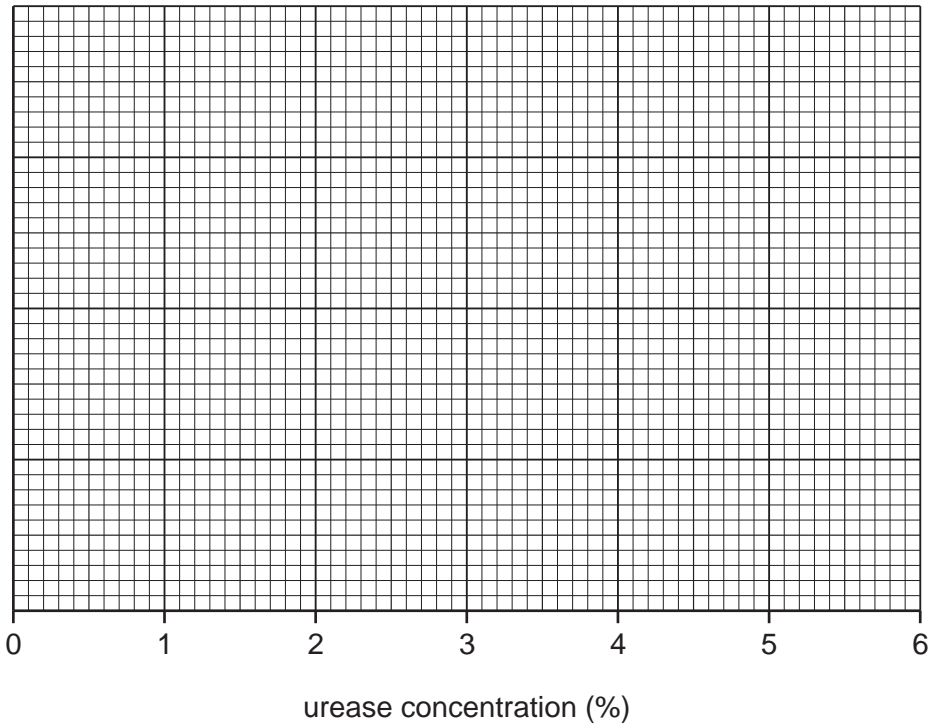

[3]

- (b) Identify any anomalous result from this experiment, and suggest a possible reason for any such result.

.....
.....
..... [1]

- (c) Use the graph to suggest how long the colour change would take for a 6% urease solution.

.....
..... [1]

(d) (i) Describe how this experiment could be modified to investigate the effect of temperature on the action of urease. Include experimental details in your answers.

*For
Examiner's
Use*

.....
.....
.....
.....
..... [3]

(ii) On the axes below, sketch the shape of the graph that would be expected from the results of an experiment investigating the effect of temperature on the action of urease.

Label the axes of the graph.



[2]

Please turn over for Question 2.

- 2 A student is investigating the resistances of two lamps, **X** and **Y**. The resistances of the two lamps are not the same.

The student connects the lamps in the circuit shown in Fig. 2.1. She closes the switch, reads the meters and records the readings in Table 2.1.

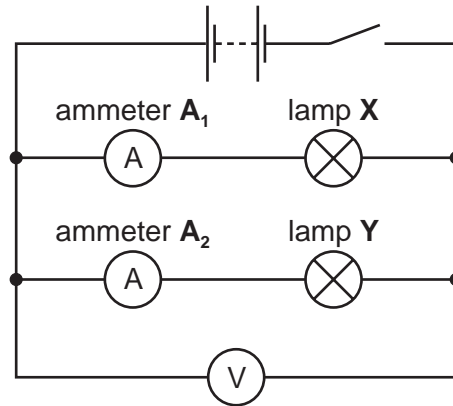

Fig. 2.1

- (a) (i) The ammeter and voltmeter dials are shown in Fig. 2.2.

Read the meters and record the readings in Table 2.1.

[3]

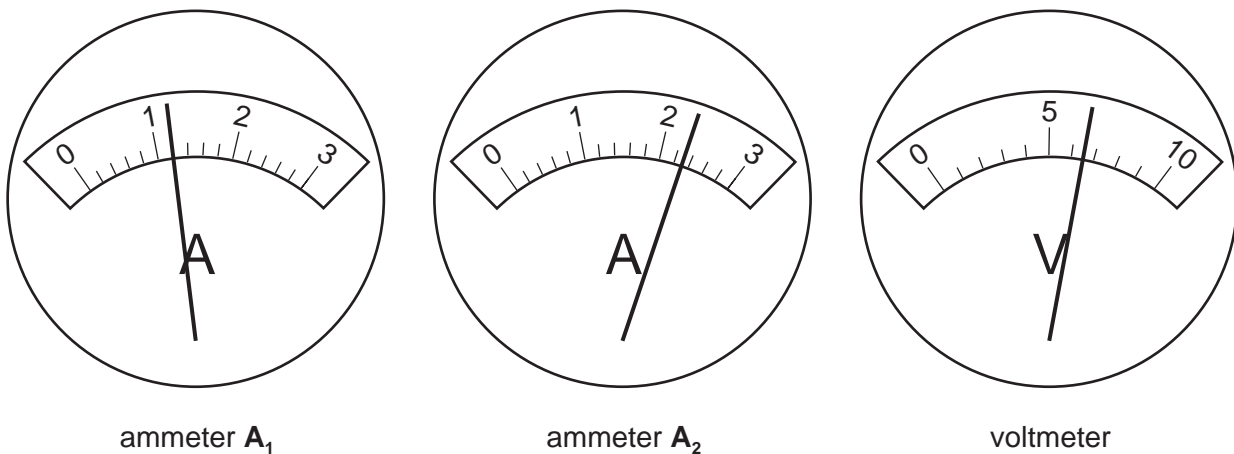

Fig. 2.2

Table 2.1

reading on ammeter A_1 / A	
reading on ammeter A_2 / A	
reading on voltmeter / V	

The student uses the data in Table 2.1 to calculate the resistance of the lamps.

She uses the equation shown below.

$$\text{resistance} = \frac{\text{voltage in volts}}{\text{current in amps}}$$

(ii) Calculate the resistance of lamp X.

resistance of lamp X = Ω [1]

(iii) Calculate the resistance of lamp Y.

resistance of lamp Y = Ω [1]

The student now connects the lamps in the circuit shown in Fig. 2.3 and closes the switch.

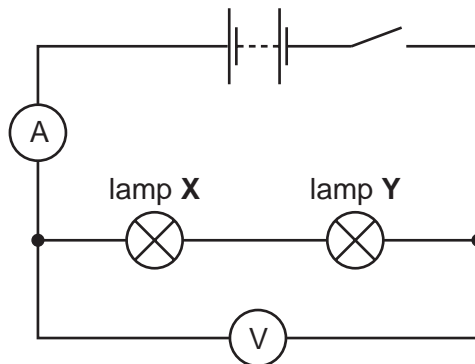

Fig. 2.3

The current shown on the ammeter is 0.75 A. The voltage is the same as in the circuit in Fig. 2.1, and on the voltmeter dial in Fig. 2.2.

(b) Calculate the combined resistance of the two lamps.

Use the equation shown in part (a).

combined resistance of the two lamps = Ω [1]

(c) The student makes the following suggestion.

"The sum of the resistances of the lamps in the parallel circuit is equal to the combined resistance in the series circuit."

Use your values from (a)(ii), (a)(iii) and (b) to comment on this suggestion. Refer to possible experimental error.

.....
.....
.....
..... [2]

(d) (i) Compare the data in Table 2.1 for the two lamps.

State what the student might observe when the lamps in the circuit shown in Fig. 2.1 on page 6 are lit.

.....
..... [1]

(ii) Compare the ammeter reading for the circuit in Fig. 2.3 on page 7 with the data in Table 2.1.

State any difference that the student will observe for the lamps in the two circuits.

.....
..... [1]

Please turn over for Question 3.

- 3 A teacher asks a student to compare the heat changes that occur when sodium hydroxide reacts with excess amounts of three different unknown acids, **A**, **B** and **C**.

For
Examiner's
Use

The three acid solutions all have the same concentration.

- The student places 20 cm³ aqueous sodium hydroxide in a flask.
- He measures the temperature using a thermometer and records it in Table 3.1.
- He adds 10 cm³ of acid **A** and stirs the mixture.
- He measures the maximum temperature reached, and records it in Table 3.1.
- He repeats the experiment using acids **B** and **C** and aqueous sodium hydroxide of the same concentration as before.

Table 3.1

acid	temperature of aqueous sodium hydroxide / °C	maximum temperature of mixture / °C	temperature change / °C
A	18.0		
B	19.5		
C	18.5		

- (a) The thermometer scales for the maximum temperatures of the mixtures of alkali and acids **A**, **B** and **C** are shown in Fig. 3.1.

Read the scales and record the temperatures in Table 3.1.

[3]

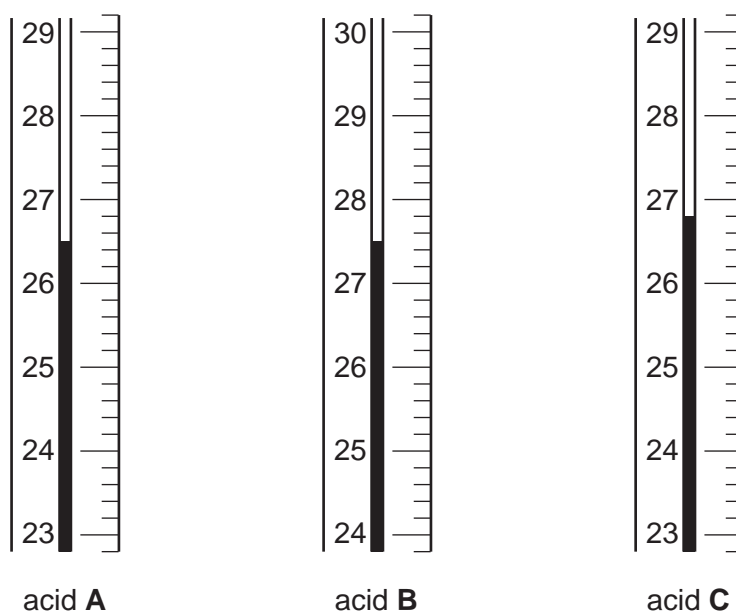

Fig. 3.1

(b) (i) Calculate the temperature change for each mixture and complete Table 3.1. [1]

(ii) Are these reactions exothermic or endothermic? Explain your answer.

.....
 [1]

(c) The teacher gives the student a chemical equation showing how the ions from the acid and the alkali react together.

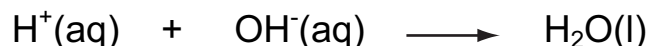

Explain, using details of the experiment and this equation, why approximately the same temperature change took place each time although three different acids were used.

.....

 [1]

(d) The student thinks that doubling the concentration of the alkali, while keeping the acid in excess, might improve the accuracy of the experiment.

In a second set of experiments he uses sodium hydroxide of double the concentration.

This time, the temperature change is about 16 °C.

Suggest why the results for this second set of experiments will have smaller percentage errors than those for the first set.

.....

 [2]

For
Examiner's
Use

- (e) The teacher asks the student to find out which of the three acids **A**, **B** and **C** is hydrochloric acid.

The student adds a few drops of a test solution to samples of the three acids. He observes a reaction and concludes that acid **A** is hydrochloric acid.

Name the test solution and state the observation that the student makes.

name of test solution

observation

..... [2]

*For
Examiner's
Use*

- 4 A student was studying some changes in the water of an aquarium containing aquatic plants. The aquarium was placed in a sunny environment.

The student used two probes to study the changes. One probe monitored the dissolved oxygen levels. The other probe monitored pH.

The pH probe was used to follow changes in carbon dioxide levels in the water. When carbon dioxide dissolves in water it produces an acidic solution. As the level of carbon dioxide dissolved increases, the pH decreases.

The probes were attached to a computer for 28 hours. Data collected from both probes were displayed as graphs on the screen of the computer as shown in Fig. 4.1.

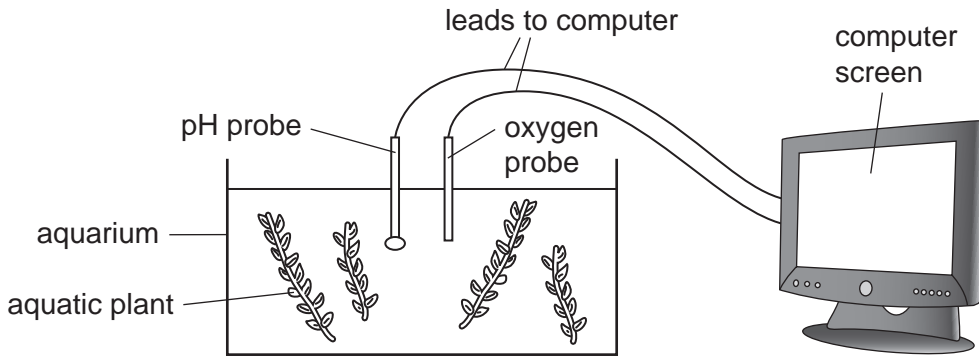

Fig. 4.1

- (a) The graph from the pH probe was printed after 28 hours. It is shown in Fig. 4.2.

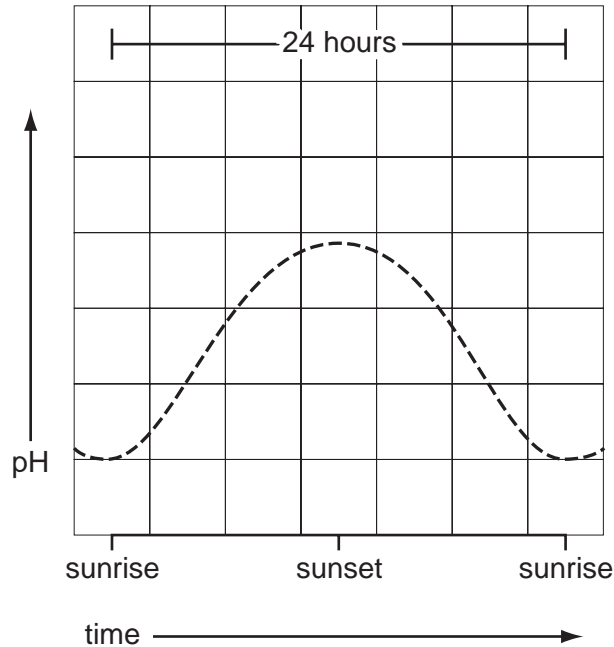

Fig. 4.2

- (i) Describe the change in pH level during the 24 hour period from sunrise to sunrise.

.....
 [1]

(ii) Describe what is happening to the concentration of carbon dioxide in the aquarium during the 24 hours.

.....
..... [1]

(iii) Explain, in terms of respiration and photosynthesis, why the carbon dioxide levels change in the aquarium during the 24 hours.

.....
.....
..... [2]

(b) Fig. 4.3 shows the oxygen curve from the experiment.

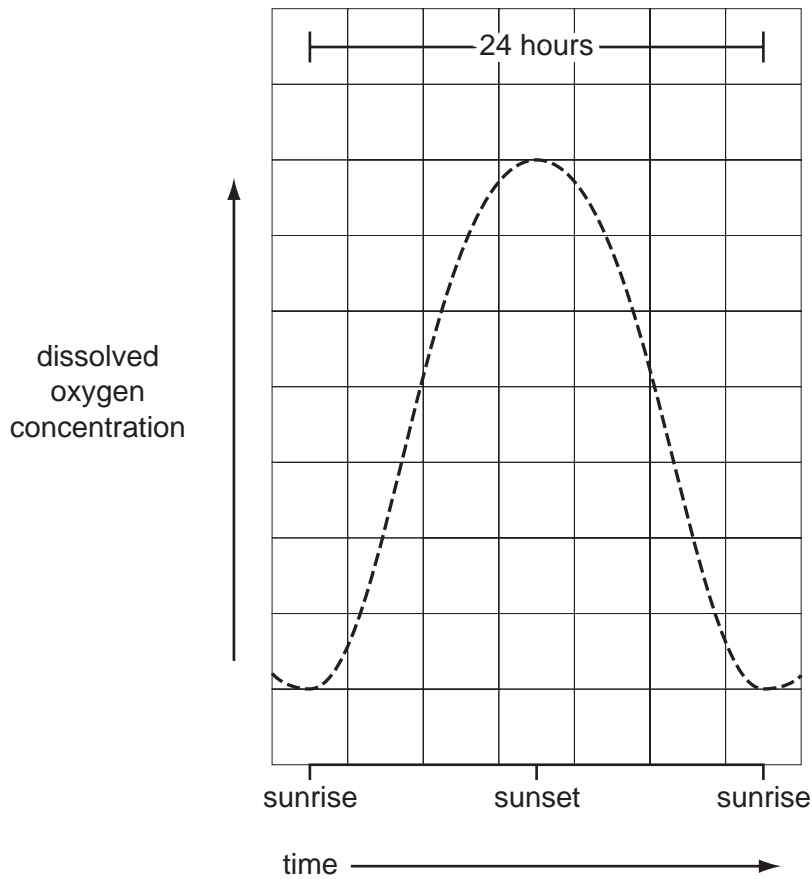

Fig 4.3

(i) Put the letter X on a part of the curve that has the fastest rate of photosynthesis. [1]

(ii) Suggest a reason for the recorded change in oxygen concentration between **sunset** and **sunrise**.

.....
..... [1]

(iii) Draw a curved line on Fig. 4.3 to show how the oxygen curve would be different during the 24 hour period if it was a cloudy day. [1]

(c) The student used the apparatus to compare the rate of photosynthesis in the aquarium at different light intensities.

Outline a method for her investigation. You should include

- how she set up the apparatus,
- how she varied the light intensity,
- what measurements she took.

.....
.....
.....
.....
.....
.....
.....
..... [3]

- 5 A student is making the salt magnesium sulfate using dilute sulfuric acid and powdered magnesium carbonate.

For
Examiner's
Use

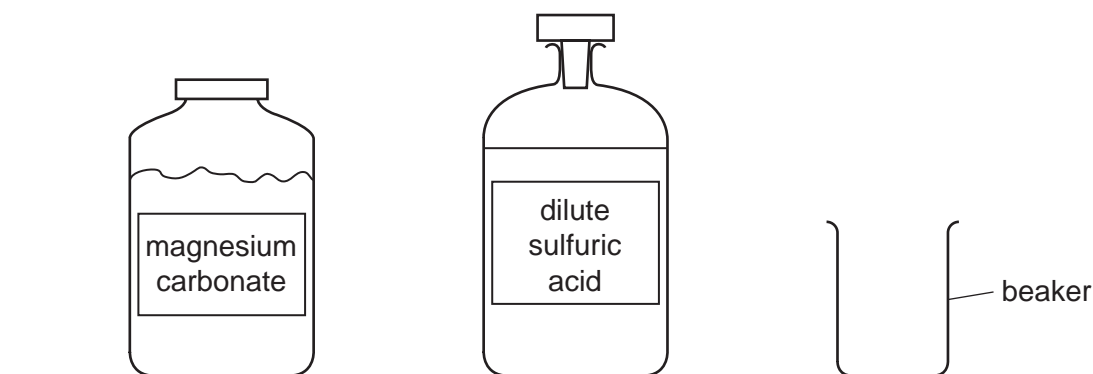

Fig. 5.1

- (a) (i) He places 100 cm^3 dilute sulfuric acid in a beaker and reacts it with magnesium carbonate powder.

Name **two** other pieces of apparatus, not shown in Fig. 5.1, that the student will need to carry out this experiment.

1

2 [2]

- (ii) The reaction takes place at room temperature. Magnesium carbonate is insoluble in water.

The equation for the reaction is shown below.

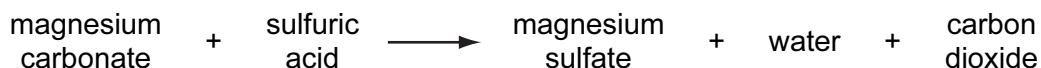

Suggest **two** observations that will tell the student when he has added enough magnesium carbonate to react with all the sulfuric acid.

1

2 [2]

(b) When the reaction has finished, the magnesium carbonate is in excess in the mixture.

Draw a labelled diagram to show how the excess magnesium carbonate can be separated from the mixture.

For
Examiner's
Use

[2]

(c) (i) The student wishes to make crystals of magnesium sulfate from the magnesium sulfate solution.

Explain how he can do this.

.....
.....
.....
.....
..... [3]

(ii) The student has made some small crystals of magnesium sulfate.

Explain how he can grow one large crystal of this substance.

.....
.....
..... [1]

- 6 A student is using a ray box which emits two parallel beams of light. The student is investigating how a mirror, a lens and a glass block will affect the direction of the beams.

For
Examiner's
Use

Experiment 1

The ray box is placed so that the beams meet a mirror at an angle, shown in Fig. 6.1. The rays are reflected on to a screen.

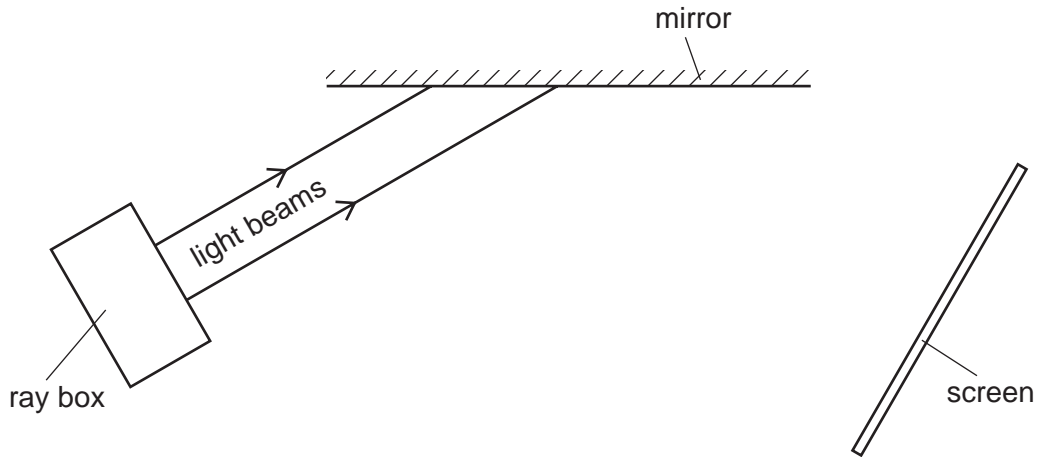

Fig. 6.1

- (a) (i) Use a protractor to draw lines on Fig. 6.1 showing the paths of the reflected beams from the mirror to the screen. [2]

- (ii) State the law that enables you to draw the rays.

.....
 [1]

Experiment 2

The ray box is placed so that the beams of light pass through a converging lens, Fig. 6.2. A converging lens is thicker in the middle and refracts rays of light so that they bend towards each other.

A focal point, **F**, is marked on the diagram. The beams of light pass through the lens, through the focal point and on to the screen.

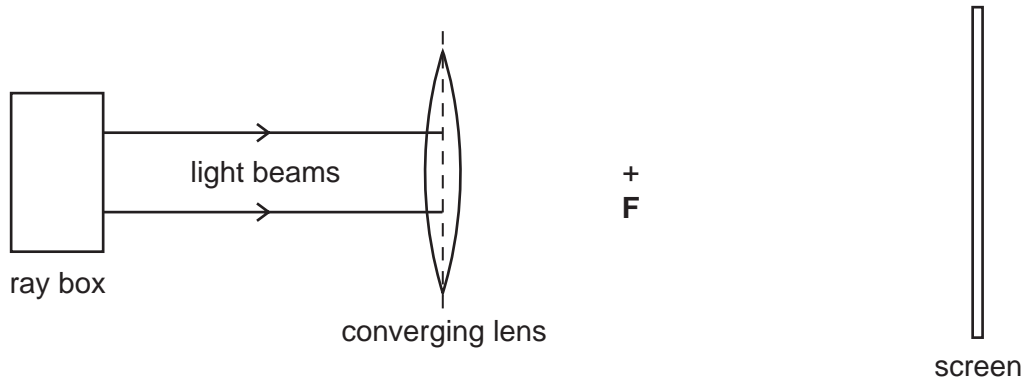
**Fig. 6.2**

- (b) On Fig. 6.2, draw lines to show the paths of the two beams from the lens on to the screen.

Measure, to the nearest 0.1 cm, the distance between the two points where your drawn rays meet the screen.

distance = cm [1]

For
Examiner's
Use

Experiment 3

The ray box is placed so that the rays pass through a parallel-sided glass block and on to the screen on the opposite side. This is shown in Fig. 6.3.

For
Examiner's
Use

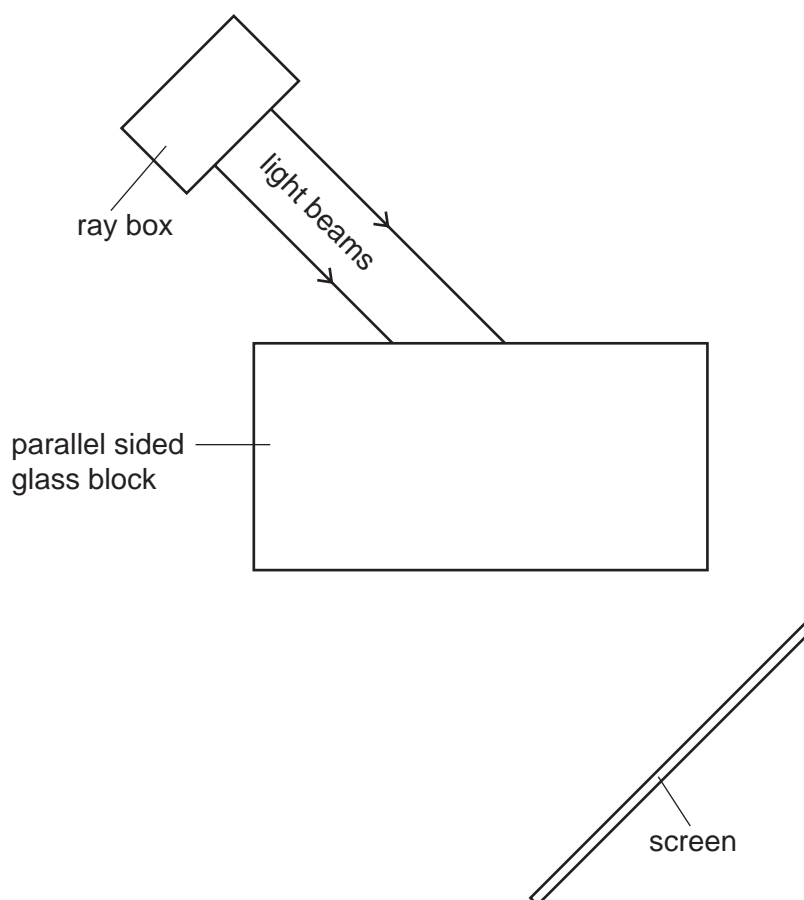

Fig. 6.3

- (c) (i) Use a ruler to draw lines on Fig. 6.3 to show the possible paths of the two beams of light as they pass through the glass block and on to the screen.

Draw the lines as accurately as possible. [4]

- (ii) At the point where **one** of the beams enters the block, draw a line at 90° to the edge of the glass block.

Label the angle of incidence and the angle of refraction. [2]