



Cambridge O Level

CANDIDATE
NAME

--

CENTRE
NUMBER

--	--	--	--	--

CANDIDATE
NUMBER

--	--	--	--

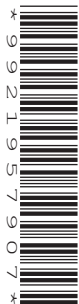

DESIGN & TECHNOLOGY

6043/32

Paper 3 Resistant Materials

October/November 2022

1 hour

You must answer on the question paper.

No additional materials are needed.

INSTRUCTIONS

- Section A: answer **all** questions.
- Section B: answer **one** question.
- Use a black or dark blue pen. You may use an HB pencil for any diagrams or graphs.
- Write your name, centre number and candidate number in the boxes at the top of the page.
- Answer in the space provided.
- Do **not** use an erasable pen or correction fluid.
- Do **not** write on any bar codes.
- You may use a calculator.

INFORMATION

- The total mark for this paper is 50.
- The number of marks for each question or part question is shown in brackets [].
- All dimensions are in millimetres.

This document has **20** pages.

Section A

Answer **all** questions in this section.

1 Fig. 1.1 shows a set of steps used in a swimming pool.

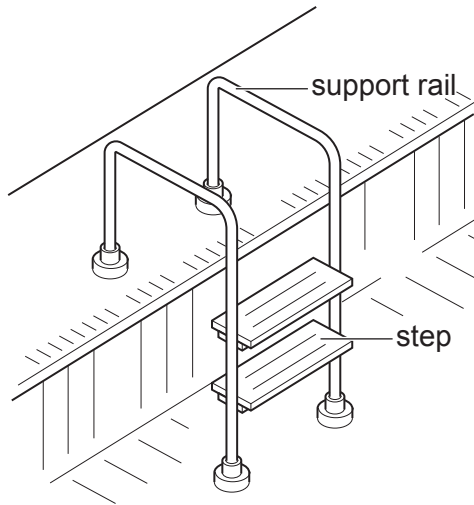

Fig. 1.1

Give the name of:

(a) a suitable specific metal that could be used to make the support rails

..... [1]

(b) a specific plastic for the steps.

..... [1]

2 Fig. 2.1 shows part of a manufactured board. The board will be covered with a veneer.

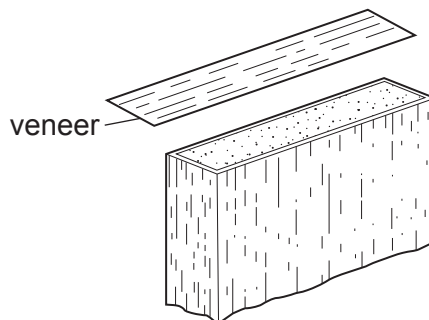

Fig. 2.1

(a) Give **one** benefit of using a contact adhesive to join the veneer to the manufactured board.

..... [1]

(b) Give **one** drawback of using a contact adhesive to join the veneer to the manufactured board.

..... [1]

3 Fig. 3.1 shows a card model of an adjustable lamp mechanism.

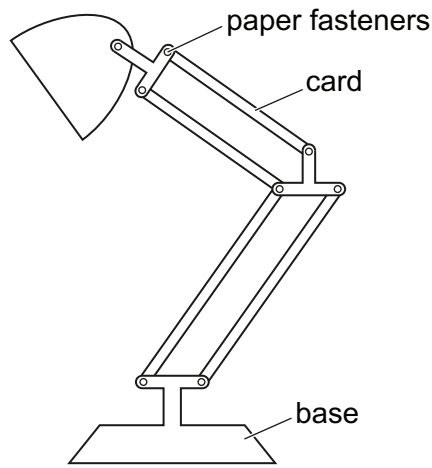

Fig. 3.1

Give **two** benefits of making a card model when designing the adjustable lamp mechanism.

1

2

[2]

4 A list of materials is given below.

ABS aluminium polypropylene brass mild steel melamine formaldehyde

Select, from the list, **one** material that is a:

(a) ferrous alloy

(b) non-ferrous alloy

(c) thermosetting plastic

[3]

5 Fig. 5.1 shows an electronic digital micrometer.

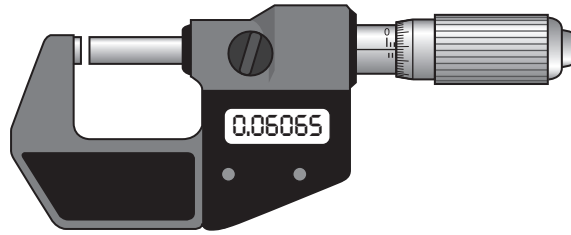

Fig. 5.1

Describe **one** specific use for the electronic digital micrometer.

.....
..... [2]

6 Fig. 6.1 shows a battery that has been 'blister packaged'.

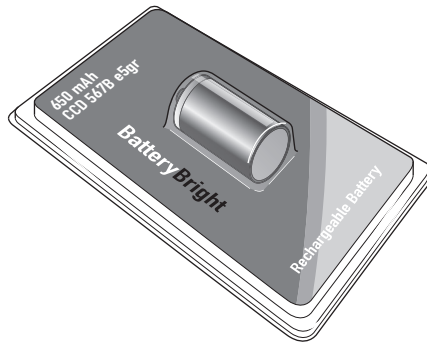

Fig. 6.1

(a) State **two** benefits of blister packaging products.

1
2 [2]

(b) Describe **one** environmental problem caused by blister packaging.

.....
..... [2]

7 Fig. 7.1 shows two pieces of hardwood that will be joined by means of a dowel joint.

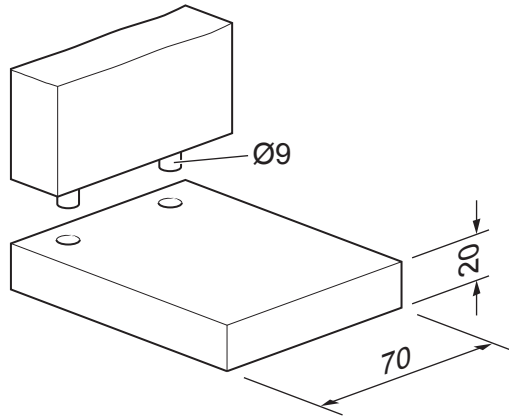

Fig. 7.1

Use sketches and notes to show a design for a jig that would allow the holes to be drilled accurately in both pieces of hardwood.

[3]

8 Fig. 8.1 shows a length of 20 × 20 square tube and a length of Ø10 rod.

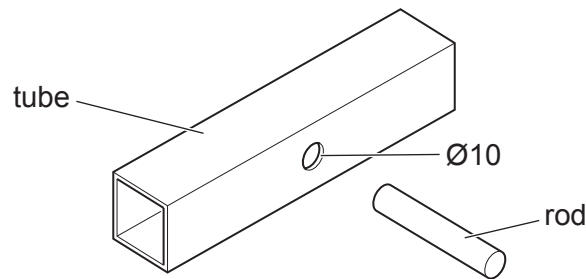

Fig. 8.1

State a method of joining the rod to the tube permanently when they were both made from:

brass

mild steel

acrylic

[3]

9 Fig. 9.1 shows a wooden drawer and the top of a desk.

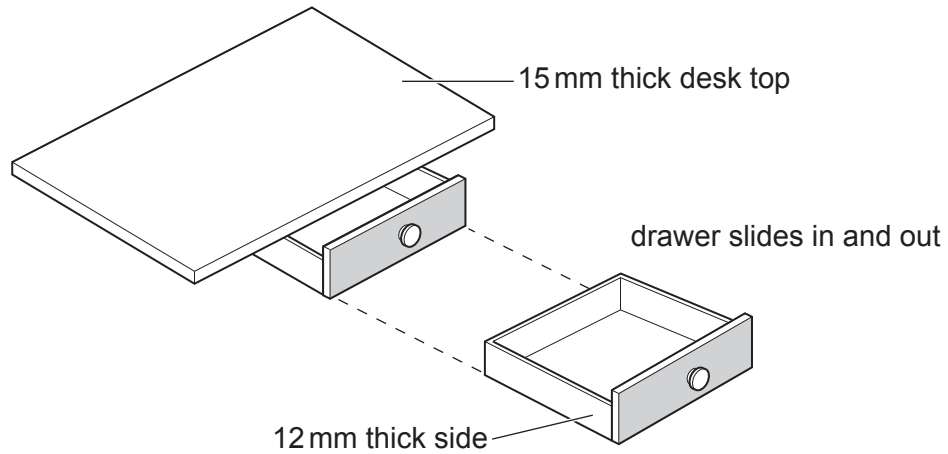

Fig. 9.1

Use sketches and notes to show how the drawer could be supported under the desk top and allowed to slide in and out. Show all constructional details.

[3]

10 A list of energy resources is given below.

coal

natural gas

geothermal

crude oil

Circle, from the list, the energy resource that is renewable.

[1]

Section B

Answer **one** question from this section.

- 11 Fig. 11.1 shows a small table made from hardwood.
The table top has been removed to show details of the legs and rails.

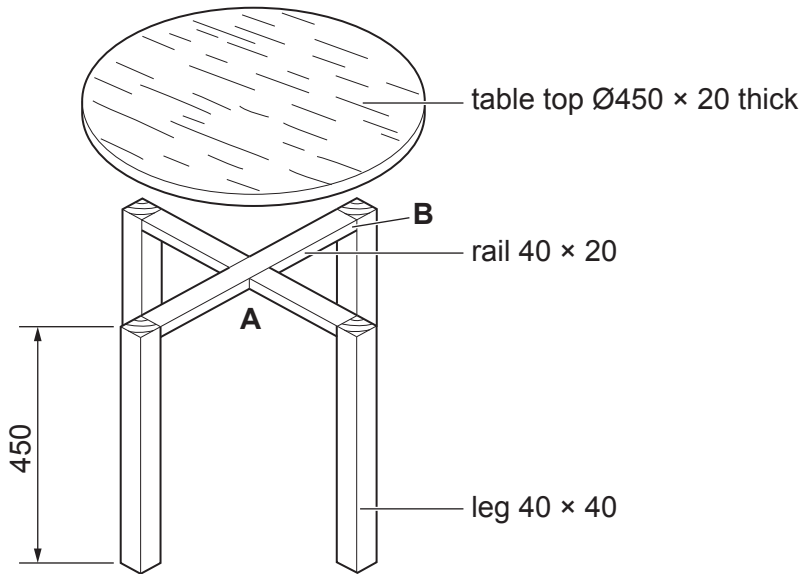
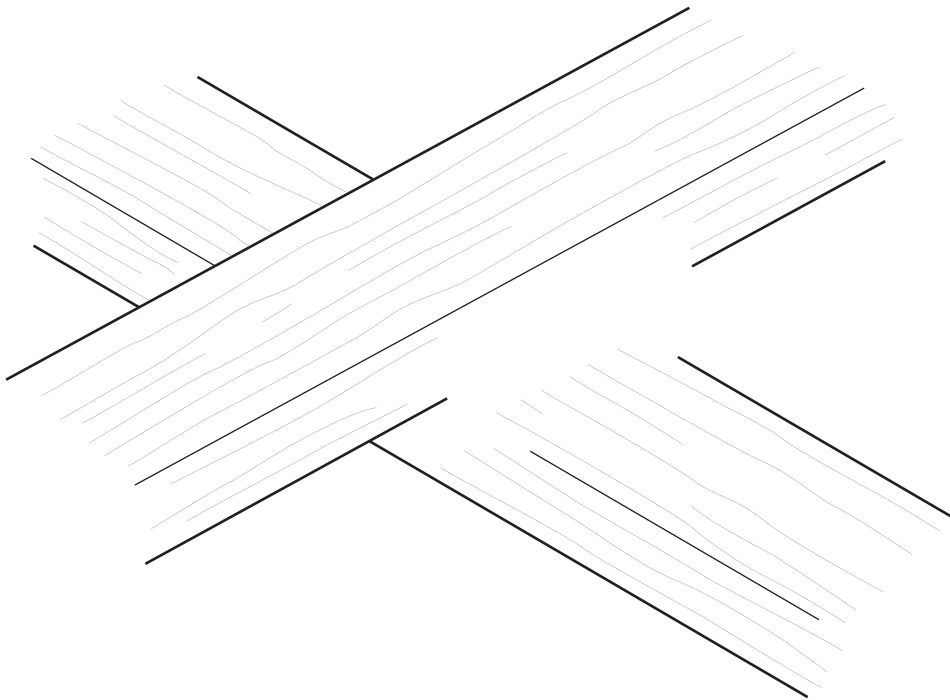

Fig. 11.1

- (a) The rails are joined at **A** by means of a cross-halving joint.
Complete the exploded drawing below to show a cross-halving joint.



[3]

(b) Sketch and name a permanent method of joining the rail to the leg shown at **B** in Fig. 11.1.

Name of joint

[4]

(c) The table top will be produced using a woodturning lathe.

Fig. 11.2 shows the shape of the table top marked out on a hardwood board.

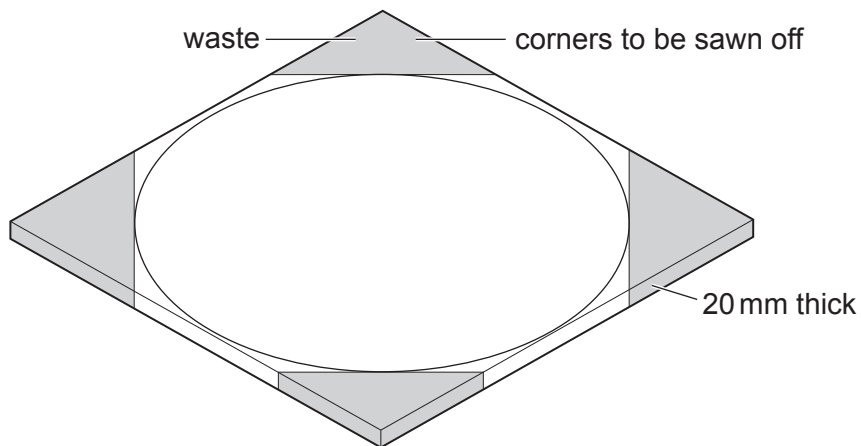

Fig. 11.2

(i) Name **two** machine saws that could be used to remove the waste wood shown in Fig. 11.2.

1

2

[2]

(ii) Circle, from the list below, the method of woodturning that would be used to produce the table top.

taper

parallel

faceplate

between-centres

[1]

(iii) State **two** checks that would need to be carried out after setting up the hardwood board on the woodturning lathe.

1

2

[2]

(d) The palm sander shown in Fig. 11.3 could be used to prepare the parts of the table to take a clear finish.

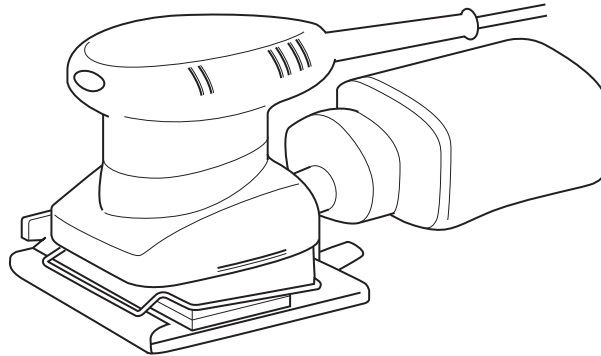

Fig. 11.3

(i) State **two** advantages of using a palm sander to prepare the parts of the table rather than by hand using a cork block and glasspaper.

1

2

[2]

(ii) Explain why a clear finish rather than an opaque finish would be applied to the parts of the table.

.....

.....

..... [2]

(iii) Name **two** suitable clear finishes that could be applied to the parts of the table.

1

2

[2]

- (e) Solid wood contains moisture. Moisture loss can cause the wood to shrink and split. Fig. 11.4 shows the direction in which the hardwood table top could shrink.

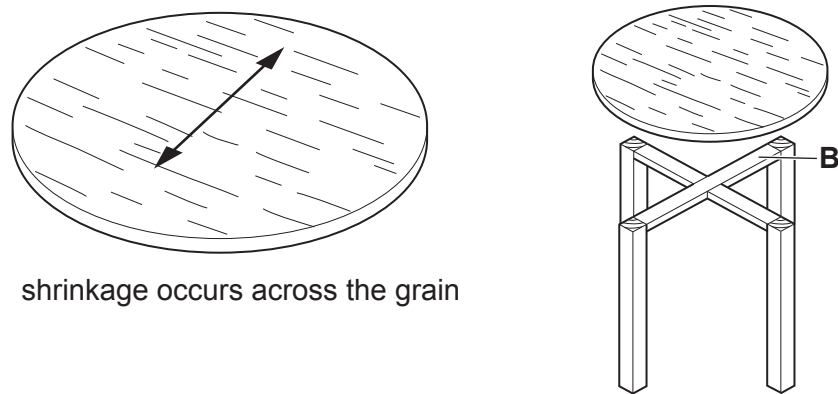
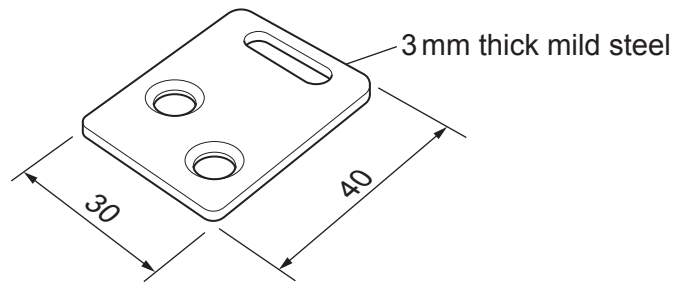

Fig. 11.4

Use sketches and notes to show how the shrinkage plate shown below could be used to fasten the table top to rail **B** in such a way to prevent the hardwood from splitting.



[3]

- (f) Fig. 11.5 shows details of a shelf that is to be fitted to the legs of the table at the height shown.

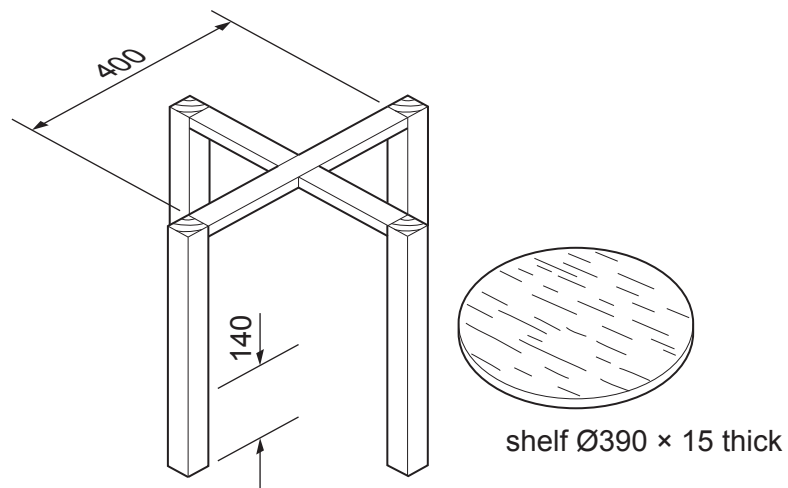

Fig. 11.5

Use sketches and notes to show how the shelf could be joined to the legs **without** the use of additional rails. Show all the constructions and any fittings used.

[4]

- 12 Fig. 12.1 shows a book stand that will be used to display books in a school library. The book stand is made from 5 mm thick acrylic and a batch of ten will be produced by hand in a school workshop.

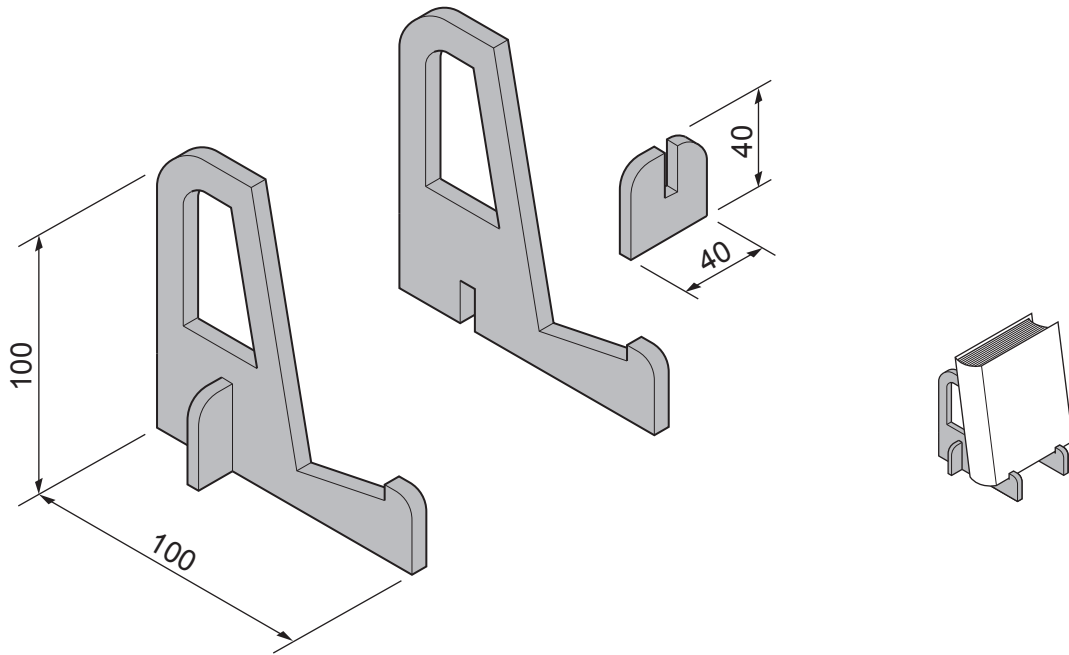

Fig. 12.1

- (a) Fig. 12.2 shows two templates that will be used to mark out the shapes onto acrylic sheet.

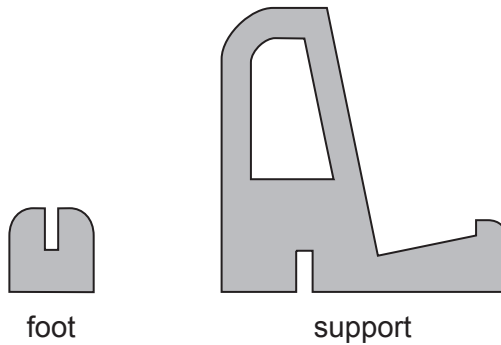

Fig. 12.2

- (i) Give **one** reason why a template made from card would not be suitable when making a large batch of products.

..... [1]

- (ii) Name **two** different tools or items of equipment that could be used to draw around the templates to mark the surface of the acrylic sheet.

1

2

[2]

(b) Fig. 12.3 shows one support marked out on a sheet of acrylic.

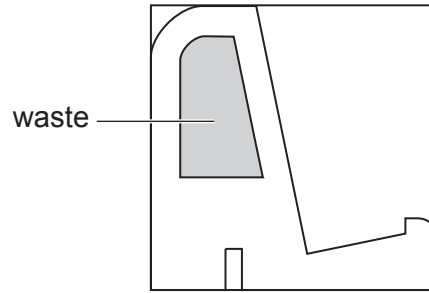

Fig. 12.3

Use sketches and notes to show how the waste material shown in Fig. 12.3 could be removed. Name all the tools and equipment used. Do **not** include any filing of the edges.

[3]

(c) Fig. 12.4 shows one support after all the waste has been removed.

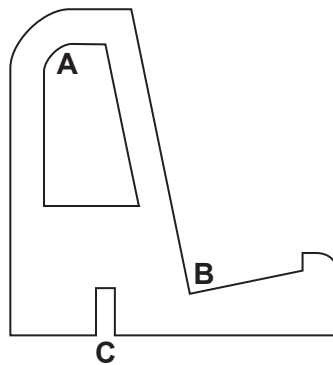

Fig. 12.4

Name **three** different types of file that could be used when filing the parts of the support.

Curve **A**

Corner **B**

Slot **C**

[3]

- (d) Twenty supports and twenty feet will be required to batch produce ten complete book stands. Use sketches and notes to show **one** method, other than by using templates, of ensuring that all **twenty** supports are made to an identical size and shape.

[2]

- (e) Fig. 12.5 shows a different design for a book stand made from one length of $\text{Ø}5$ non-ferrous metal rod.

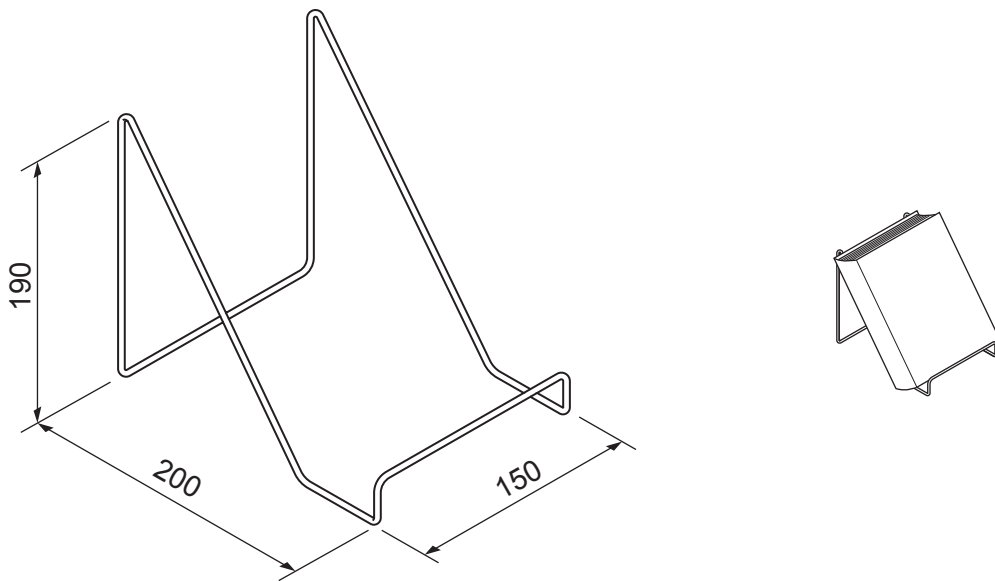

Fig. 12.5

- (i) Name a suitable non-ferrous metal for the book stand.

..... [1]

- (ii) The non-ferrous metal used to make the book stand must be able to be bent to shape easily.

Circle, from the list below, the term that describes the ability of a metal to be shaped without breaking.

flexibility **hardness** **malleability** **toughness** [1]

(iii) Use sketches and notes to show how a single length of Ø5 non-ferrous metal rod could be bent to the shape of the book stand shown in Fig. 12.5.
Name all the tools and equipment used.

[5]

(iv) When hammering the metal into shape it can become 'work hardened'.
Name the process used to make the metal softer so that it can continue to be shaped without breaking.

..... [1]

(v) The Ø5 rod will have a clear lacquer finish.
Give **two** benefits of a clear lacquer finish for the non-ferrous metal book stand.

1

2

[2]

(f) Describe **one** different design feature of each of the book stands shown in Fig. 12.1 and Fig. 12.5.

Acrylic book stand Fig. 12.1

.....

Metal book stand Fig. 12.5

.....

[4]

13 Fig. 13.1 shows an incomplete design for a table football game.

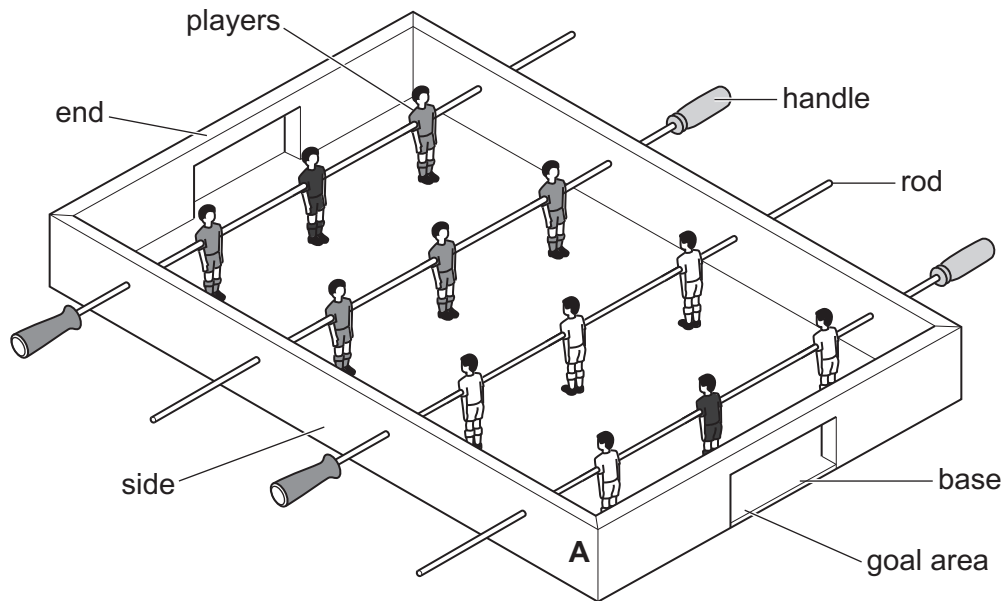

Fig. 13.1

- (a) Table 13.1 shows a parts list for the table football game. Complete Table 13.1 by stating the name of a specific material that could be used for each part of the table football game.

Table 13.1

Part	No.	Length × Width × Thickness	General material	Specific material
Sides	2	480 × 60 × 15	Hardwood	
Ends	2	310 × 60 × 15		
Base	1	480 × 290 × 4	Manufactured board	
Rods	4	490 × Ø8	Non-ferrous metal	
Players	12	80	Plastic	

[4]

(b) Fig. 13.2 shows the corner joint **A**.

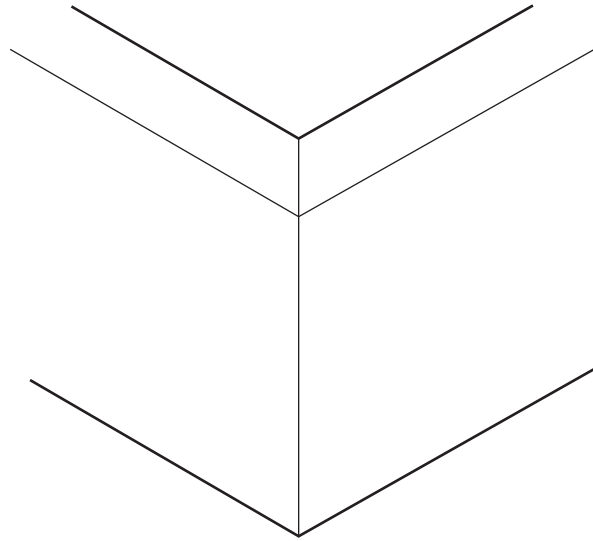

Fig. 13.2

(i) Name the joint shown in Fig. 13.2.

..... [1]

(ii) Add sketches and notes to Fig. 13.2 to show how the joint could be strengthened. [2]

(c) Fig. 13.3 shows a rebate used to join the base and sides of the table football game. A power router will be used to cut out the shape of the rebate.

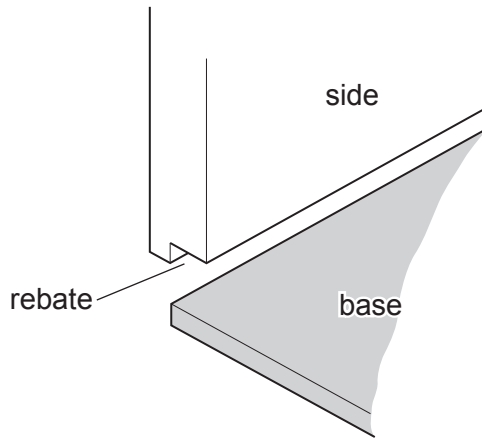

Fig. 13.3

State **two** settings that need to be made before the power router can be used.

1

2

[2]

(d) Fig. 13.4 shows details of one of the goal areas.

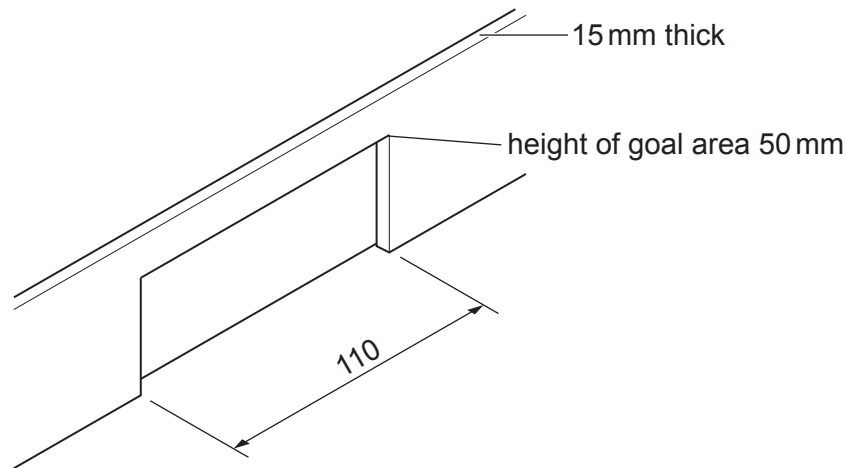

Fig. 13.4

Use sketches and notes to show a method of retaining a ball when a goal is scored. Include details of the materials, fittings and constructions used.

[4]

(e) The players are made from a plastic.

(i) Circle, from the list below, the method of manufacture used to produce the players.

vacuum forming **extrusion moulding** **injection moulding** [1]

(ii) The players could be joined to the non-ferrous rod by means of an adhesive.

Name a suitable adhesive.

..... [1]

- (f) Fig. 13.5 shows part of a scoreboard that could be attached to the sides of the table football game. The slider and scoreboard are made from 3 mm thick acrylic.

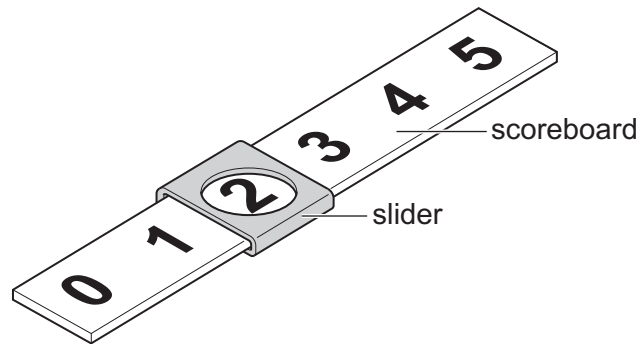

Fig. 13.5

- (i) Fig. 13.6 shows details of the slider used on the scoreboard.

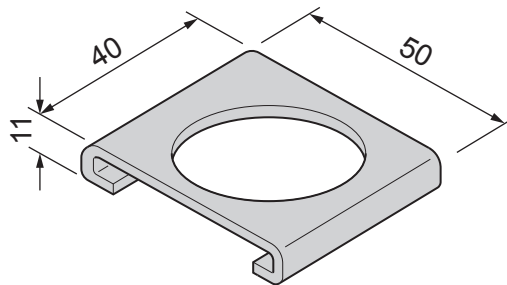
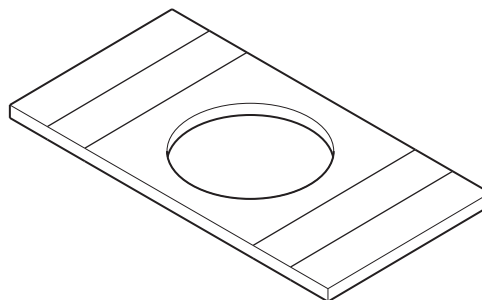

Fig. 13.6

Use sketches and notes to show how the length of marked out acrylic, shown below, could be bent to the shape of the slider.



- (ii) Complete Table 13.2 by stating **three** additional stages when using CAM to produce the numbers on the scoreboard.

Table 13.2

Stage	Process
1	<i>CAD software used to design numbers. File saved.</i>
2	
3	
4	

[3]

- (g) Use sketches and notes to show how the sides of the table football game could be protected when the rods are pushed and pulled by the handles.
Name any materials and fittings used.

[3]

Permission to reproduce items where third-party owned material protected by copyright is included has been sought and cleared where possible. Every reasonable effort has been made by the publisher (UCLES) to trace copyright holders, but if any items requiring clearance have unwittingly been included, the publisher will be pleased to make amends at the earliest possible opportunity.

To avoid the issue of disclosure of answer-related information to candidates, all copyright acknowledgements are reproduced online in the Cambridge Assessment International Education Copyright Acknowledgements Booklet. This is produced for each series of examinations and is freely available to download at www.cambridgeinternational.org after the live examination series.

Cambridge Assessment International Education is part of Cambridge Assessment. Cambridge Assessment is the brand name of the University of Cambridge Local Examinations Syndicate (UCLES), which is a department of the University of Cambridge.